

# Customer Information Sheet

DRAWING No.: M80-740XXXX

SHEET 2 OF 2

IF IN DOUBT - ASK

©

NOT TO SCALE

THIRD ANGLE PROJECTION

ALL DIMENSIONS IN mm

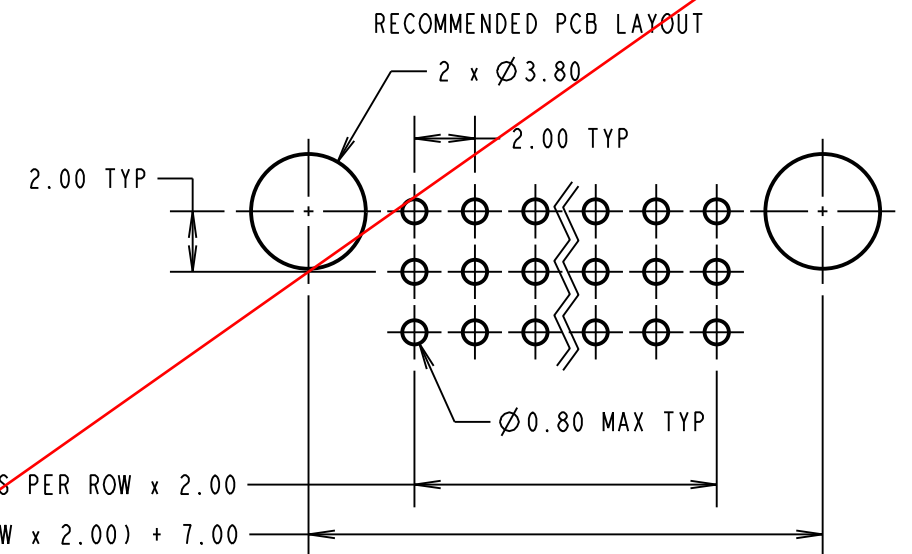
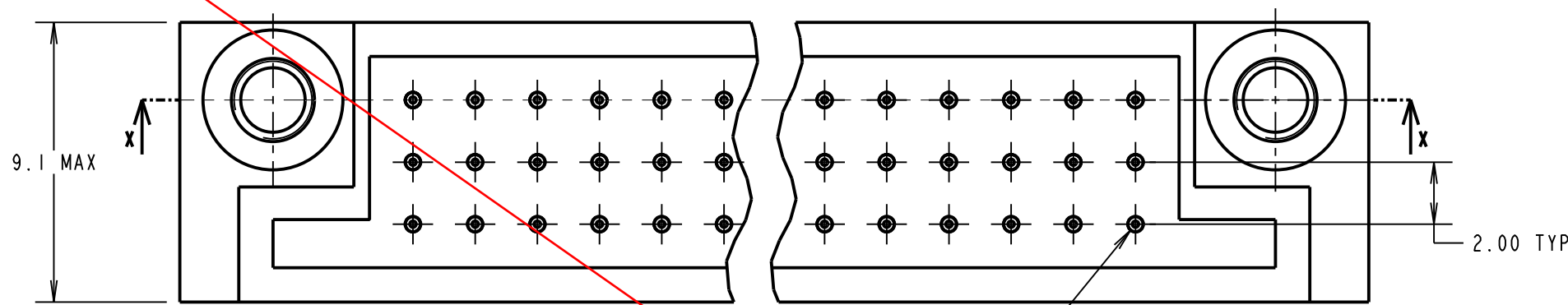

**OBSOLETE**

No. 1 CONTACT  
(SEE NOTE 1)

No. OF PITCHES PER ROW x 2.00  
(No. OF PITCHES PER ROW x 2.00) + 7.00

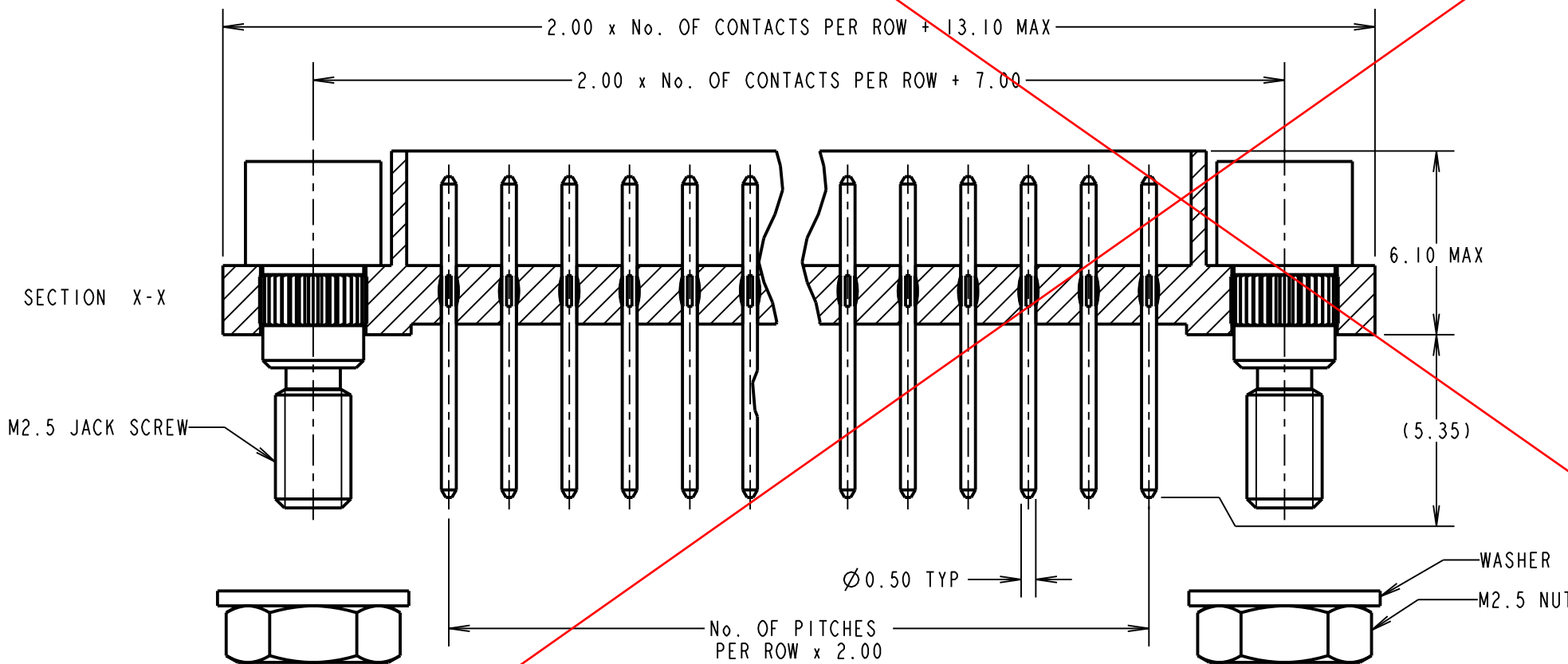

**SPECIFICATION:**  
**MATERIAL:**  
 MOULDING = POLYAMIDE 46 UL94V-0, BLACK  
 CONTACT = PHOSPHOR BRONZE  
 JACKSCREWS = STAINLESS STEEL  
**FINISH:**  
 05 = 0.25-0.3µ GOLD  
 22 = 0.75µ GOLD ON CONTACT AREA, 3.0µ 90/10 TIN/LEAD ON TAILS  
**ELECTRICAL:**  
 CURRENT RATING AT 25°C = 3.0A MAX  
 CURRENT RATING AT 85°C = 2.2A MAX  
 VOLTAGE PROOF = 360V AC/DC  
 CONTACT RESISTANCE (INITIAL) = 20mΩ MAX  
 CONTACT RESISTANCE (AFTER CONDITIONING) = 25mΩ MAX  
 INSULATION RESISTANCE (INITIAL) = 1,000MΩ MIN  
 INSULATION RESISTANCE (AFTER CONDITIONING) = 100MΩ MIN  
**MECHANICAL:**  
 DURABILITY = 500 OPERATIONS  
 MAXIMUM INSERTION FORCE = No. OF CONTACTS x 2.8N  
 MAXIMUM WITHDRAWAL FORCE = No. OF CONTACTS x 1.8N  
 MINIMUM WITHDRAWAL FORCE = No. OF CONTACTS x 0.2N  
**ENVIRONMENTAL:**  
 TEMPERATURE RANGE = -55°C TO +125°C  
**PACKING:**  
 TRAYS  
 FOR COMPLETE SPECIFICATION, SEE COMPONENT SPECIFICATION C017XX (LATEST ISSUE)

**NOTES:**  
 1. FROM No. 1 POSITION, CONTACTS NUMBERED IN SEQUENCE FROM RIGHT TO LEFT AND FROM BOTTOM ROW TO TOP ROW.

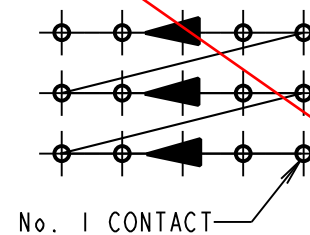

ORDER CODE:  
**M80-740XXXX**  
 TOTAL No. OF CONTACTS:  
 27, 36, 45, 51, 63  
 FINISH:  
 05 = GOLD  
 22 = SELECTIVE GOLD

SM	7	13.07.11	11343
NAME	ISS.	DATE	C/NOTE
APPROVED: S. MCCULLAGH			
CHECKED: M. G. PLESTED			
DRAWN: A. LIOTTA			
CUSTOMER REF.:			
ASSEMBLY DRG:			

<b>HARWIN</b>			THIS DRAWING AND ANY INFORMATION OR DESCRIPTIVE MATTER SET OUT HEREON ARE CONFIDENTIAL AND COPYRIGHT PROPERTY OF THE HARWIN GROUP AND MUST NOT BE DISCLOSED, LOANED, COPIED OR USED FOR MANUFACTURING, TENDERING OR FOR ANY OTHER PURPOSE WITHOUT THEIR WRITTEN PERMISSION.	TOLERANCES X. = ±1mm X.X = ±0.25mm X.XX = ±0.10mm X.XXX = ±0.01mm ANGLES = ±5° UNLESS STATED	MATERIAL: SEE ABOVE FINISH: SEE TABLE S/AREA: mm <sup>2</sup>	TITLE: JACKSCREW DATAMATE 3-ROW MALE VERTICAL PC TAIL ASSEMBLY DRAWING NUMBER: <b>M80-740XXXX</b>	SHT 2 OF 2
HARWIN USA TEL: 603 893 5376 FAX: 603 893 5396 mis@harwin.com	HARWIN Europe (UK) TEL: 023 9231 4545 FAX: 023 9231 4590 mis@harwin.co.uk	HARWIN Asia TEL: +65 6 779 4909 FAX: +65 6 779 3868 mis@harwin.com.sg		HARWIN USA TEL: 603 893 5376 FAX: 603 893 5396 mis@harwin.com			