

PART NAME: KNOB SCALE: 1:1 DATE: 11/4/63 DR. BY LS

THIS DRAWING IS THE PROPERTY OF DAVIES MOLDING COMPANY, IS SUBMITTED SOLELY AS A DESIGN OR ENGINEERING PROJECT. WE ACCEPT NO RESPONSIBILITY WHATSOEVER FOR THE PRACTICAL APPLICATION OF THE PIECES MADE TO THIS DESIGN.



DESIGNERS & MANUFACTURERS OF KNOBS, HANDLES, CASES & CUSTOM PLASTIC COMPONENTS

P/N	2965FC
M NO.	2965
CAVITY	2965
PLUNGER	2965
CHASE	2965
PIN BAR	2965-AR
SHIM	# 6
INSERT	I0553

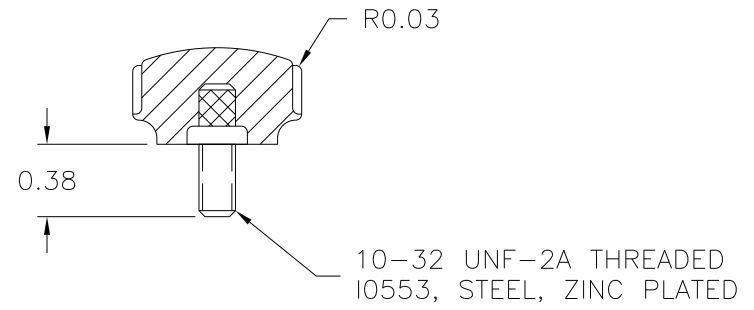
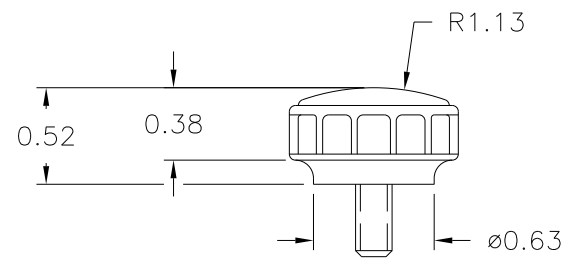
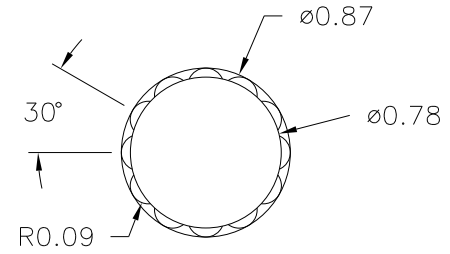

(A)
 MATERIAL: 04311 PHENOLIC (B41)
 COLOR: BLACK

TOLERANCES: UNLESS OTHERWISE SPECIFIED	DO NOT SCALE DRAWING	A	WAS #2511 PHENOLIC (B11)	JAM	7/2/08
DECIMALS: X.XXX ± .005 X.XX ± .015	MM: X.XX ± 0.15MM X.X ± 0.4MM	-	RE-DID REDRAW	TL	11/23/99
FRACTIONS ± 1/64	ANG. ± 1°	-	CAD REDRAW	HD	8/13/97
CHANGES					