

THIS DRAWING IS UNPUBLISHED. RELEASED FOR PUBLICATION
 © COPYRIGHT 19 BY AMP INCORPORATED. ALL INTERNATIONAL RIGHTS RESERVED.

LOC		DIST		P		F		REVISIONS			
ZONE	LTR	DESCRIPTION	DATE	APPD							
G	14					G	REL PER 0G3A-0075-01	28JAN01	JR/MS		

METRIC
 DIMENSIONS LISTED IN mm [INCHES]

AMP WIRE RANGE	UL E13288 Listed
12-10 AWG SOLID OR STRANDED	12-10 AWG STRANDED PN 36270 ONLY
CS LR7189 Certified	MILITARY P/N AND CLASS
12-10 AWG SOLID OR STRANDED PN 36270 ONLY	NOT APPLICABLE

△ STAMP AMP 12-10* APPROX AS SHOWN

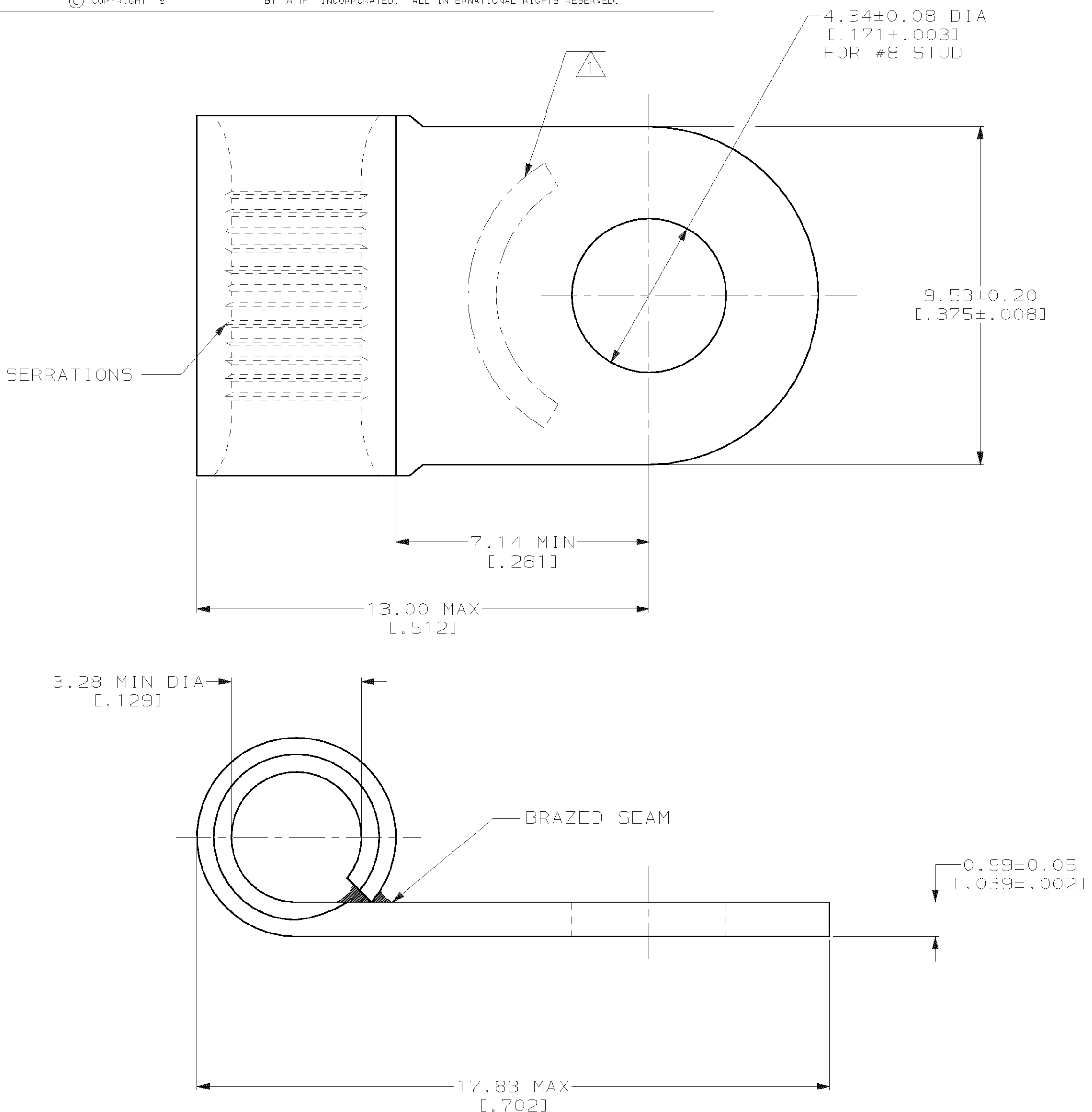

343°C	NICKEL PLATE 0.00762[.000300] MIN THK PER QQ-N-290	1-36270-1
170°C	TIN PLATE 0.00254[.000100] MIN THK PER ASTM B 545	36270
MAX OPERATING TEMPERATURE	FINISH	PART NO

AMP INCORPORATED
CUSTOMER SERVICE SYSTEMS

FOR ADDITIONAL PRODUCT INFORMATION OR COPIES OF DRAWINGS AND TECHNICAL DOCUMENTS	PRODUCT INFORMATION CENTER 1-800-522-6752
FOR APPLICATION TOOLING INFORMATION	TOOLING ASSISTANCE CENTER 1-800-722-1111
FOR ORDER ENTRY	1-800-526-5142

MAX RECOMMENDED OPERATING TEMPERATURE:
SEE TABLE

VOLTAGE RATING:
NOT APPLICABLE

WIRE CROSS SECTIONAL AREA RANGE:
2.62-6.64mm² [5,180-13,100] CIR MILS
SOLID OR STRANDED

THIS DRAWING IS A CONTROLLED DOCUMENT FOR AMP INCORPORATED. IT IS SUBJECT TO CHANGE AND THE CONTROLLING ENGINEERING ORGANIZATION SHOULD BE CONTACTED FOR THE LATEST REVISION.

DO NOT SCALE PRINT. UNLESS SPECIFIED DIMENSIONS IN mm [INCHES]— TOLERANCES ON :
 2 PLC DEC ± -
 3 PLC DEC ± -
 ANGLES ± -

MATERIAL
COPPER PER ASTM B-152 ANNEALED

FINISH
SEE TABLE

DR 4-5-93
TA BRINKMAN

CHK 4-5-93
DA PATTERSON

APPD 4-5-93
DE MILLER

APPD 4-5-93
JL MECKLEY

PRODUCT SPEC
-

APPLICATION SPEC
-

WEIGHT
-

AMP AMP Incorporated
 Harrisburg, PA 17105-3608

NAME
TERMINAL, RING TONGUE, FLAG, SOLISTRAND™

SIZE **C** CAGE CODE **00779** DRAWING NO **C-36270**

SCALE 10:1 SHEET 1 OF 1