

PART NUMBER	REVISION	DESCRIPTION	FEED TYPE
2151164-1	M	FINE CRIMP HEIGHT ADJUST	MECHANICAL
2151164-2	M	FINE CRIMP HEIGHT ADJUST	PNEUMATIC
5-2151164-1	M	SEAL STRIPPER CRIMPER TERMINATING UNIT	MECHANICAL
5-2151164-2	M	SEAL STRIPPER CRIMPER TERMINATING UNIT	PNEUMATIC
7-2151164-1	M	MECHANICAL AND CRIMP TOOLING KIT	MECHANICAL
7-2151164-2	M	PNEUMATIC AND CRIMP TOOLING KIT	PNEUMATIC
7-2151164-7	F	CRIMP TOOLING KIT	-

ATLANTIC VERSION TERMINATOR INTERFACE ADAPTER

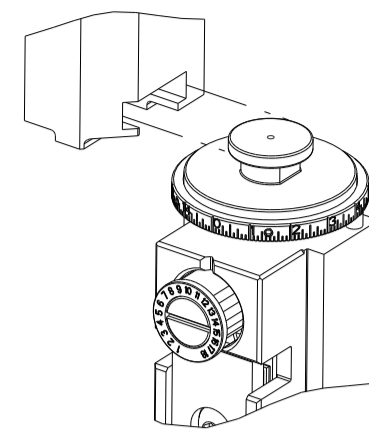

APPLICATOR DATA		
CRIMP	SIZE	TYPE
WIRE	2.03 mm [.080]	F
INSUL	2.54 mm [.100]	OV

APPLICATOR INSTRUCTIONS 408-35042

TERMINAL DATA: TE TERMINAL		TE CRIMP SPECIFICATION	
TERMINAL NAME: 2.8MM SENSOR - FLAT TYPE RECEPTACLE			
WIRE STRIP LENGTH		INSULATION DIAMETER RANGE	
4.00-4.60 mm [.157-.181 IN]		Ø1.30-2.10 mm [.051-.083 IN]	
TERMINAL APPLICATION SPECIFICATION	(A)114-18144-0		
TERMINALS APPLIED			
TE TERMINAL	TE TERMINAL	TE TERMINAL	TE TERMINAL
967702-1	967702-2	-	-

TERMINAL DATA: TE TERMINAL		TE CRIMP SPECIFICATION	
TERMINAL NAME: 2.8MM SENSOR - FLAT TYPE RECEPTACLE			
WIRE STRIP LENGTH		INSULATION DIAMETER RANGE	
4.00-4.60 mm [.157-.181 IN]		Ø1.30-2.10 mm [.051-.083 IN]	
TERMINAL APPLICATION SPECIFICATION	114-18148		
TERMINALS APPLIED			
TE TERMINAL	TE TERMINAL	TE TERMINAL	TE TERMINAL
1-968849-3	1-968849-1	1-968849-2	1-1355833-1

WIRE SIZE	CRIMP HEIGHT mm [INCH]	CRIMP HEIGHT REFERENCE SETTING
1.00mm2	1.20+/-0.05 [.047+/- .002]	6.5
0.75mm2	1.18+/-0.05 [.046+/- .002]	6.5
0.50mm2	1.15+/-0.05 [.045+/- .002]	7.0

WIRE SIZE	CRIMP HEIGHT mm [INCH]	CRIMP HEIGHT REFERENCE SETTING
0.85mm2 CAVS	1.26+/-0.03 [.050+/- .001]	6.0
0.85mm2 AVS	1.24+/-0.03 [.049+/- .001]	6.2
0.75mm2 AESSX-F	1.23+/-0.03 [.048+/- .001]	6.4
AWG 18	1.23+/-0.03 [.048+/- .001]	6.5
1.00mm2	1.20+/-0.05 [.047+/- .002]	6.5
2x 0.50mm2	1.20+/-0.05 [.047+/- .002]	6.5
0.75mm2	1.18+/-0.05 [.046+/- .002]	6.7
0.50mm2	1.15+/-0.05 [.045+/- .002]	7.0
0.50mm2	1.14+/-0.03 [.045+/- .001]	7.1
0.50mm2	1.12+/-0.03 [.044+/- .001]	7.3
AWG 20	1.08+/-0.05 [.043+/- .002]	7.8

- RECOMMENDED SPARE PARTS
- REFER TO SUPPLIED INSTRUCTION SHEET FOR CLEANING, LUBRICATION AND STORAGE OF APPLICATOR.
- APPLY PART NUMBER 1-23419-5 LOCTITE TO THREADS OF ITEM 180. APPLY PART NUMBER 2-23419-6 LOCTITE TO THREADS OF ITEM 242.
- CRIMP HEIGHT REFERENCE SETTING WAS THE SETTING USED WHEN THE APPLICATOR WAS QUALIFIED AT THE FACTORY. ADJUSTMENT MAY BE NECESSARY WHEN RUNNING APPLICATOR IN THE FIELD.
- 5. UNLESS SPECIFIED OTHERWISE TORQUE VALUES SHALL BE USED PER DOCUMENT, 101-35000.
- THIS CRIMP PARAMETER IS PROVIDED TO MEET A CUSTOM AND UNIQUE CUSTOMER REQUIREMENT. IT HAS BEEN EVALUATED AND IS CONDITIONALLY SPECIFIED BY TE CONNECTIVITY. THIS CUSTOMIZED CRIMP PARAMETER IS NOT LISTED AS AN APPROVED APPLICATION WITHIN A TE CONNECTIVITY APPLICATION SPECIFICATION; HOWEVER, IT HAS BEEN VALIDATED ACCORDING TO TE CONNECTIVITY SPECIFICATIONS 109-18079 (TEST GROUP 1) AND 114-18022. **TE CONNECTIVITY EXPRESSLY DISCLAIMS ANY AND ALL WARRANTIES THAT THE PRODUCT WILL PERFORM SIMILARLY TO VALIDATED AND APPROVED APPLICATIONS, AS STATED WITHIN TE CONNECTIVITY APPLICATION SPECIFICATIONS, INCLUDING BUT NOT LIMITED TO IMPLIED WARRANTIES OF MERCHANTABILITY OR FITNESS FOR PARTICULAR PURPOSE.** AS SUCH, IT IS HIGHLY RECOMMENDED THAT THE CUSTOMER PERFORM FURTHER DETAILED EVALUATION TO ASSESS PRODUCT PERFORMANCE IN THE SPECIFIC APPLICATION.
- TERMINAL LUBRICANT IS RECOMMENDED.
- WIRE TYPES AEX-F, AESSX-F, AVS.
- WIRE TYPES AEX, CAVS.

***WARNING**
ON INSTALLATION, SET WIRE DISC TO CRIMP HEIGHT REFERENCE SETTING FOR LARGEST WIRE SIZE. CRIMP HEIGHT REFERENCE SETTINGS GREATER THAN THE VALUE SHOWN MAY CAUSE DAMAGE TO THE CRIMP TOOLING. REFER TO THE INSTRUCTION SHEET FOR PROPER SETUP AND ADJUSTMENTS.

ATLANTIC VERSION
Shown on sheets 1 of 4 & 2 of 4
(Pacific version shown on sheets 3 of 4 & 4 of 4)

LOC	DIST	REVISIONS					
A	66	P	LTN	DESCRIPTION	DATE	OWN	APVD
		L		ECR-19-009410	15JUN2019	TB	TE
		L1		ECR-21-000028	26JAN2021	FJ	RR
		M		ECR-22-128107	30JAN2022	FJ	GB
		M1		ECR-22-157958	10NOV2022	FZ	GB

-	-	-	1	1	-	-	1803515-3	RAM ASSEMBLY, SF ATLANTIC	293
-	-	-	1	1	-	-	2-1803583-1	APPLICATOR BASIC ASSEMBLY, SF	292
-	1	-	1	-	1	-	2119641-1	FEED CAM, AIR FEED	248
-	1	1	1	1	1	1	2119082-8	CAM, SNAIL, INSULATION ADJUSTMENT	244
-	1	1	1	1	1	1	2079764-1	WASHER, WAVE SPRING, CREST-TO-CREST	243
-	1	1	1	1	1	1	2119083-1	RETAINER, INSULATION DIAL	242
-	1	1	1	1	1	1	7-18023-7	SCR, SKT HD CAP M3 X 4.0	241
-	-	1	-	1	-	1	2119580-1	MECHANICAL FEED ASSEMBLY	239
-	1	-	1	-	1	-	2844940-1	AIR FEED MODULE	238
-	-	-	1	1	-	-	4-1722335-3	STRIPPER, SIDE FEED	182
-	-	-	1	1	-	-	1-5018030-0	NUT, HEX, REG, RoHS, M3.5	181
-	-	-	1	1	-	-	1-1752354-9	STANDOFF, HOLD-DOWN	180
-	-	-	1	1	-	-	993111-1	PIN, SLOTTED SPRING 3.0 X 20.0	177
-	-	-	1	1	-	-	5-22280-0	SPRING, COMPRESSION	176
-	-	-	1	1	-	-	1752353-3	GUIDE PIN, HOLDDOWN	175
-	-	-	1	1	-	-	1901680-2	GUIDE PIN, HOLDDOWN	174
-	REF	REF	REF	REF	REF	REF	994970-2	COUNTER, MAGNETIC	164
-	1	1	1	1	1	1	2119955-1	ASSY, LUBRICATOR, SIDE FEED	113
-	1	1	1	1	1	1	2844908-1	SCREW, LOCKING	99
-	1	1	1	1	1	1	2844907-1	POST, LOCKING	98
-	1	1	1	1	1	1	455888-5	SPACER, CRIMPER	82
-	1	1	1	1	1	1	1803607-3	DOCUMENTATION PACKAGE	71
-	1	1	1	1	1	1	2119791-9	DEPRESSOR, WIRE	70
-	1	1	1	1	1	1	2119740-1	TAG, IDENTIFICATION	67
-	2	2	2	2	2	2	2168078-1	SCREW, DRIVE, RH, RoHS, 2 x .188	66
-	1	1	1	1	1	1	2168083-2	SCR, SKT HD CAP, RoHS, M4 X 8.0	60
-	1	1	1	1	1	1	5-18022-5	SCR, HEX HD CAP, M4 X 6.0	59
-	1	1	1	1	1	1	1338685-1	PAWL, FEED	56
-	4	4	4	4	4	4	2168083-3	SCR, SKT HD CAP, RoHS, M4 X 12.0	54
-	2	2	2	2	2	2	1-2168083-0	SCR, SKT HD CAP, RoHS, M4 X 10	53
-	1	1	1	1	1	1	1803382-2	HOLD DOWN, SPRING LOADED	50
-	1	2	1	2	1	2	18023-9	SCR, SKT HD CAP M4 X 6.0	49
-	-	1	-	1	-	1	2119652-1	FEED CAM, PRE FEED	48
-	-	1	-	1	-	1	2119653-1	FEED CAM, POST FEED	47
-	1	1	-	-	1	1	1803583-9	APPLICATOR BASIC ASSEMBLY, SF	46
-	1	1	-	-	1	1	1803515-1	RAM ASSEMBLY, SF ATLANTIC	44
-	1	1	1	1	1	1	1803602-1	SCR, BHSC, RoHS (M8 X 25)	41
-	1	1	1	1	1	1	1-1752356-6	SUPPORT, TERMINAL	34
-	2	2	2	2	2	2	2079383-5	SCR, BHSC, RoHS (M4 X 20)	33
-	2	2	2	2	2	2	2-2844962-8	SPACER, CYLINDRICAL, STRIP GUIDE	30
-	1	1	1	1	1	1	2844992-2	ASSEMBLY, STRIP GUIDE	29
-	1	1	1	1	1	1	455888-6	SPACER, CRIMPER	28
-	1	1	1	1	1	1	1320928-2	STRIP GUIDE	24
-	1	1	-	-	1	1	2168083-2	SCR, SKT HD CAP, RoHS, M4 X 8.0	21
-	2	2	1	1	2	2	1-18028-2	WASHER, FLAT, REG M4	20
-	1	1	-	-	1	1	2119533-1	STRIPPER, SIDE FEED	19
-	1	1	1	1	1	1	2119806-1	INSERT, SHEAR	13
-	1	1	1	1	1	1	3-22280-3	SPRING, COMPRESSION	12
-	1	1	1	1	1	1	1-356885-5	STOP, SHEAR	11
-	1	1	1	1	1	1	2119805-1	SHEAR HOLDER, FRONT	10
-	1	1	1	1	1	1	1803095-3	FLOATING SHEAR, FRONT	9
1	2	2	1	1	1	1	1-1333204-7	ANVIL, COMBINATION	8
-	1	1	1	1	1	1	3-240641-4	SPACER	7
-	-	-	-	-	-	-	-	-	6
-	1	1	1	1	1	1	2119757-3	DEPRESSOR, SHEAR	5
-	1	1	1	1	1	1	238011-4	BLOCK, CRIMPER SPACER	4
1	2	2	1	1	1	1	3-1633964-5	CRIMPER, INSULATION OVERLAP PREMIUM	3
-	1	1	1	1	1	1	455888-4	SPACER, CRIMPER	2
1	2	2	1	1	1	1	1-456405-5	CRIMPER, WIRE PREMIUM	1

ITEM NO	PART NO	DESCRIPTION	ITEM NO
-77	-72	-71	-52
-51	-2	-1	
DIMENSIONS:		TOLERANCES UNLESS OTHERWISE SPECIFIED:	
mm	0 PLC ±	1 PLC ±	2 PLC ±
	3 PLC ±	4 PLC ±	ANGLES ±
MATERIAL	FINISH		
OWN C. MOYER 10AUG2012		TE Connectivity Harrisburg, PA 17105-3608	
CHK T. ELBIN 10AUG2012		NAME Ocean Side Feed Applicator	
APVD T. ELBIN 10AUG2012		SIZE CAGE CODE DRAWING NO RESTRICTED TO	
PRODUCT SPEC		A1 00779 C=2151164	
APPLICATION SPEC		WEIGHT	
MATERIAL		SCALE 1:2 SHEET 1 OF 4 REV M1	
Customer Accessible Production Drawing		Customer Accessible Production Drawing	

LOC	DIST	REVISIONS					
		P	LTN	DESCRIPTION	DATE	OWN	APVD
A	66	-	-	SEE SHEET 1	-	-	-

FEED TYPE MECHANICAL

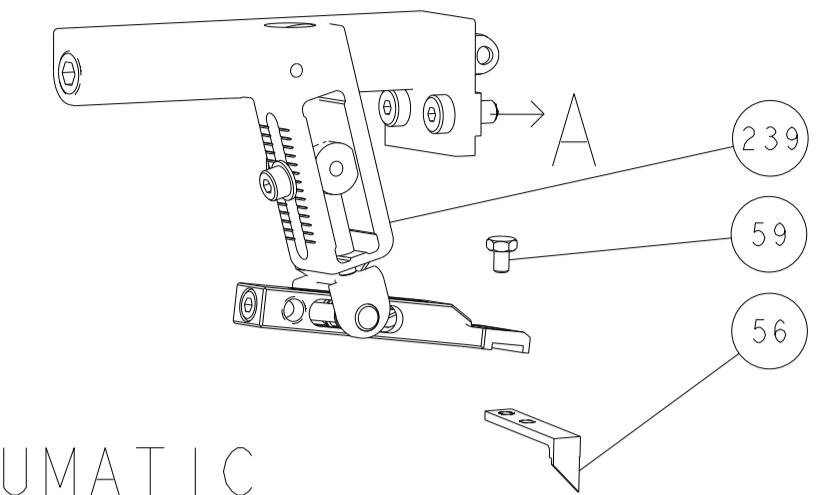

PNEUMATIC

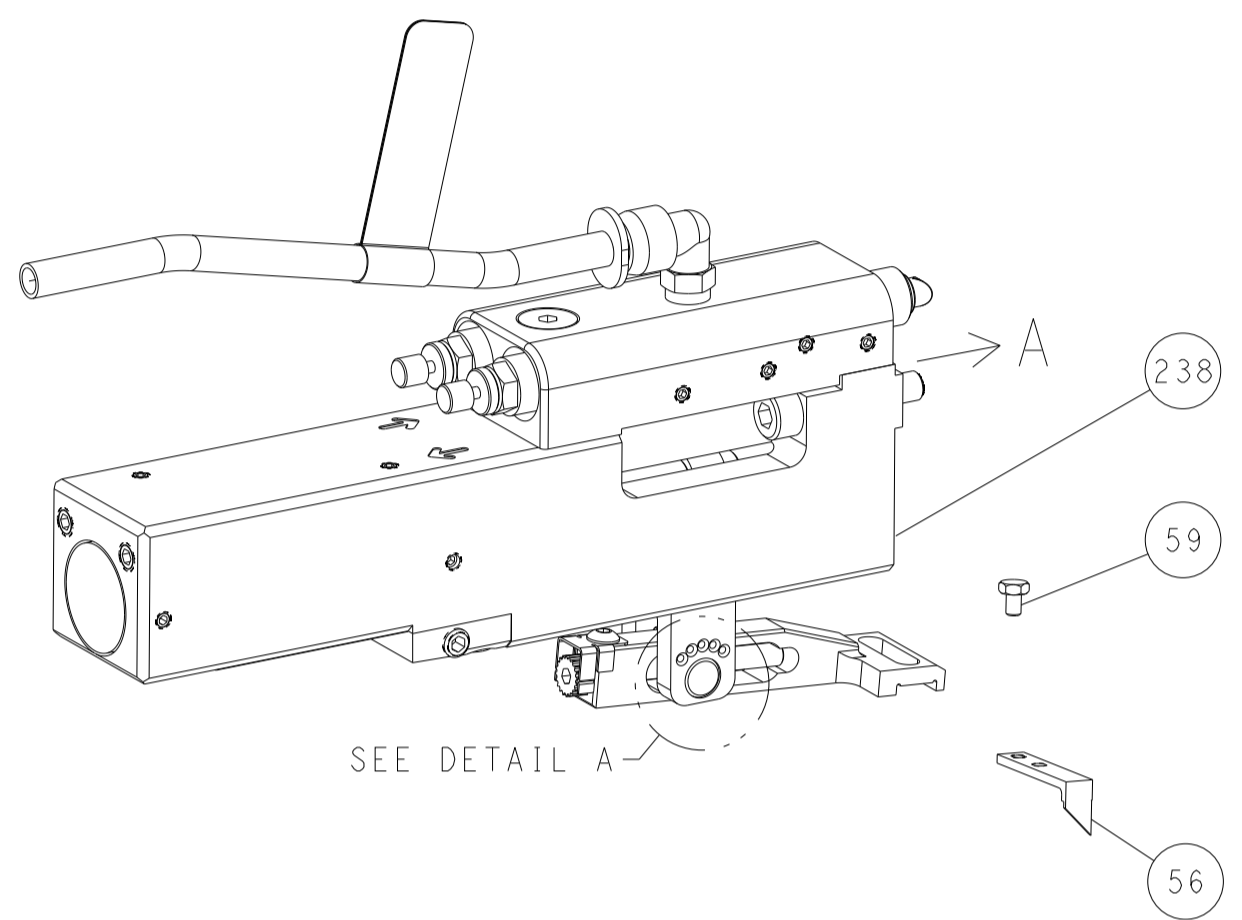

FEED SPRING SETTING POSITION (SHOWN FROM REAR SIDE)

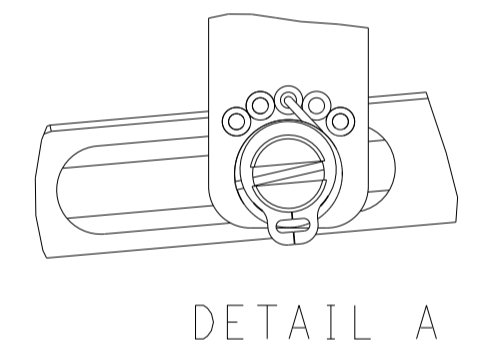

DETAIL A

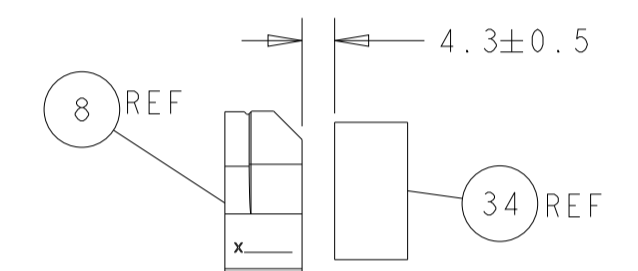
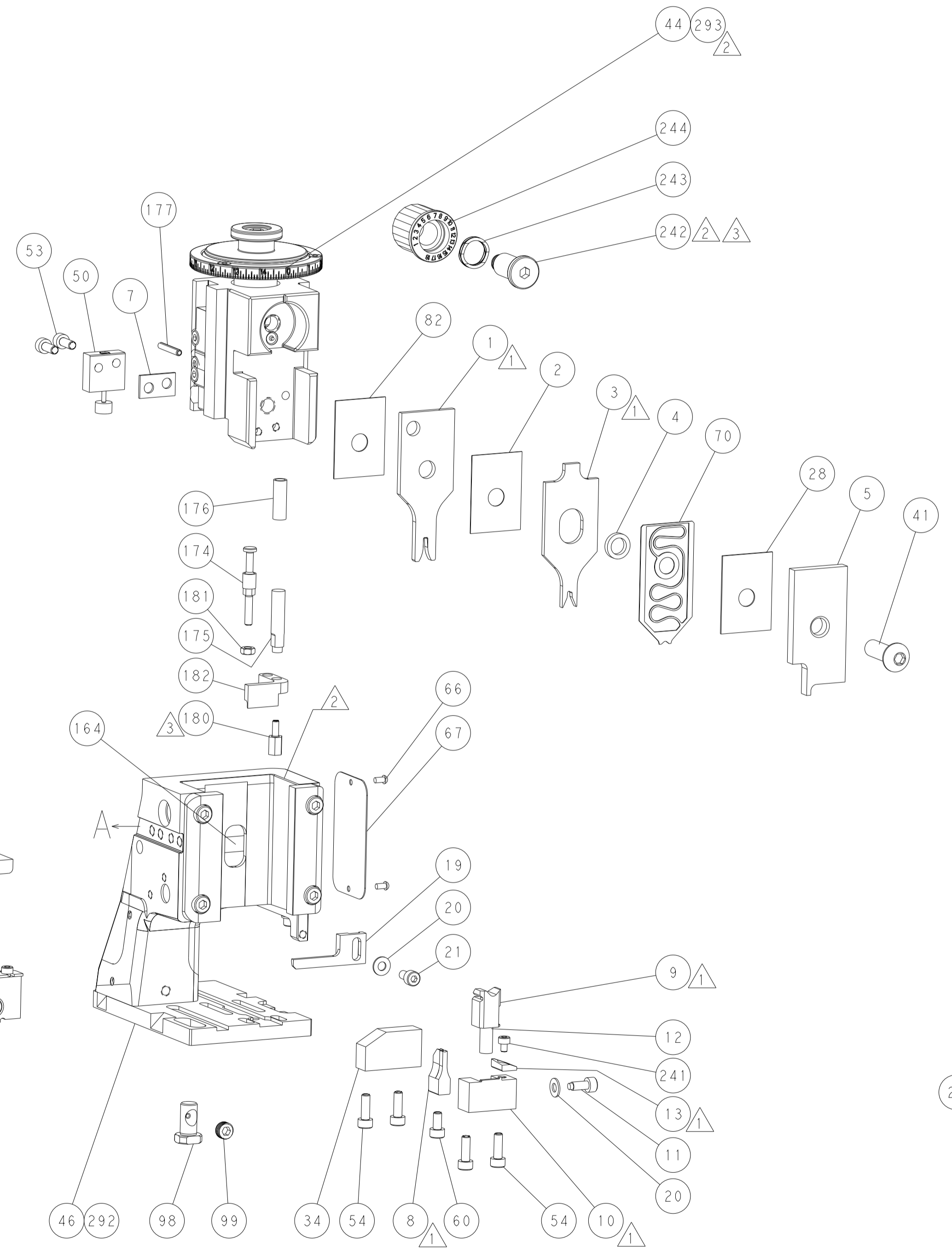
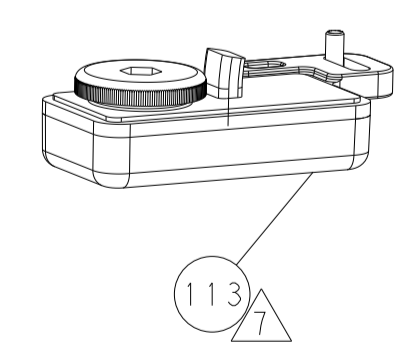
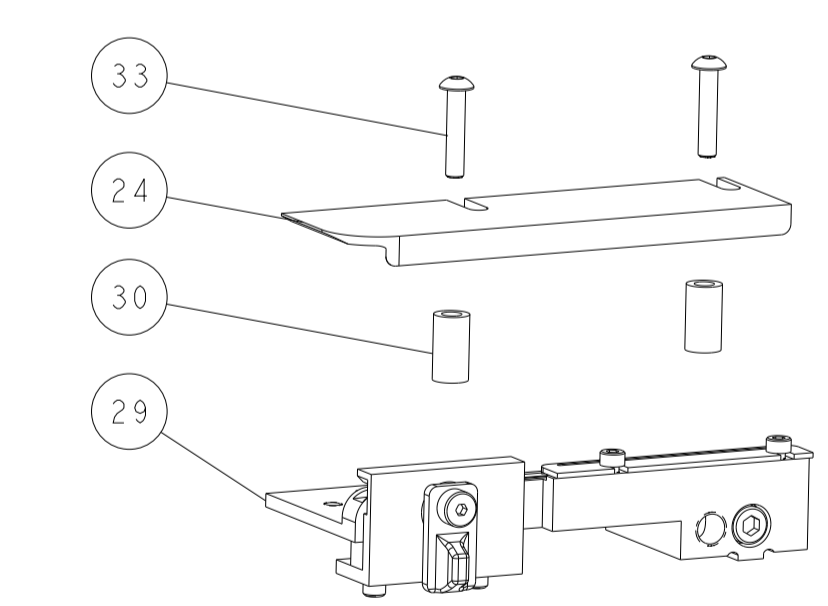

TERMINAL SUPPORT LOCATION

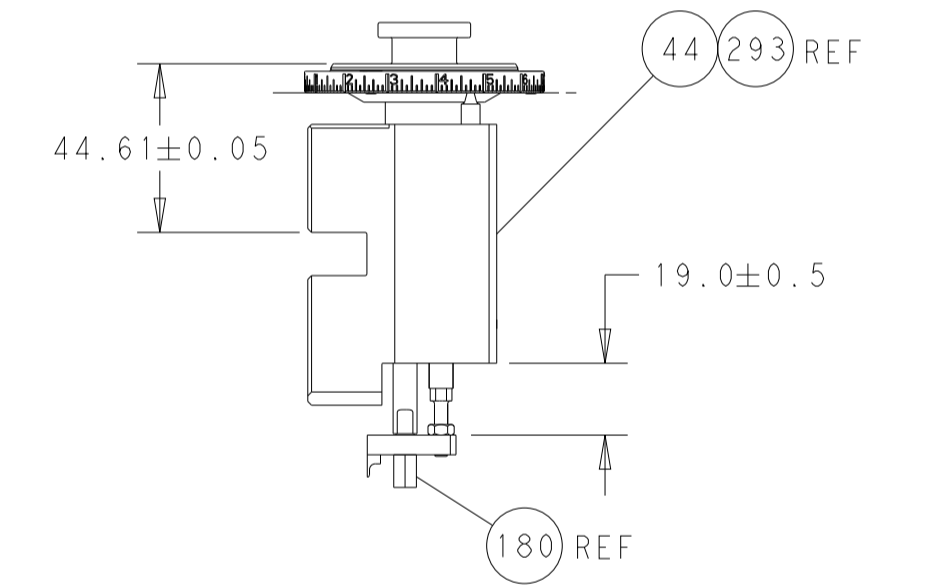

RAM AND HOLD DOWN SET-UP

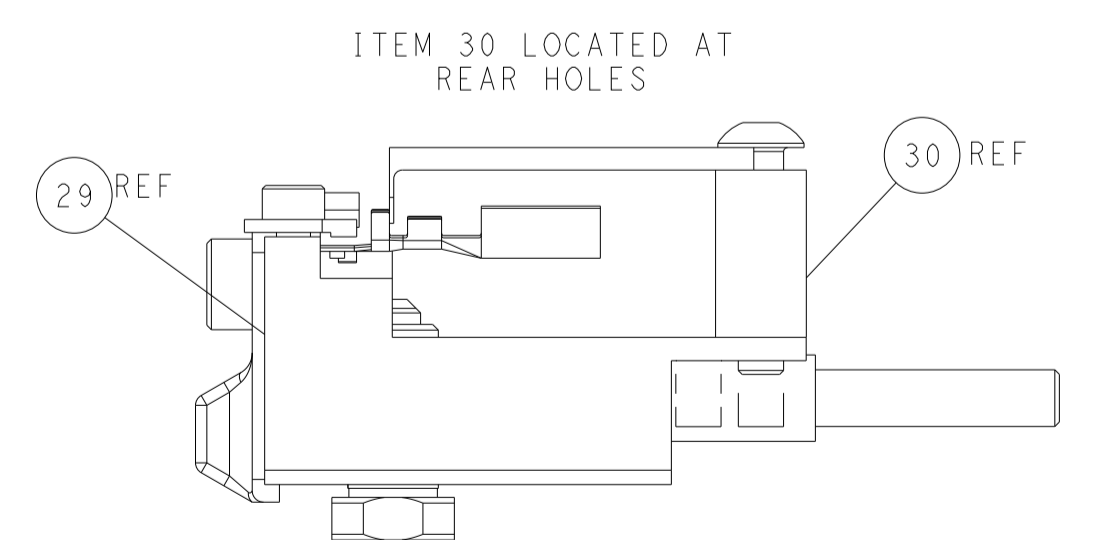

FEED TRACK POSITION GUIDE BY INSULATION BARREL

CAM POSITIONS

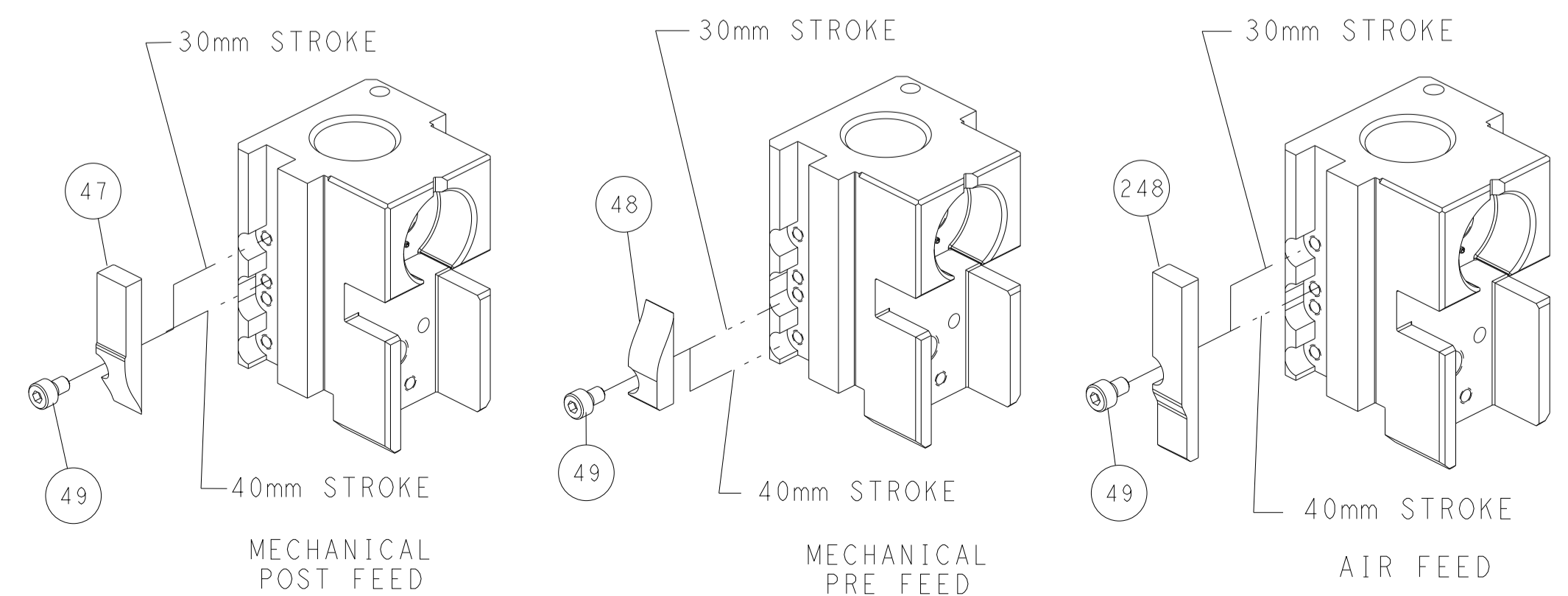

ATLANTIC VERSION
 Shown on sheets 1 of 4 & 2 of 4
 (Pacific version shown on sheets 3 of 4 & 4 of 4)

DIMENSIONS:		TOLERANCES UNLESS OTHERWISE SPECIFIED:		DWG		REV	
mm	0 PLC	±		C. MOYER	10AUG2012	NAME	TE Connectivity
	1 PLC	±		T. ELBIN	10AUG2012	SIZE	Harrisburg, PA 17105-3608
	2 PLC	±		T. ELBIN	10AUG2012	SCALE	Customer Accessible Production Drawing
	3 PLC	±				1:2	
	4 PLC	±					
	ANGLES	±					
	FINISH	±					
MATERIAL				WEIGHT			

PART NUMBER	REVISION	DESCRIPTION	FEED TYPE
2-2151164-1	M	FINE CRIMP HEIGHT ADJUST	MECHANICAL
2-2151164-2	M	FINE CRIMP HEIGHT ADJUST	PNEUMATIC
7-2151164-7	F	CRIMP TOOLING KIT	-

PACIFIC VERSION TERMINATOR
 INTERFACE ADAPTER

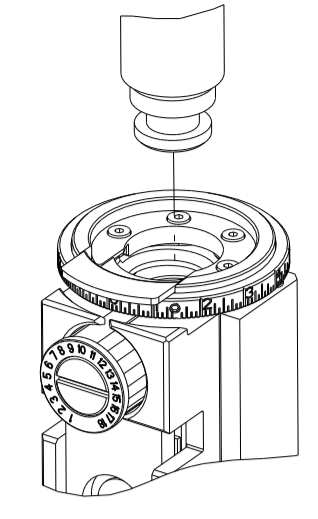

APPLICATOR DATA		
CRIMP	SIZE	TYPE
WIRE	2.03 mm [.080]	F
INSUL	2.54 mm [.100]	OV
APPLICATOR INSTRUCTIONS 408-35042		

TERMINAL DATA: TE TERMINAL		TE CRIMP SPECIFICATION	
TERMINAL NAME: 2.8MM SENSOR - FLAT TYPE RECEPTACLE			
WIRE STRIP LENGTH		INSULATION DIAMETER RANGE	
4.00-4.60 mm [.157-.181 IN]		Ø1.30-2.10 mm [.051-.083 IN]	
TERMINAL APPLICATION SPECIFICATION	114-18144-0	-	-
TERMINALS APPLIED			
TE TERMINAL	TE TERMINAL	TE TERMINAL	TE TERMINAL
967702-1	967702-2	-	-

TERMINAL DATA: TE TERMINAL		TE CRIMP SPECIFICATION	
TERMINAL NAME: 2.8MM SENSOR - FLAT TYPE RECEPTACLE			
WIRE STRIP LENGTH		INSULATION DIAMETER RANGE	
4.00-4.60 mm [.157-.181 IN]		Ø1.30-2.10 mm [.051-.083 IN]	
TERMINAL APPLICATION SPECIFICATION	114-18148	-	-
TERMINALS APPLIED			
TE TERMINAL	TE TERMINAL	TE TERMINAL	TE TERMINAL
1-968849-1	1-968849-2	1-968849-2	1-1355833-1

WIRE SIZE	CRIMP HEIGHT mm [INCH]	CRIMP HEIGHT REFERENCE SETTING
1.00mm2	1.20+/-0.05 [.047+/- .002]	6.5
0.75mm2	1.18+/-0.05 [.046+/- .002]	6.5
0.50mm2	1.15+/-0.05 [.045+/- .002]	7.0

WIRE SIZE	CRIMP HEIGHT mm [INCH]	CRIMP HEIGHT REFERENCE SETTING
0.85mm2 CAVS	1.26+/-0.03 [.050+/- .001]	6.0
0.85mm2 AVS	1.24+/-0.03 [.049+/- .001]	6.2
0.75mm2 AESSX-F	1.23+/-0.03 [.048+/- .001]	6.4
AWG 18	1.23+/-0.03 [.048+/- .001]	6.5
1.00mm2	1.20+/-0.05 [.047+/- .002]	6.5
2x 0.50mm2	1.20+/-0.05 [.047+/- .002]	6.5
0.75mm2	1.18+/-0.05 [.046+/- .002]	6.7
0.50mm2	1.15+/-0.05 [.045+/- .002]	7.0
0.50mm2	1.14+/-0.03 [.045+/- .001]	7.1
0.50mm2	1.12+/-0.03 [.044+/- .001]	7.3
AWG 20	1.08+/-0.05 [.043+/- .002]	7.8

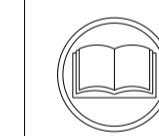

- RECOMMENDED SPARE PARTS
- REFER TO SUPPLIED INSTRUCTION SHEET FOR CLEANING, LUBRICATION AND STORAGE OF APPLICATOR.
- APPLY PART NUMBER 2-23419-6 LOCTITE TO THREADS OF ITEM 242.
- CRIMP HEIGHT REFERENCE SETTING WAS THE SETTING USED WHEN THE APPLICATOR WAS QUALIFIED AT THE FACTORY. ADJUSTMENT MAY BE NECESSARY WHEN RUNNING APPLICATOR IN THE FIELD.
- 5. UNLESS SPECIFIED OTHERWISE TORQUE VALUES SHALL BE USED PER DOCUMENT, 101-35000.
- THIS CRIMP PARAMETER IS PROVIDED TO MEET A CUSTOM AND UNIQUE CUSTOMER REQUIREMENT. IT HAS BEEN EVALUATED AND IS CONDITIONALLY SPECIFIED BY TE CONNECTIVITY. THIS CUSTOMIZED CRIMP PARAMETER IS NOT LISTED AS AN APPROVED APPLICATION WITHIN A TE CONNECTIVITY APPLICATION SPECIFICATION; HOWEVER, IT HAS BEEN VALIDATED ACCORDING TO TE CONNECTIVITY SPECIFICATIONS 109-18079 (TEST GROUP 1) AND 114-18022. **TE CONNECTIVITY EXPRESSLY DISCLAIMS ANY AND ALL WARRANTIES THAT THE PRODUCT WILL PERFORM SIMILARLY TO VALIDATED AND APPROVED APPLICATIONS, AS STATED WITHIN TE CONNECTIVITY APPLICATION SPECIFICATIONS, INCLUDING BUT NOT LIMITED TO IMPLIED WARRANTIES OF MERCHANTABILITY OR FITNESS FOR PARTICULAR PURPOSE.** AS SUCH, IT IS HIGHLY RECOMMENDED THAT THE CUSTOMER PERFORM FURTHER DETAILED EVALUATION TO ASSESS PRODUCT PERFORMANCE IN THE SPECIFIC APPLICATION.
- TERMINAL LUBRICANT IS RECOMMENDED.
- WIRE TYPES AEX-F, AESSX-F, AVS.
- WIRE TYPES AEX, CAVS.

***WARNING**
 ON INSTALLATION, SET WIRE DISC TO CRIMP HEIGHT REFERENCE SETTING FOR LARGEST WIRE SIZE. CRIMP HEIGHT REFERENCE SETTINGS GREATER THAN THE VALUE SHOWN MAY CAUSE DAMAGE TO THE CRIMP TOOLING. REFER TO THE INSTRUCTION SHEET FOR PROPER SETUP AND ADJUSTMENTS.

LOC	DIST	REVISIONS					
A	66	P	LTN	DESCRIPTION	DATE	OWN	APVD
-	-	-	-	SEE SHEET 1	-	-	-

-	1	1	2119082-8	CAM, SNAIL, INSULATION ADJUSTMENT	244
-	1	1	2079764-1	WASHER, WAVE SPRING, CREST-TO-CREST	243
-	1	1	2119083-1	RETAINER, INSULATION DIAL	242
-	1	1	7-18023-7	SCR, SKT HD CAP M3 X 4.0	241
-	-	1	2119580-1	MECHANICAL FEED ASSEMBLY	239
-	1	-	2844940-1	AIR FEED MODULE	238
-	REF	REF	994970-2	COUNTER, MAGNETIC	164
-	1	-	2119641-2	FEED CAM, AIR FEED	151
-	1	1	2168083-8	SCR, SKT HD CAP, RoHS, M4 X 16	144
-	4	4	2168083-9	SCR, SKT HD CAP, RoHS, M4 X 20	143
-	-	1	2119653-2	FEED CAM, POST FEED	142
-	1	1	1-1803583-0	APPLICATOR BASIC ASSEMBLY, SF	141
-	1	1	1803516-1	RAM ASSEMBLY, SF PACIFIC	140
-	1	1	2119955-1	ASSY, LUBRICATOR, SIDE FEED	113
-	1	1	2844908-1	SCREW, LOCKING	99
-	1	1	2844907-1	POST, LOCKING	98
-	1	1	455888-5	SPACER, CRIMPER	82
-	1	1	1803607-3	DOCUMENTATION PACKAGE	71
-	1	1	2119791-9	DEPRESSOR, WIRE	70
-	1	1	2119740-1	TAG, IDENTIFICATION	67
-	2	2	2168078-1	SCREW, DRIVE, RH, RoHS, 2 x .188	66
-	1	1	5-18022-5	SCR, HEX HD CAP, M4 X 6.0	59
-	1	1	1338685-1	PAWL, FEED	56
-	2	2	1-2168083-0	SCR, SKT HD CAP, RoHS, M4 X 10	53
-	1	1	1803382-2	HOLD DOWN, SPRING LOADED	50
-	1	2	18023-9	SCR, SKT HD CAP M4 X 6.0	49
-	-	1	2119652-1	FEED CAM, PRE FEED	48
-	1	1	1803602-1	SCR, BHSC, RoHS (M8 X 25)	41
-	1	1	1-1752356-6	SUPPORT, TERMINAL	34
-	2	2	2079383-5	SCR, BHSC, RoHS (M4 X 20)	33
-	2	2	2-2844962-8	SPACER, CYLINDRICAL, STRIP GUIDE	30
-	1	1	2844992-2	ASSEMBLY, STRIP GUIDE	29
-	1	1	455888-6	SPACER, CRIMPER	28
-	1	1	1320928-2	STRIP GUIDE	24
-	1	1	2168083-2	SCR, SKT HD CAP, RoHS, M4 X 8.0	21
-	2	2	1-18028-2	WASHER, FLAT, REG M4	20
-	1	1	2119533-1	STRIPPER, SIDE FEED	19
-	1	1	2119806-1	INSERT, SHEAR	13
-	1	1	3-22280-3	SPRING, COMPRESSION	12
-	1	1	1-356885-5	STOP, SHEAR	11
-	1	1	2119805-1	SHEAR HOLDER, FRONT	10
-	1	1	1803095-3	FLOATING SHEAR, FRONT	9
-	1	1	1-1333204-7	ANVIL, COMBINATION	8
-	1	1	3-240641-4	SPACER	7
-	-	-	-	-	6
-	1	1	2119757-3	DEPRESSOR, SHEAR	5
-	1	1	238011-4	BLOCK, CRIMPER SPACER	4
-	1	1	3-1633964-5	CRIMPER, INSULATION OVERLAP PREMIUM	3
-	1	1	455888-4	SPACER, CRIMPER	2
-	1	1	1-456405-5	CRIMPER, WIRE PREMIUM	1

PACIFIC VERSION
 Shown on sheets 3 of 4 & 4 of 4
 (Atlantic version shown on sheets 1 of 4 & 2 of 4)

DIMENSIONS:		TOLERANCES UNLESS OTHERWISE SPECIFIED:		MATERIAL:		FINISH:		WEIGHT:		SCALE:		SHEET:		REV:	
mm	0 PLC ±	1 PLC ±	2 PLC ±	3 PLC ±	4 PLC ±	ANGLES	FINISH	-	-	Customer Accessible Production Drawing	1:2	3	of 4	REV	M1

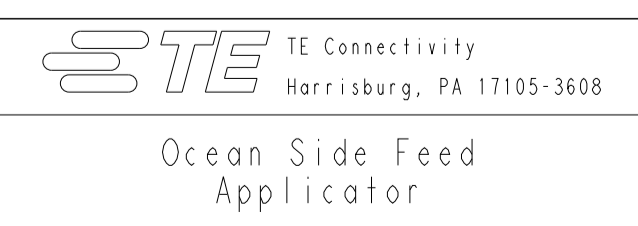

Ocean Side Feed
 Applicator

LOC	DIST	REVISIONS					
A	66	P	LTN	DESCRIPTION	DATE	DWN	APVD
		-		SEE SHEET 1			

FEED TYPE MECHANICAL

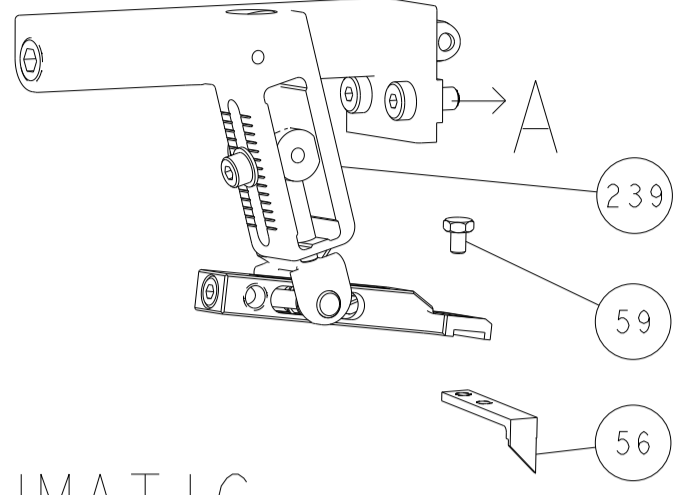

PNEUMATIC

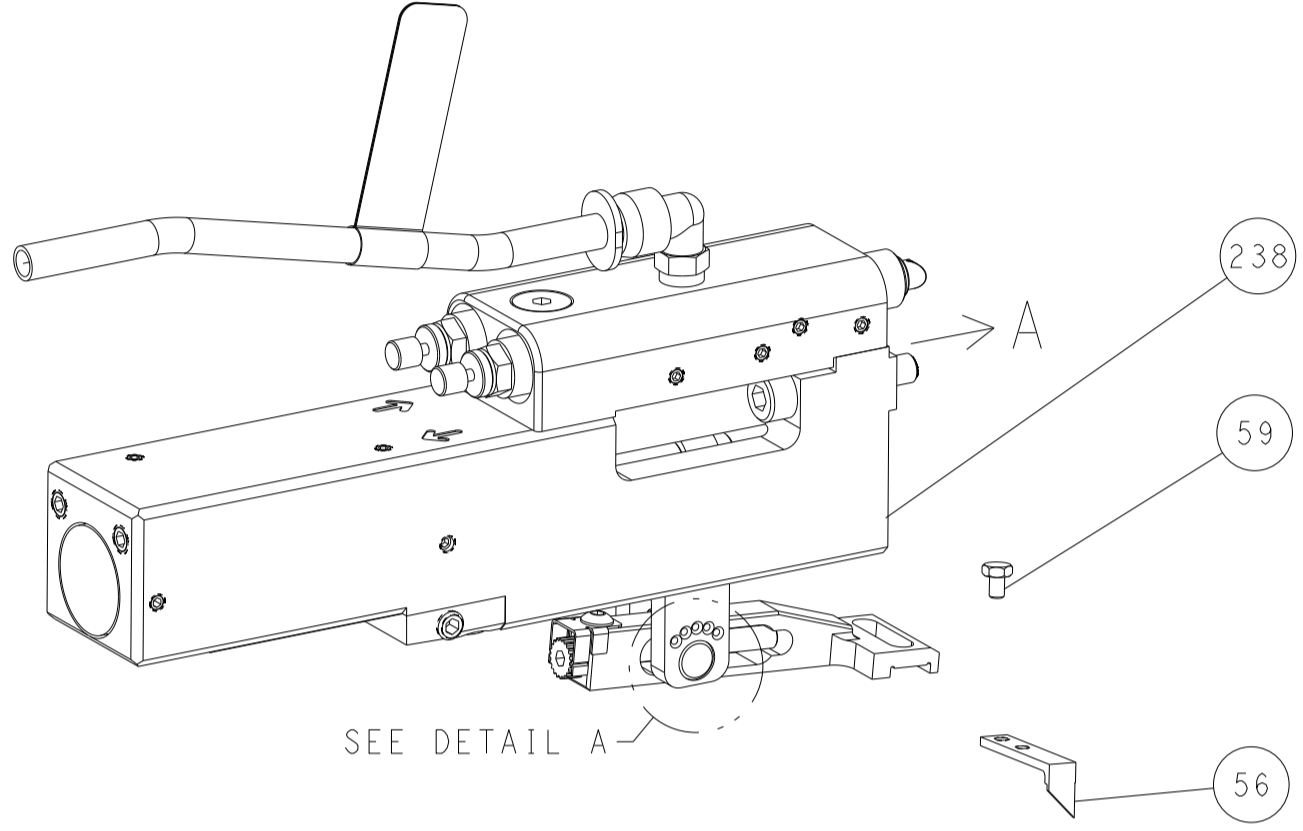

FEED SPRING SETTING POSITION (SHOWN FROM REAR SIDE)

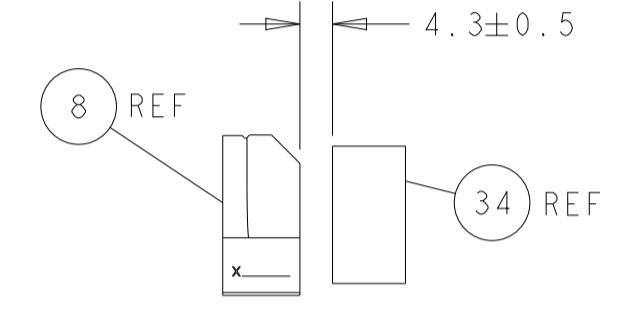
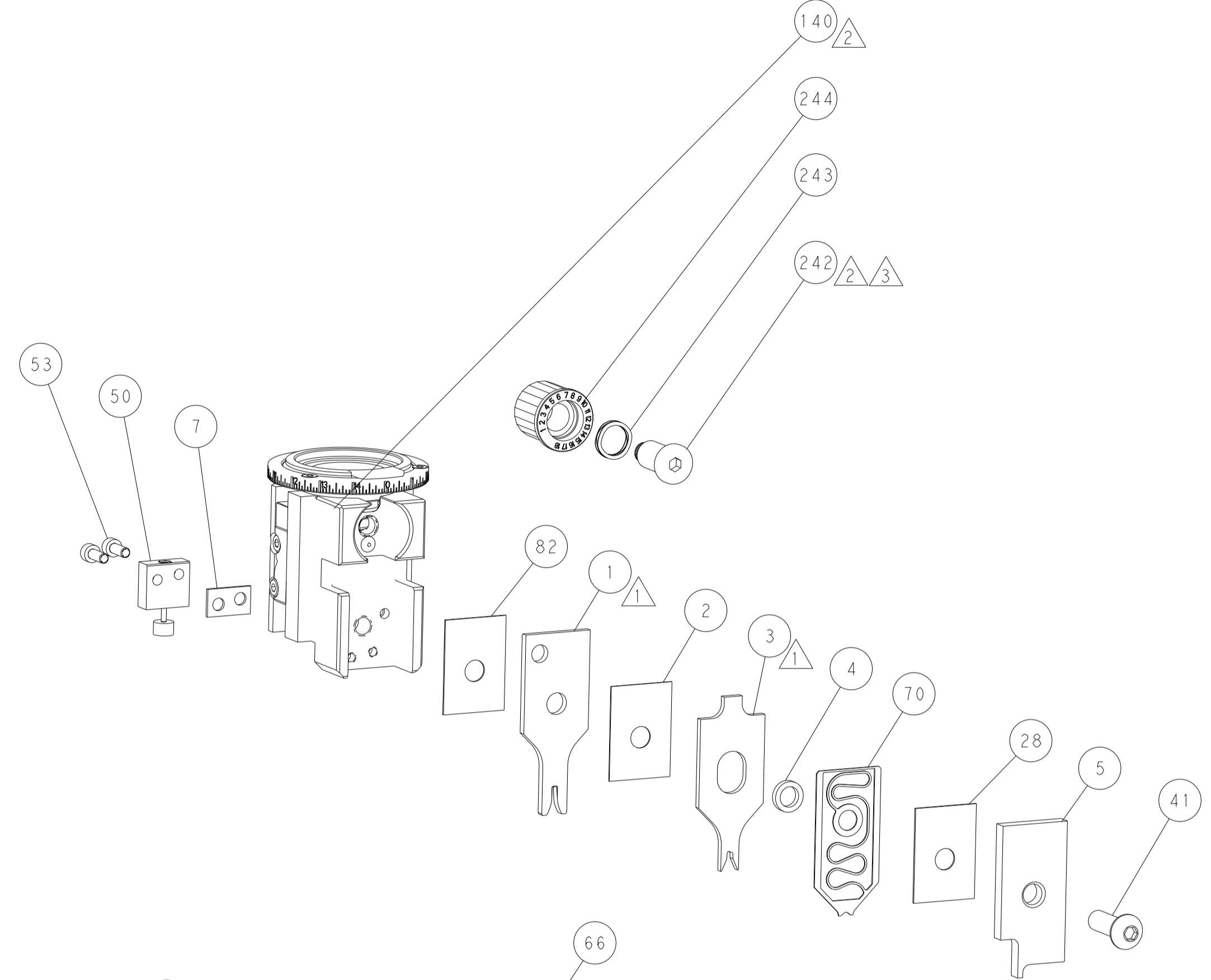
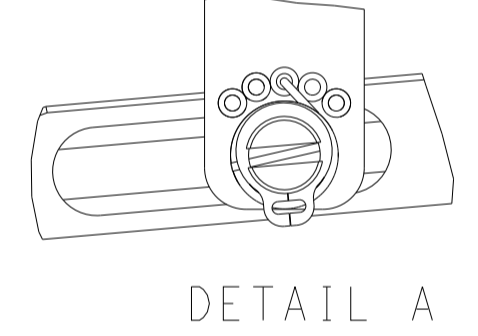

TERMINAL SUPPORT LOCATION

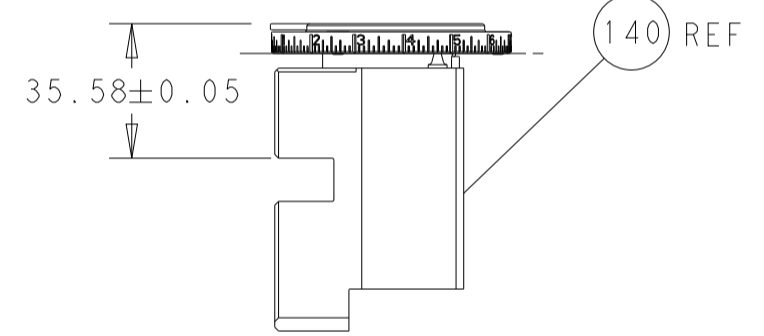

RAM SET-UP

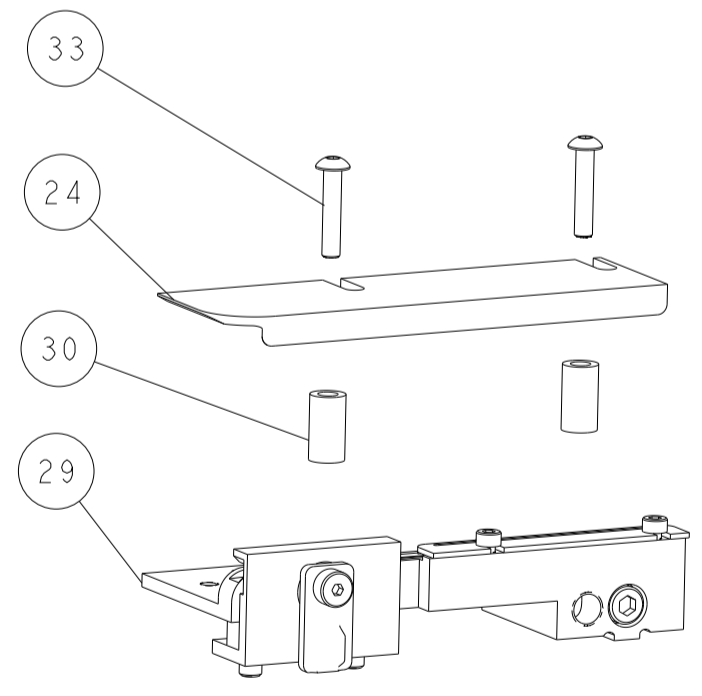

CAM POSITIONS

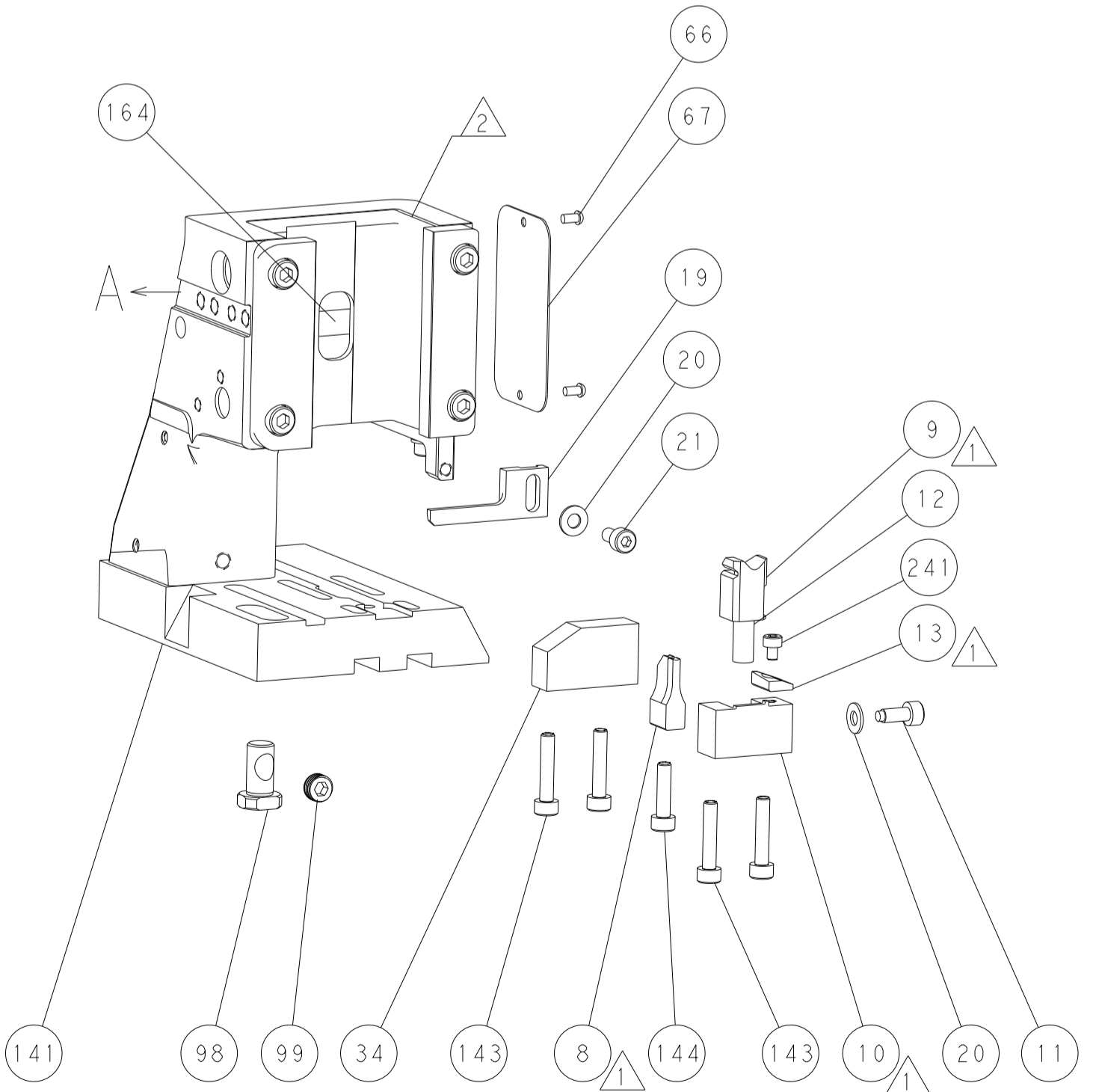
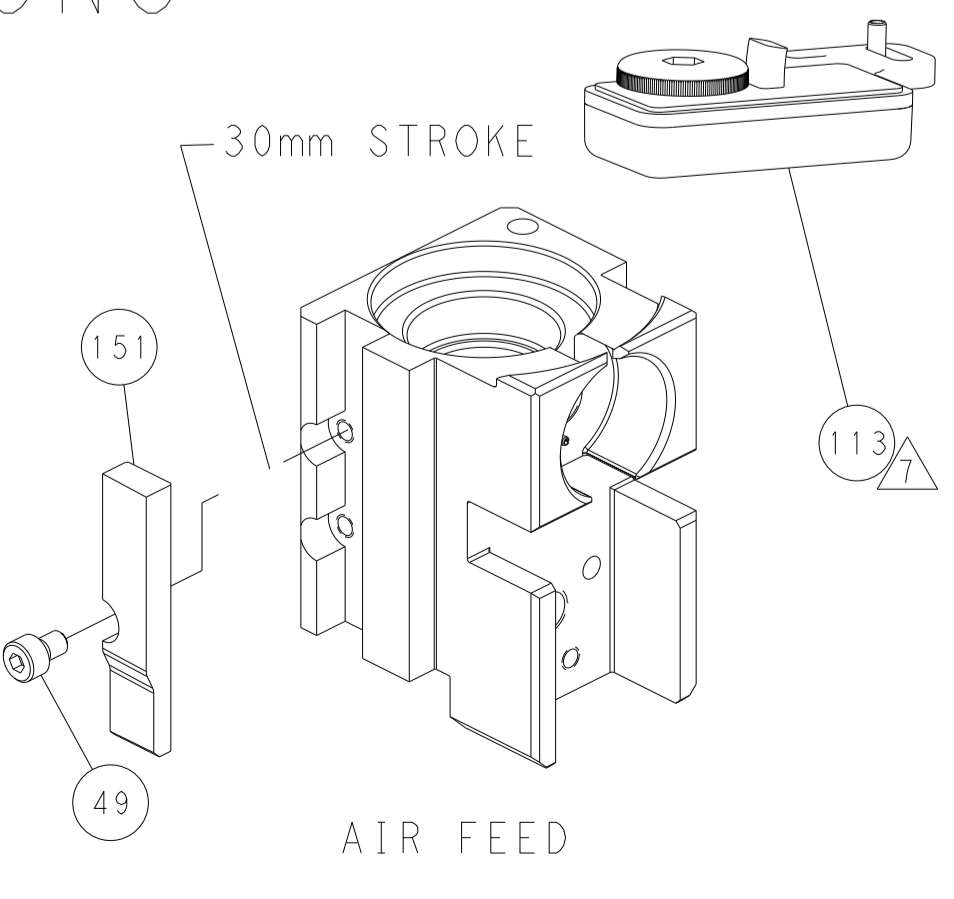
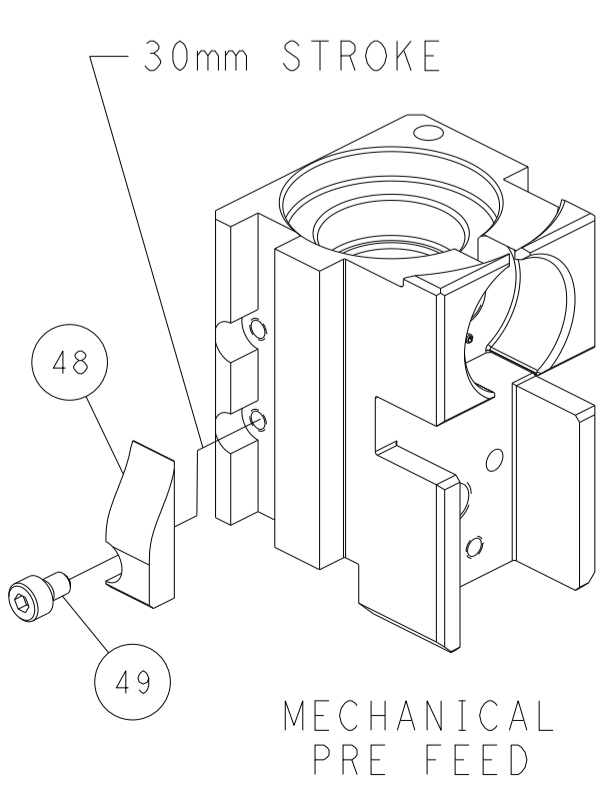
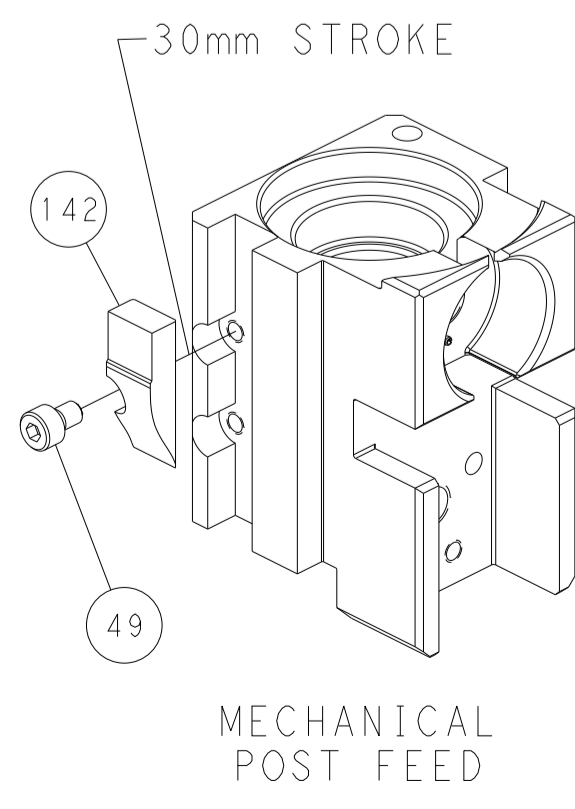

PACIFIC VERSION
 Shown on sheets 3 of 4 & 4 of 4
 (Atlantic version shown on sheets 1 of 4 & 2 of 4)

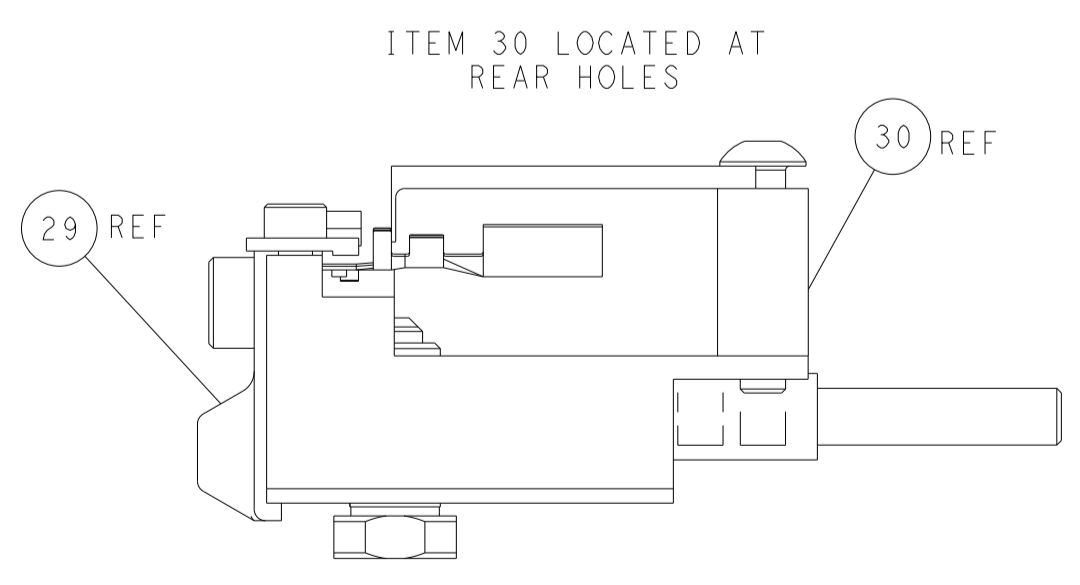

FEED TRACK POSITION GUIDE BY INSULATION BARREL

<small>THIS DRAWING IS A CONTROLLED DOCUMENT FOR TYCO ELECTRONICS CORPORATION. IT IS THE PROPERTY OF TYCO ELECTRONICS CORPORATION AND IS NOT TO BE REPRODUCED OR TRANSMITTED IN ANY FORM OR BY ANY MEANS, ELECTRONIC OR MECHANICAL, INCLUDING PHOTOCOPYING, RECORDING, OR BY ANY INFORMATION STORAGE AND RETRIEVAL SYSTEM, WITHOUT THE WRITTEN PERMISSION OF TYCO ELECTRONICS CORPORATION.</small>		DWN C. MOYER 10AUG2012 CHK T. ELBIN 10AUG2012 APVD T. ELBIN 10AUG2012	NAME Ocean Side Feed Applicator
DIMENSIONS: mm 	TOLERANCES UNLESS OTHERWISE SPECIFIED: 0 PLC ± 1 PLC ± 2 PLC ± 3 PLC ± 4 PLC ± ANGLES ± FINISH	SIZE A1 00779 ©=2151164	RESTRICTED TO Customer Accessible Production Drawing
MATERIAL	WEIGHT	SCALE 1:2	SHEET 4 OF 4 REV. M1