



Test Procedure for the NV47711PDAJGEVB Evaluation Board

Test Procedure:

1. Connect the test setup as is shown in **Figure 1**. See **Table 1** with required equipment.
 - Letter **F** – Force line
 - Letter **S** – Sense line
2. Select output current limit by connecting jumper **J₅ – J₈**.
 - **J₅** – $I_{LIM0} \sim 10$ mA
 - **J₆** – $I_{LIM1} \sim 170$ mA
 - **J₇** – $I_{LIM2} \sim 340$ mA
 - **J₈** – I_{LIM3} – R_{CSO3} position available for individual current limit setting by resistor from range 728 Ω to 25.5 k Ω
3. Set Input Voltage and turn on Power Supply.
4. Enable chip by connecting external Voltage Source on jumper **J₃**. Output voltage must be higher than 2.31 V but **maximally 7 V**.
5. Set load current (max 350 mA) and turn on Load.
6. Monitor Output voltage, it's given according to Equation 1.

$$V_{out} = 1.275 \left(1 + \frac{R_1}{R_2} \right) \quad (\text{eq. 1})$$

7. Monitor CSO voltage on connector **J₄**. It should be max 2.55 V in steady state. The CSO voltage is proportional to output current according to Equation 2.

$$V_{CSO} = I_{out} \left(R_{CSO} \times \frac{1}{100} \right) \quad (\text{eq. 2})$$

8. Compare your results with measured results in **Table 2**.

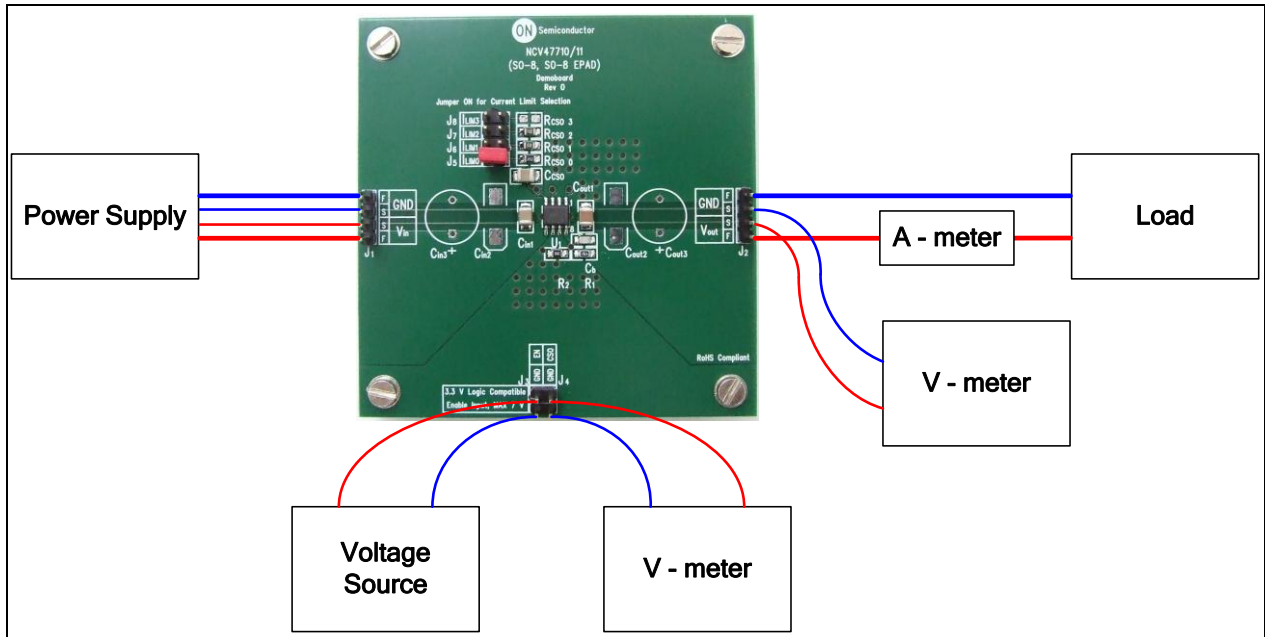

Figure 1. Test Setup

Table 1: Required Equipment

Equipment	Ranges
Power Supply	0 V – 45 V / 500 mA
Voltage Source	0 V – 7 V
Load	0 mA – 500 mA
V - meter	0 V – 20 V
A - meter	0 mA – 500 mA

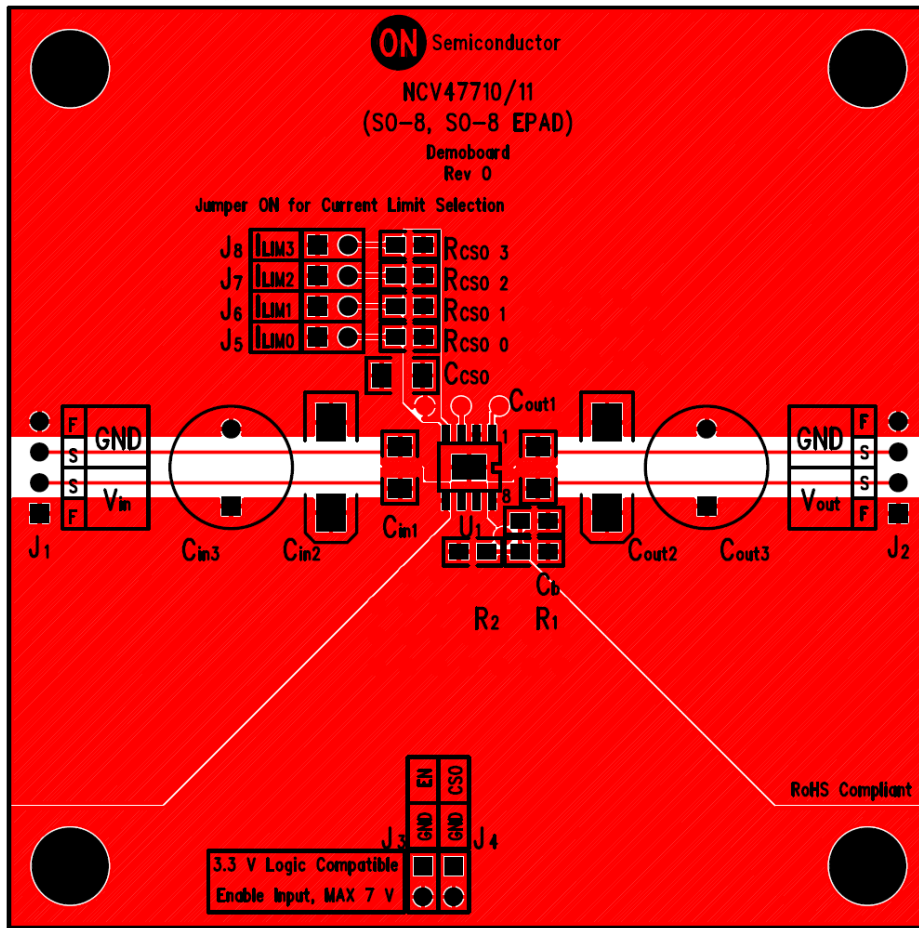

Figure 2. PCB Layout

Table 2: Measured Results

Parameter	Test Conditions	Value		Unit
		Nominal	Measured	
Output Voltage	$V_{in} = 13.5 \text{ V}$, $V_{out_nom} = 5.02 \text{ V}$, $I_{out} = 5 \text{ mA}$, $R_{CSO} = \text{Short to ground}$	5.02	5.03	V
	$V_{in} = 13.5 \text{ V}$, $V_{out_nom} = 5.02 \text{ V}$, $I_{out} = 350 \text{ mA}$, $R_{CSO} = \text{Short to ground}$	5.02	5.04	
Output Current	$V_{in} = 13.5 \text{ V}$, $V_{out_nom} = 5.02 \text{ V}$, $V_{out} = 0 \text{ V}$, $R_{CSO} = 25.5 \text{ k}\Omega$	10	10.45	mA
	$V_{in} = 13.5 \text{ V}$, $V_{out_nom} = 5.02 \text{ V}$, $V_{out} = 0 \text{ V}$, $R_{CSO} = 1.5 \text{ k}\Omega$	170	175.6	
	$V_{in} = 13.5 \text{ V}$, $V_{out_nom} = 5.02 \text{ V}$, $V_{out} = 0 \text{ V}$, $R_{CSO} = 750 \Omega$	340	353	