

Bi-CMOS Linear Integrated Circuit Silicon Monolithic

TB2941HQ

Maximum Power 49 W BTL × 4ch Audio Power Amp IC

1. Description

The TB2941HQ is a power IC with built-in four-channel BTL amplifier developed for car audio application. The maximum output power P_{OUT} is 49 W using a pure complementary P-ch and N-ch DMOS output stage.

In addition, a standby switch, a mute function, output offset voltage detector, high-side switch and various protection features are included.

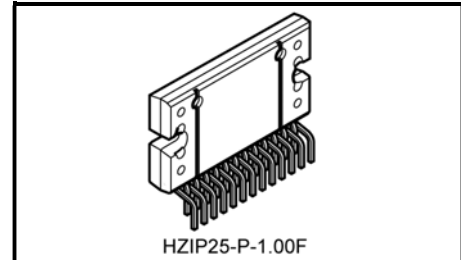

Weight: 7.7 g (typ.)

2. Applications

Power Amp IC developed for car audio applications.

3. Features

- High output power, low distortion, and low noise property (for details, refer to the Table 1 Typical Characteristics).
- Built-in high-side switches. (Pin25) (Note2)
- Built-in detecting output offset voltage. (Pin1,Pin25) (Note2)
- Built-in muting function. (Pin22)
- Built-in auto muting functions (for low V_{CC} and stand-by sequence)
- Built-in stand-by switch. (Pin4)
- Built-in various protection circuits (thermal shut down, over-voltage, short to V_{CC} , short to GND, and output to output short)

Table 1 Typical Characteristics (Note1)

Test condition	Typ.	Unit
Output power (P_{OUT})		
$V_{CC} = 15.2 \text{ V}$, JEITA max	49	W
$V_{CC} = 13.7 \text{ V}$, JEITA max	40	
THD = 10%	24	
Output power (P_{OUT}) ($R_L = 2 \Omega$)		
$V_{CC} = 13.7 \text{ V}$, JEITA max	73	W
THD = 10%	45	
Total harmonic distortion (THD)		
$P_{OUT} = 4 \text{ W}$	0.006	%
Output noise voltage (V_{NO}) ($R_g = 0 \Omega$)		
Filter : DIN AUDIO	65	μVrms
Operating Supply voltage range (V_{CC})		
$R_L = 4 \Omega$	6 to 18	V
$R_L = 2 \Omega$	6 to 16	

Note1:

Typical test conditions: $V_{CC} = 13.2 \text{ V}$, $f = 1 \text{ kHz}$, $R_L = 4 \Omega$, $T_a = 25^\circ\text{C}$; unless otherwise specified.

R_g : signal source resistance

Note2:

Pin25 functions are selected by mute terminal (pin 22) voltage.

4. Block Diagram

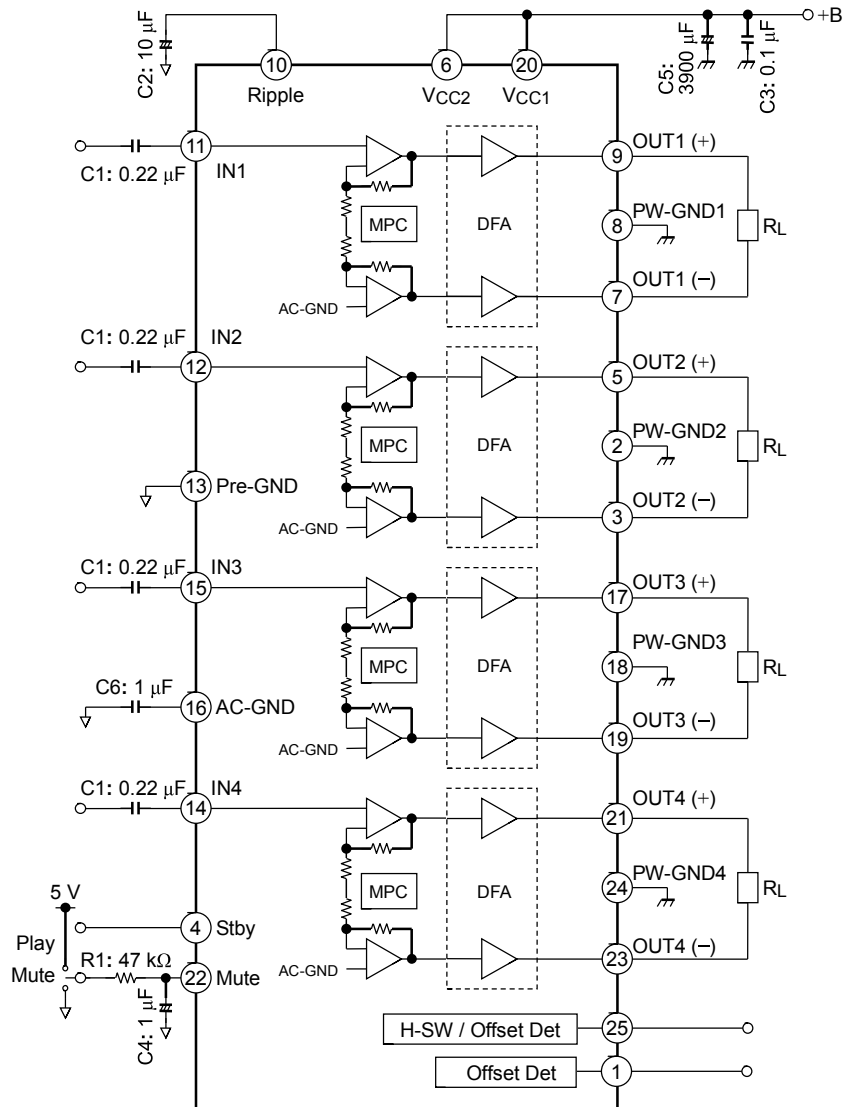

Some of the functional blocks, circuits or constants labels in the block diagram may have been omitted or simplified for clarity.

In the following explanation, a "channel" is a circuit which consists of INx, OUTx (+), OUTx (-), and PW-GNDx. (x:1 to 4)

5. Pin Configuration and Function Descriptions

5.1 Pin Configuration (top view)

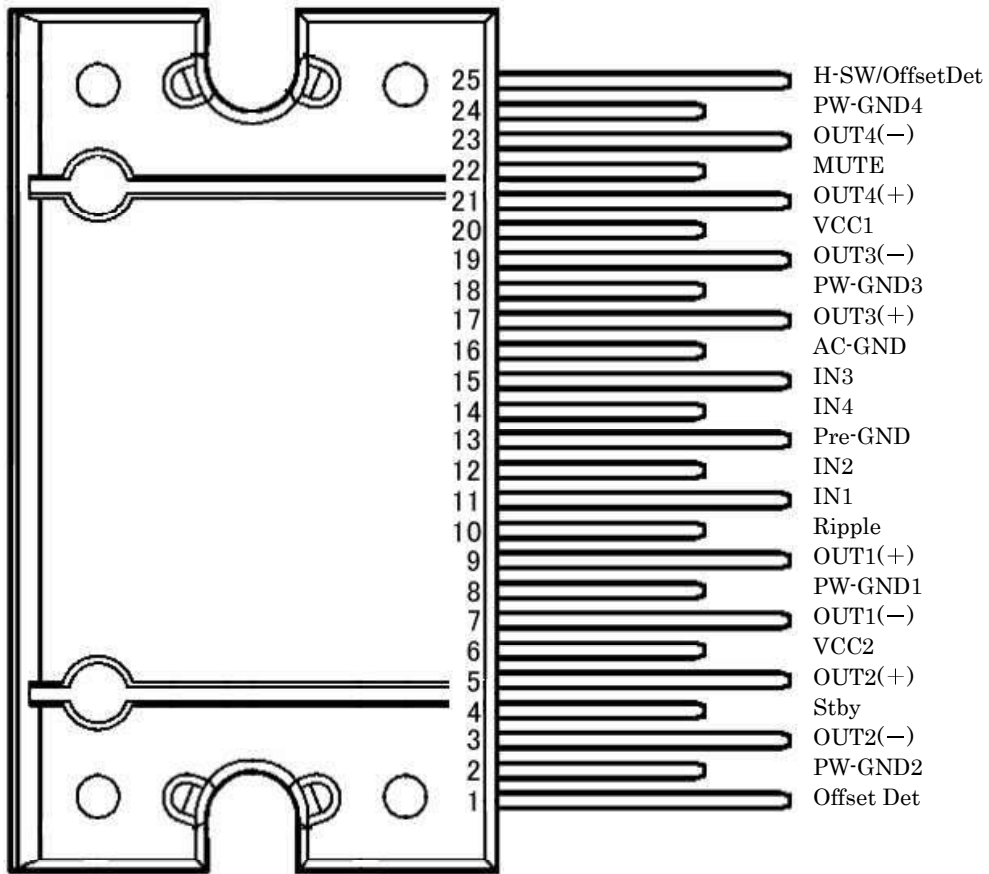

5.2 Pin Function Descriptions

Pin	Symbol	I/O (Note1)	Description
1	Offset Det	V _{od} -OUT	Output offset voltage detector output
2	PW-GND2	—	Ground for OUT2
3	OUT2(-)	OUT	OUT2(-) output
4	Stby	V _{ST} -IN	Stand-by voltage input
5	OUT2(+)	OUT	OUT2(+) output
6	VCC2	V _{CC} -IN	Supply voltage 2
7	OUT1(-)	OUT	OUT1(-) output
8	PW-GND1	—	Ground for OUT1
9	OUT1(+)	OUT	OUT1(+) output
10	Ripple	—	Ripple voltage
11	IN1	IN	OUT1 input
12	IN2	IN	OUT2 input
13	Pre-GND	—	Signal ground
14	IN4	IN	OUT4 input
15	IN3	IN	OUT3 input
16	AC-GND	—	Common reference voltage for all input
17	OUT3(+)	OUT	OUT3(+) output
18	PW-GND3	—	Ground for OUT3
19	OUT3(-)	OUT	OUT3(-) output
20	VCC1	V _{CC} -IN	Supply voltage 1
21	OUT4(+)	OUT	OUT4(+) output
22	MUTE	V _{mute} IN	Mute voltage input
23	OUT4(-)	OUT	OUT4(-) output
24	PW-GND4	—	Ground for OUT4
25	H-SW/OffsetDet	HSW/V _{od} -OUT	High-side switch / Offset detector output

6. Functional Description

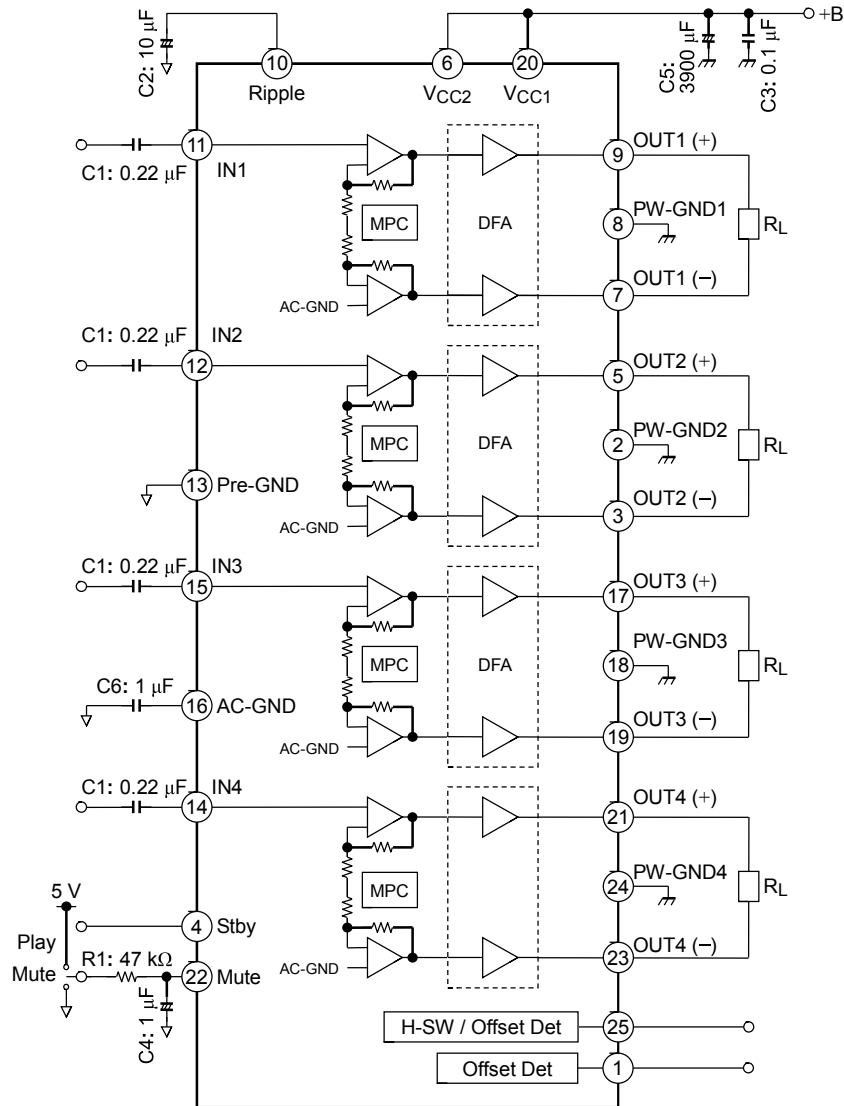

Component Name	Recommended Value	Pin	Purpose	Effect (Note1)	
				Lower than Recommended Value	Higher than Recommended Value
C1	0.22 μF	INx (x:1 to 4)	To eliminate DC	Cut-off frequency becomes higher	Cut-off frequency becomes lower
C2	10 μF	Ripple	To reduce ripple	Turn on/off time shorter	Turn on/off time longer
C3	0.1 μF	VCC1, VCC2	To provide sufficient oscillation margin	Reduces noise and provides sufficient oscillation margin	
C6	1 μF	AC-GND	Common reference voltage for all input	Pop noise is suppressed when C1: C6 = 1:4. (Note2)	
C5	3900 μF	VCC1, VCC2	Ripple filter	Power supply ripple filtering	
R1 / C4	47 kΩ / 1 μF	Mute	Mute ON/OFF Smooth switching	Pop noise becomes larger	Switching time becomes longer

Note1: When the unrecommended value is used, please examine it enough by system evaluation.

Note2: Since "AC-GND" pin is a common reference voltage for all input, this product needs to set the ratio of an input capacitance (C1) and the AC-GND capacitance (C6) to 1:4

Note3: Use the low leak current capacitor for C1 and C6.

7. Standby Function (Pin 4)

The power supply can be turned on or off via pin 4 (Stby). The threshold voltage of pin 4 is below table. The power supply current is about 0.01 μ A (typ.) in the standby state.

Standby Control Voltage (V_{SB}): Pin 4

Stby	Power	V_{SB} (V)
ON	OFF	0 to 0.9
OFF	ON	2.2 to V_{CC}

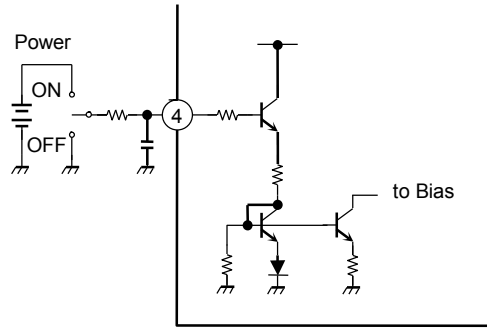

Figure 1 Internal circuit for standby

Benefits of the Standby Switch

- (1) V_{CC} can be directly turned on or off by a microcontroller, eliminating the need for a switching relay.
- (2) Since the control current is minuscule, a low-current-rated switching relay can be used.

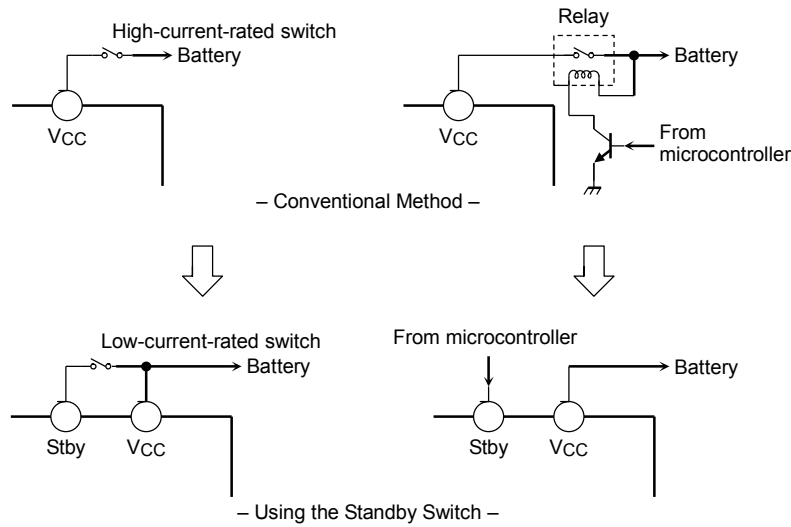

Figure 2 Standby Switch

8. Mute Function (pin 22)

The audio mute function is enabled by setting pin 22 Low. R₁ and C₄ determine the time constant of the mute function. The time constant affects pop noise generated when power or the mute function is turned on or off; thus, it must be determined on a per-application basis. (Refer to Figures 3 and 4.) The value of the external pull-up resistor is determined, based on pop noise value.

For example:

when the control voltage is changed from 5 V to 3.3 V, the pull-up resistor should be: $3.3V/5V \times 47\text{ k}\Omega = 31\text{ k}\Omega$

when the control voltage is changed from 5 V to 8.5 V, the pull-up resistor should be: $8.5V/5V \times 47\text{ k}\Omega = 80\text{ k}\Omega$

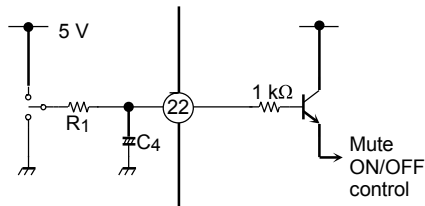

Figure 3 Mute Function

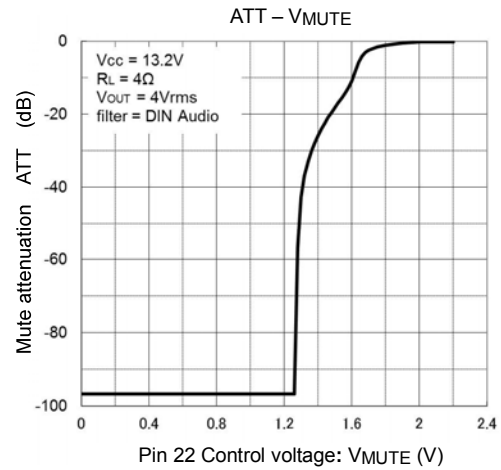

Figure 4 Mute Attenuation – VMUTE (V)

9. Auto Muting Functions

The TB2941HQ has two automatic mute function.

- a) Low Vcc Mute
- b) Stand-by Off Mute.

9.1 Low Vcc Mute

When the supply voltage became lower than 5.5V (Typ.), The TB2941HQ operates the mute circuit automatically. This function prevents the large audible transient noise which is generated by low Vcc

9.2 Standby-Off Mute

The TB2941HQ operates the mute circuit during the standby-off transition. When the ripple voltage reached $V_{cc}/5$, the standby-off mute is terminated. The external mute has to be ON till the internal mute-OFF.

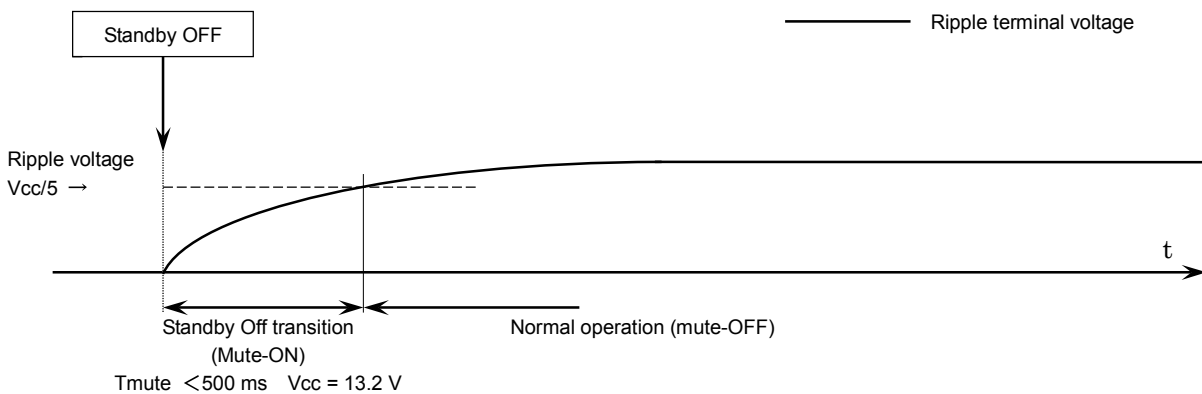

Figure 5 standby-Off Mute

10. High-side Switch (Pin 25)

The high-side switch can be used for many application circuits related to Power-ON.
This function is enabled by mute voltage (Pin 22) less than 6 V.

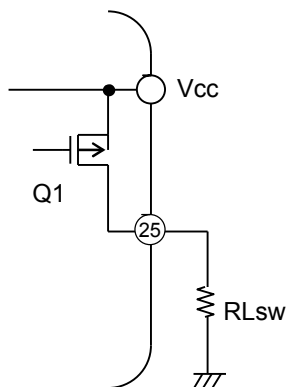
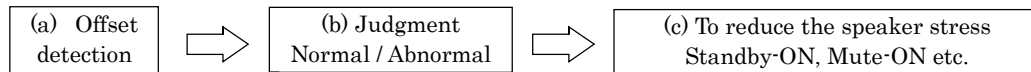

Figure 6 High-side Switch

11. Output DC Offset Detection

This function detects the offset voltage between OUT(+) and OUT(-). The detection result is gotten by pin1 or pin25. When the offset voltage appeared by the external parts accident, for example the leak of coupling capacitor, this function can contribute to a part of safety system to prevent the speaker damage.

The example flowchart: The safety system to prevent damaging to speakers by abnormal offset.



The result of detection does not judge the abnormal offset or not. This function detects only the offset voltage which is decided by specification.

11.1 Offset Circuit

a) Regarding offset detector of Pin25.

The result of output offset voltage detection of Pin25 is gotten by the internal high-side switch which synchronizes with offset voltage. This function is enabled by mute terminal voltage more than 7V.

b) Regarding offset detector of Pin1

The result of output offset voltage detection of Pin1 is gotten by the internal open collector transistor which synchronizes with offset voltage. This function is always available. If this pin does not be used, connect to GND or open.

Figure 8 shows the detected result and audio output waveform.

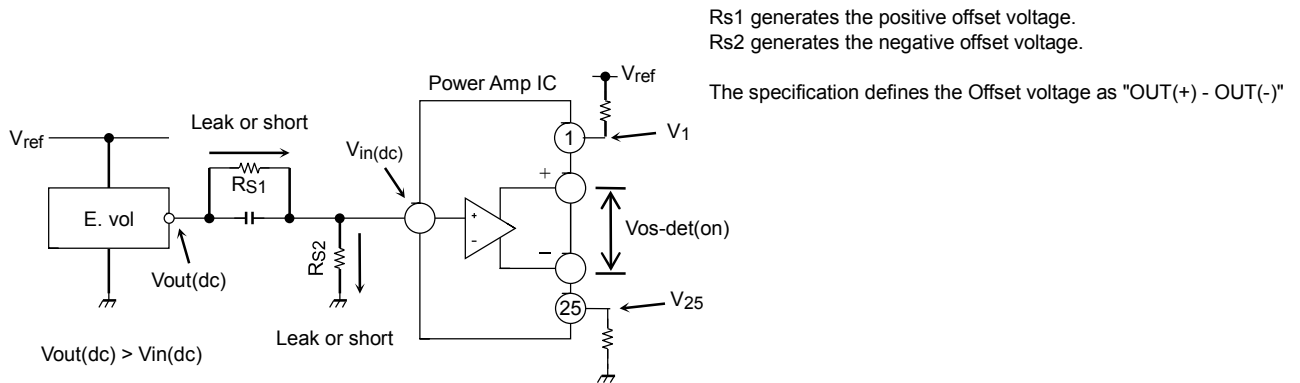

Figure 7 Abnormal output offset voltage

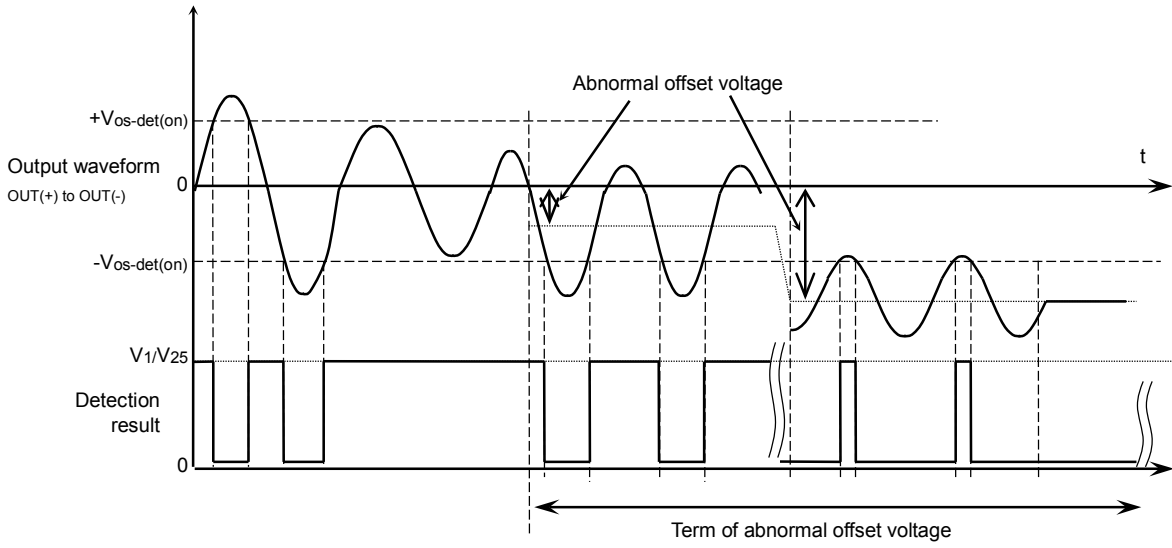

Figure 8 The detected result and audio output waveform

12. Low voltage operation

The TB2941HQ's amplifier circuit is made in MPC/DFA technology. This technology prevents the audible pop noise and sound cutting due to low V_{cc} voltage.

12.1 Description

When the headroom voltage is suppressed by the low V_{cc} , the TB2941HQ switches outputs voltage from $V_{cc}/2$ to $V_{cc}/4$ and reduces the audible pop noise and the sound cutting.

The TB2941HQ can reduce the distortion which is generated by low V_{cc} , because this amplifier circuit keeps the voltage gain of BLT outputs. In other words, if one side output of BTL has the voltage margin, its output can make up for clipped waveform of other side output.

13. Protection Functions

This product has internal protection circuits such as thermal shut down, over-voltage, out to VCC, out to GND, and out to out short circuit protections.

(1) Thermal shut down

It operates when junction temperature exceeds 150°C (typ.).

When it operates, it is protected in the following order.

1. An Attenuation of an output starts first and the amount of attenuation also increases according to a temperature rising,
2. All outputs become in a mute state, when temperature continues rising in spite of output attenuation.
3. Shutdown function starts, when a temperature rise continues though all outputs are in a mute state.

In any case if temperature falls, it will return automatically.

(2) Over-voltage

It operates when voltage exceeding operating range is supplied to VCC pin. If voltage falls, it will return automatically. When it operates, all outputs bias and high-side switch are turned off and all outputs are intercepted. Threshold voltage is 23 V (Typ.)

(3) Short to VCC, Short to GND, Output to output short

It operates when each output pin is in irregular connection and the load line goes over the SOA of power transistor (DMOS). When it operates, all outputs bias circuits are turned off and all outputs are intercepted. If irregular connection is canceled, it will return automatically.

14. Absolute Maximum Ratings

(Ta = 25°C unless otherwise specified)

Characteristics	Condition	Symbol	Rating	Unit
supply voltage (surge)	Max 0.2 s	V _{CC} (surge)	50	V
supply voltage (DC)		V _{CC} (DC)	25	V
supply voltage (operation)		V _{CC} (opr)	18	V
output current (peak)		I _O (peak)	9	A
power dissipation	(Note)	P _D	125	W
Operating temperature range		T _{opr}	-40 to 85	°C
Storage temperature		T _{stg}	-55 to 150	°C

Note: Package thermal resistance R_{th(j-t)} = 1°C/W (typ.) (Ta = 25°C, with infinite heat sink)

The absolute maximum ratings of a semiconductor device are a set of specified parameter values, which must not be exceeded during operation, even for an instant.

If any of these rating would be exceeded during operation, the device electrical characteristics may be irreparably altered and the reliability and lifetime of the device can no longer be guaranteed. Moreover, these operations with exceeded ratings may cause break down, damage, and/or degradation to any other equipment. Applications using the device should be designed such that each maximum rating will never be exceeded in any operating conditions.

Before using, creating, and/or producing designs, refer to and comply with the precautions and conditions set forth in this document.

14.1 Power Dissipation

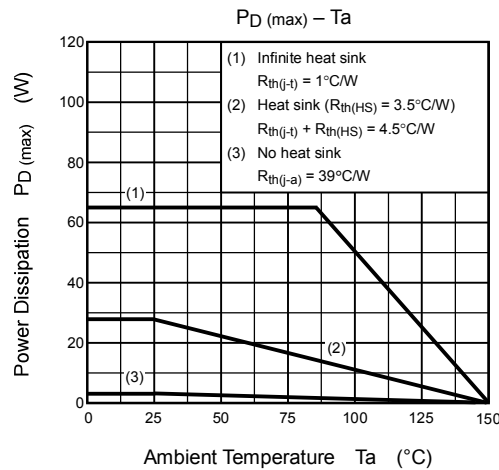

15. Operating Ranges

Characteristics	Symbol	Condition	Min	Typ.	Max	Unit
Supply voltage	V _{CC}	R _L = 4 Ω	6	---	18	V
		R _L = 2 Ω	6	---	16	V

16. Electrical Characteristics

16.1 Amplifier, Common part

($V_{CC} = 13.2\text{ V}$, $f = 1\text{ kHz}$, $R_L = 4\ \Omega$, $T_a = 25^\circ\text{C}$ unless otherwise specified)

Characteristics	Symbol	Test Condition	Min	Typ.	Max	Unit
Quiescent supply current	I_{CCQ}	$V_{IN} = 0\text{ V}$	100	180	300	mA
Output power	$P_{OUT(max)}(1)$	$V_{CC} = 15.2\text{ V}$, max POWER	—	49	—	W
	$P_{OUT(max)}(2)$	$V_{CC} = 13.7\text{ V}$, max POWER	—	40	—	
	$P_{OUT}(1)$	THD = 10%	23	24	—	
Output power($R_L = 2\ \Omega$)	$P_{OUT(max)}(3)$	$V_{CC} = 13.7\text{ V}$, max POWER	—	73	—	W
	$P_{OUT}(2)$	THD = 10%	—	45	—	
Total harmonic distortion	THD (1)	$P_{OUT} = 4\text{ W}$	—	0.006	0.07	%
	THD (2)	$P_{OUT} = 4\text{ W}$, $R_L = 2\ \Omega$	—	0.015	—	
Voltage gain	$G_V(1)$	$V_{OUT} = 0.775\text{ Vrms}$	25	26	27	dB
Channel-to-channel voltage gain	ΔG_V	$V_{OUT} = 0.775\text{ Vrms}$	-1.0	0	1.0	dB
Output noise voltage	$V_{NO}(1)$	$R_g = 0\ \Omega$, DIN AUDIO	—	65	80	μV
	—	—	—	—	—	
Ripple rejection ratio	R.R.	$f_{RIP} = 100\text{ Hz}$, $R_g = 620\ \Omega$ (Note 1) $V_{RIP} = 1\text{ Vrms}$	50	65	—	dB
Crosstalk	C.T.	$P_o = 4\text{ W}$, $R_g = 620\ \Omega$,	—	80	—	dB
Output offset voltage	V_{OFFSET}	—	-90	0	90	mV
Input resistance	R_{IN}	—	—	90	—	k Ω
Standby current	I_{STBY}	$V_{SB} = 0\text{ V}$	—	0.01	1	μA
Mute attenuation	ATTMUTE	MUTE: ON $V_{OUT} = 7.75\text{ Vrms}$ → Mute: OFF	85	100	—	dB
Standby control voltage	V_{SBH}	POWER : ON	2.2	—	V_{CC}	V
	V_{SBL}	POWER : OFF	0	—	0.9	
Mute control voltage	V_{MH}	MUTE : OFF	2.2	—	V_{CC}	V
	V_{ML}	MUTE : ON	0	—	0.9	

Note 1: f_{RIP} : reple frequency

V_{RIP} : Ripple signal voltage (AC fluctuations in the power supply)

16.2 Pin 25 High-side switches, Output DC offset detector

($V_{CC} = 13.2\text{ V}$, $f = 1\text{ kHz}$, $R_L = 4\ \Omega$, $I_{O-HSW} = 400\text{ mA}$, $T_a = 25^\circ\text{C}$ unless otherwise specified)

Characteristics	Symbol	Test Condition	Min	Typ.	Max	Unit
HSW maximum current	$I_{O-HSW}(\text{MAX})$	$V_{O-HSW} = 12.6\text{ V}$	400	—	—	mA
HSW I/O voltage ratio	ΔV_O	—	—	0.2	0.6	V
Function switching control voltage	$V_M(\text{HSW})$	enable HSW	2.2	—	6.0	V
	$V_M(\text{DET})$	enable Vos Det	7.0	—	V_{CC}	
DC offset threshold voltage	$V_{OS-DET(ON)}$	$V_M = 8\text{ V}$, $V_{o(+)} - V_{o(-)}$	± 2.5	± 3	± 3.5	V

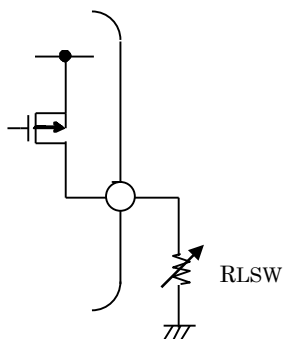

High side switch test circuit 1

16.3 Pin 1 Output DC offset detector

(VCC = 13.2 V, f = 1 kHz, RL = 4 Ω, Rpull-up = 10 kΩ, Vsb = Vref = 5 V Ta = 25°C unless otherwise specified)

Characteristics	Symbol	Test circuit	Test Condition	Min	Typ.	Max	Unit
DC offset threshold voltage	Vos1-det(on)	(5)	Vsb = 5 V, Vo(+) - Vo(-)	±2.5	±3.0	±3.5	V
Pin 1 Saturation voltage	P1-sat	(5)	Rpull-up = 10 kΩ, Vref = 5.0 V Active low	—	100	500	mV

Test circuit (5)

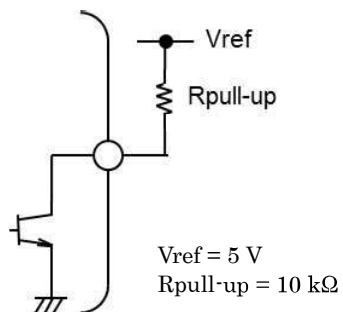

17. Test Circuit

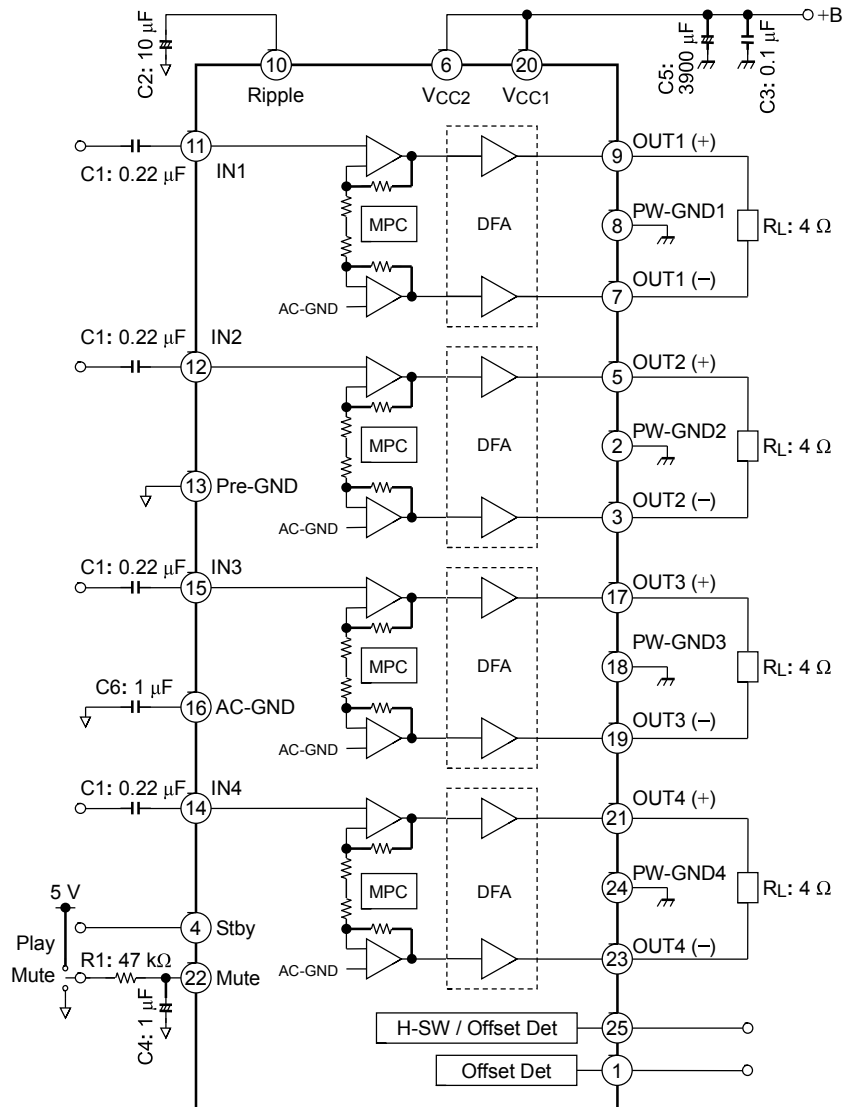

Components in the test circuit are only used to determine the device characteristics.
It is not guaranteed that the system will work properly with these components.

18. Characteristics Curve data

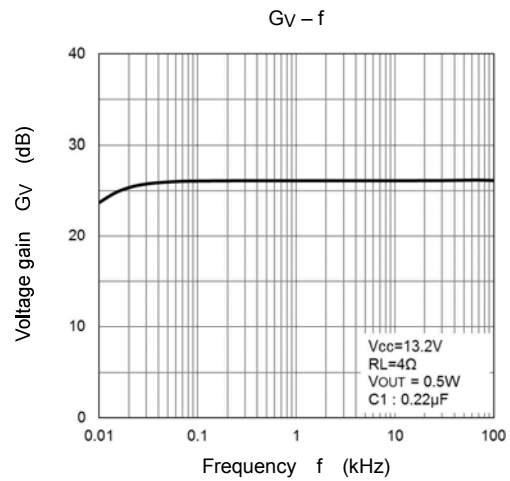
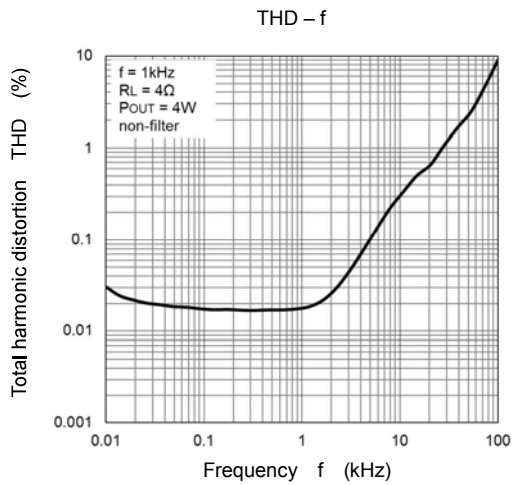
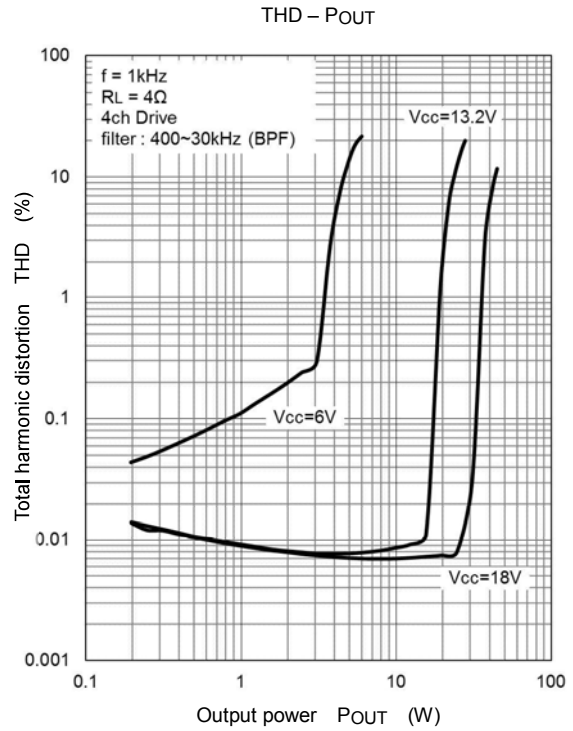
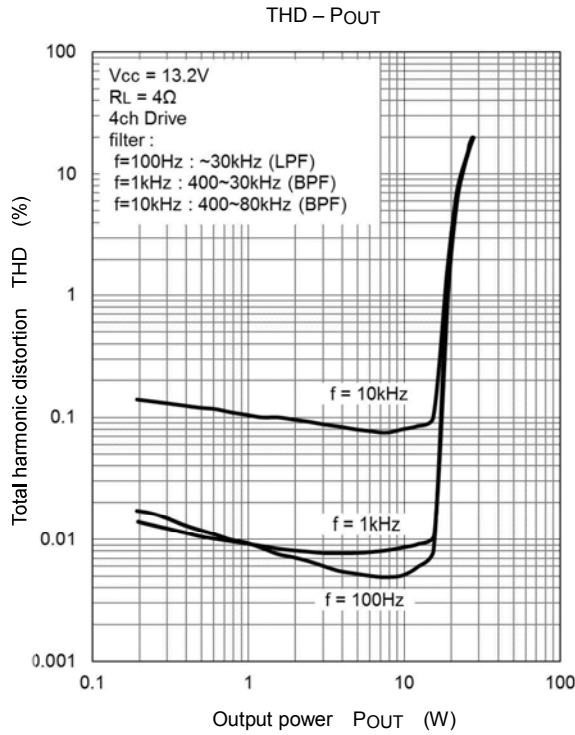

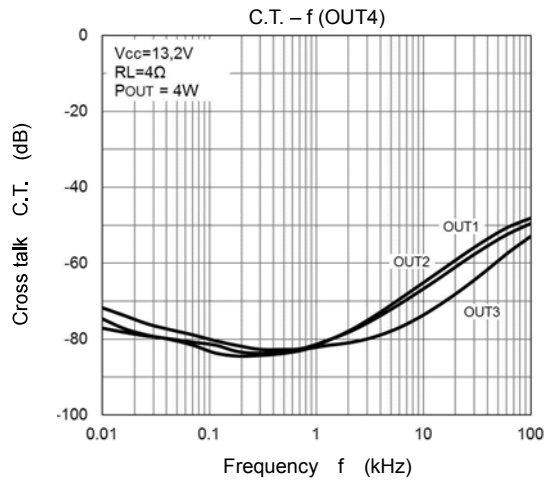
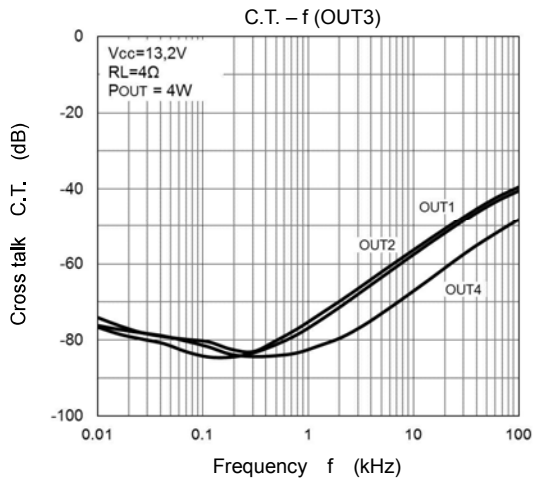
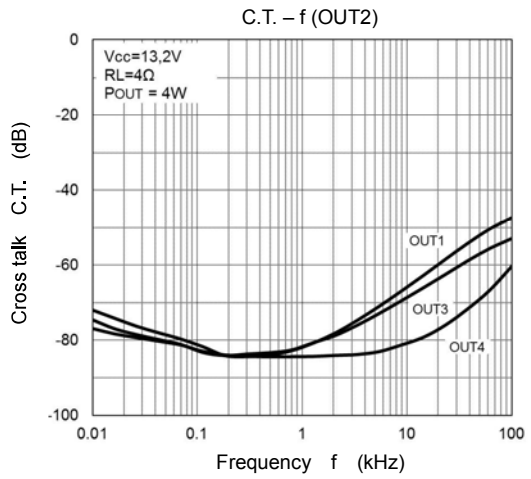
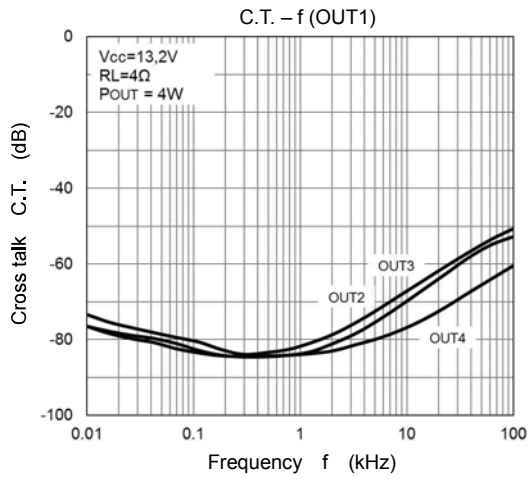
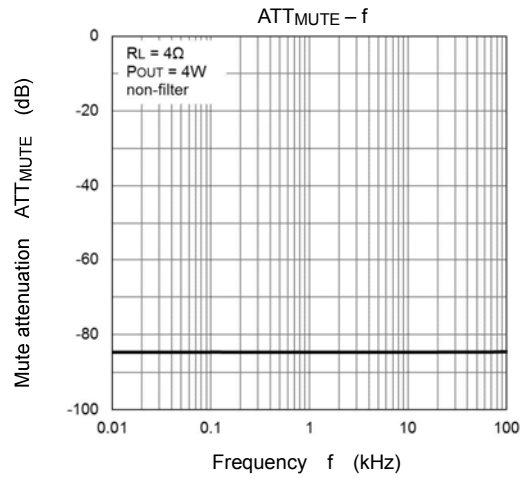
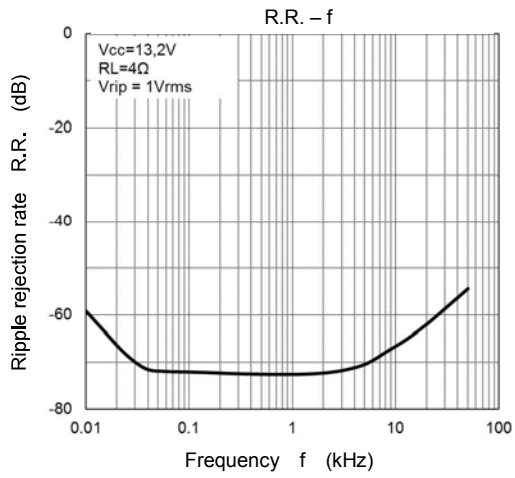

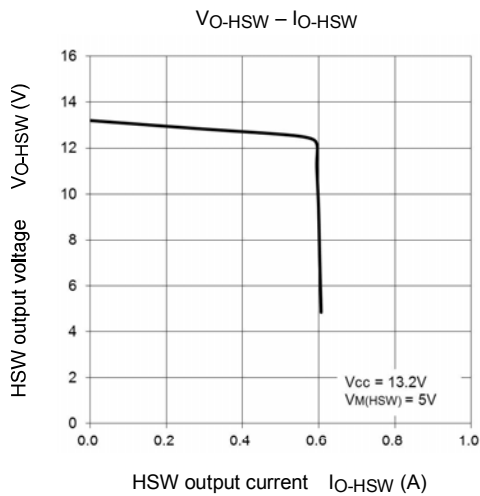
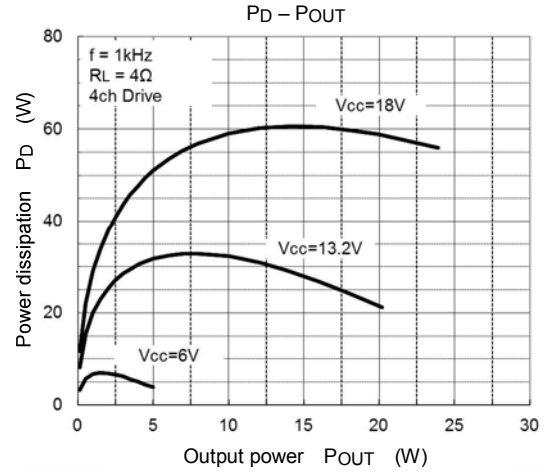
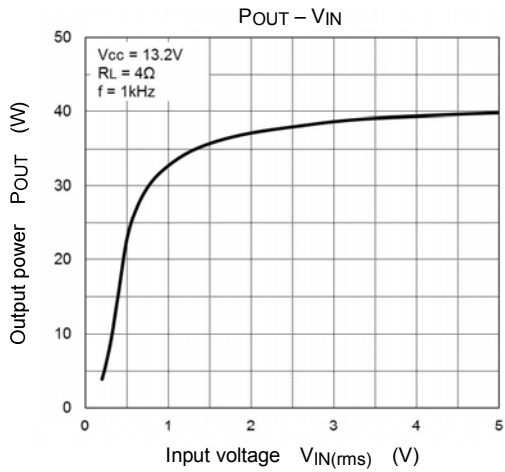
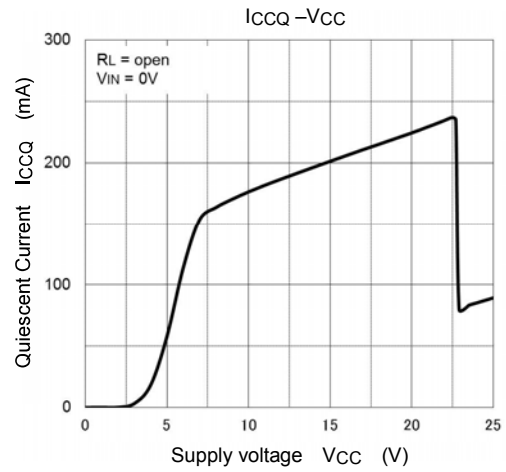
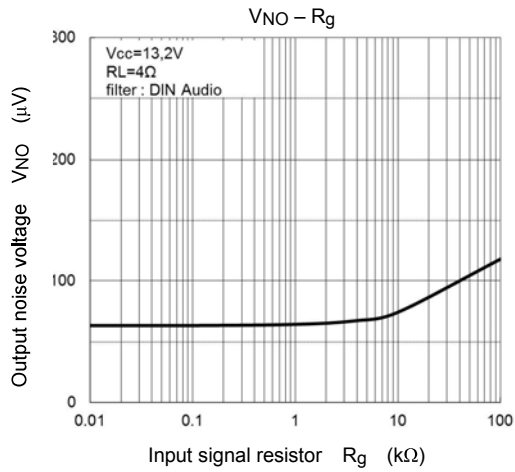

19. Package Dimensions

HZIP25-P-1.00F

Unit: mm

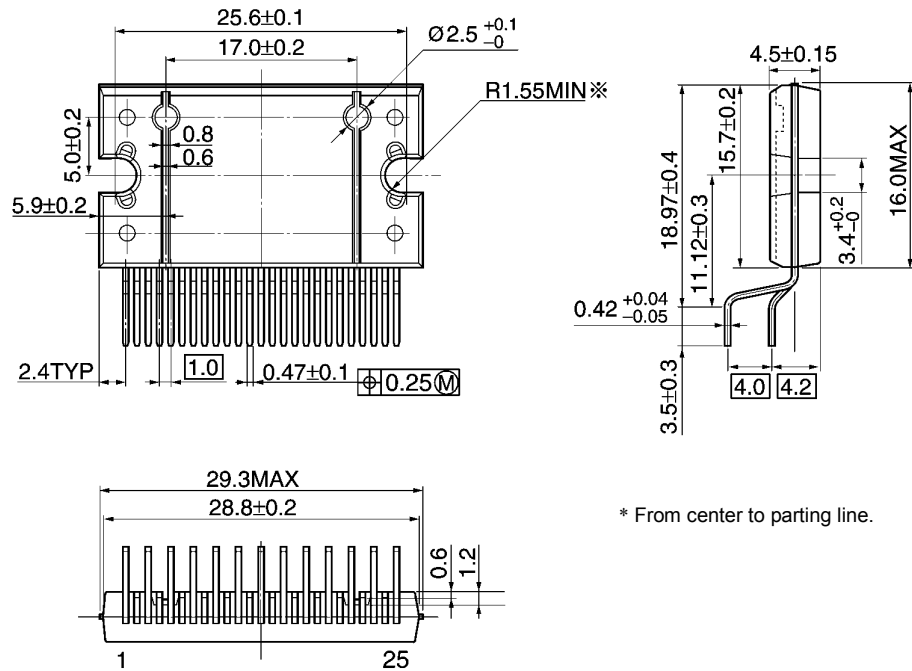

* From center to parting line.

Weight: 7.7 g (typ.)

20. Attention in Use

- Use an appropriate power supply fuse to ensure that a large current does not continuously flow in case of over current and/or IC failure. The IC will fully break down when used under conditions that exceed its absolute maximum ratings, when the wiring is routed improperly or when an abnormal pulse noise occurs from the wiring or load, causing a large current to continuously flow and the breakdown can lead smoke or ignition. To minimize the effects of the flow of a large current in case of breakdown, appropriate settings, such as fuse capacity, fusing time and insertion circuit location, are required.
- If your design includes an inductive load such as a motor coil, incorporate a protection circuit into the design to prevent device malfunction or breakdown caused by the current resulting from the inrush current at power ON or the negative current resulting from the back electromotive force at power OFF. For details on how to connect a protection circuit such as a current limiting resistor or back electromotive force adsorption diode, refer to individual IC datasheets or the IC databook. IC breakdown may cause injury, smoke or ignition.
- Use a stable power supply with ICs with built-in protection functions. If the power supply is unstable, the protection function may not operate, causing IC breakdown. IC breakdown may cause injury, smoke or ignition.
- Carefully select external components (such as inputs and negative feedback capacitors) and load components (such as speakers), for example, power amp and regulator. If there is a large amount of leakage current such as input or negative feedback condenser, the IC output DC voltage will increase. If this output voltage is connected to a speaker with low input withstand voltage, overcurrent or IC failure can cause smoke or ignition. (The over current can cause smoke or ignition from the IC itself.) In particular, please pay attention when using a Bridge Tied Load (BTL) connection type IC that inputs output DC voltage to a speaker directly.
- Over current Protection Circuit
Over current protection circuits (referred to as current limiter circuits) do not necessarily protect ICs under all circumstances. If the Over current protection circuits operate against the over current, clear the over current status immediately. Depending on the method of use and usage conditions, such as exceeding absolute maximum ratings can cause the over current protection circuit to not operate properly or IC breakdown before operation. In addition, depending on the method of use and usage conditions, if over current continues to flow for a long time after operation, the IC may generate heat resulting in breakdown.
- Thermal Shutdown Circuit
Thermal shutdown circuits do not necessarily protect ICs under all circumstances. If the Thermal shutdown circuits operate against the over temperature, clear the heat generation status immediately. Depending on the method of use and usage conditions, such as exceeding absolute maximum ratings can cause the thermal shutdown circuit to not operate properly or IC breakdown before operation.
- Heat Radiation Design
When using an IC with large current flow such as power amp, regulator or driver, please design the device so that heat is appropriately radiated, not to exceed the specified junction temperature (Tj) at any time and condition. These ICs generate heat even during normal use. An inadequate IC heat radiation design can lead to decrease in IC life, deterioration of IC characteristics or IC breakdown. In addition, please design the device taking into considerate the effect of IC heat radiation with peripheral components.
- Installation to Heat Sink
Please install the power IC to the heat sink not to apply excessive mechanical stress to the IC. Excessive mechanical stress can lead to package cracks, resulting in a reduction in reliability or breakdown of internal IC chip. In addition, depending on the IC, the use of silicon rubber may be prohibited. Check whether the use of silicon rubber is prohibited for the IC you intend to use, or not. For details of power IC heat radiation design and heat sink installation, refer to individual technical datasheets or IC databooks.

RESTRICTIONS ON PRODUCT USE

- Toshiba Corporation, and its subsidiaries and affiliates (collectively "TOSHIBA"), reserve the right to make changes to the information in this document, and related hardware, software and systems (collectively "Product") without notice.
- This document and any information herein may not be reproduced without prior written permission from TOSHIBA. Even with TOSHIBA's written permission, reproduction is permissible only if reproduction is without alteration/omission.
- Though TOSHIBA works continually to improve Product's quality and reliability, Product can malfunction or fail. Customers are responsible for complying with safety standards and for providing adequate designs and safeguards for their hardware, software and systems which minimize risk and avoid situations in which a malfunction or failure of Product could cause loss of human life, bodily injury or damage to property, including data loss or corruption. Before customers use the Product, create designs including the Product, or incorporate the Product into their own applications, customers must also refer to and comply with (a) the latest versions of all relevant TOSHIBA information, including without limitation, this document, the specifications, the data sheets and application notes for Product and the precautions and conditions set forth in the "TOSHIBA Semiconductor Reliability Handbook" and (b) the instructions for the application with which the Product will be used with or for. Customers are solely responsible for all aspects of their own product design or applications, including but not limited to (a) determining the appropriateness of the use of this Product in such design or applications; (b) evaluating and determining the applicability of any information contained in this document, or in charts, diagrams, programs, algorithms, sample application circuits, or any other referenced documents; and (c) validating all operating parameters for such designs and applications. **TOSHIBA ASSUMES NO LIABILITY FOR CUSTOMERS' PRODUCT DESIGN OR APPLICATIONS.**
- **PRODUCT IS NEITHER INTENDED NOR WARRANTED FOR USE IN EQUIPMENTS OR SYSTEMS THAT REQUIRE EXTRAORDINARILY HIGH LEVELS OF QUALITY AND/OR RELIABILITY, AND/OR A MALFUNCTION OR FAILURE OF WHICH MAY CAUSE LOSS OF HUMAN LIFE, BODILY INJURY, SERIOUS PROPERTY DAMAGE AND/OR SERIOUS PUBLIC IMPACT ("UNINTENDED USE").** Except for specific applications as expressly stated in this document, Unintended Use includes, without limitation, equipment used in nuclear facilities, equipment used in the aerospace industry, medical equipment, equipment used for automobiles, trains, ships and other transportation, traffic signaling equipment, equipment used to control combustions or explosions, safety devices, elevators and escalators, devices related to electric power, and equipment used in finance-related fields. **IF YOU USE PRODUCT FOR UNINTENDED USE, TOSHIBA ASSUMES NO LIABILITY FOR PRODUCT.** For details, please contact your TOSHIBA sales representative.
- Do not disassemble, analyze, reverse-engineer, alter, modify, translate or copy Product, whether in whole or in part.
- Product shall not be used for or incorporated into any products or systems whose manufacture, use, or sale is prohibited under any applicable laws or regulations.
- The information contained herein is presented only as guidance for Product use. No responsibility is assumed by TOSHIBA for any infringement of patents or any other intellectual property rights of third parties that may result from the use of Product. No license to any intellectual property right is granted by this document, whether express or implied, by estoppel or otherwise.
- **ABSENT A WRITTEN SIGNED AGREEMENT, EXCEPT AS PROVIDED IN THE RELEVANT TERMS AND CONDITIONS OF SALE FOR PRODUCT, AND TO THE MAXIMUM EXTENT ALLOWABLE BY LAW, TOSHIBA (1) ASSUMES NO LIABILITY WHATSOEVER, INCLUDING WITHOUT LIMITATION, INDIRECT, CONSEQUENTIAL, SPECIAL, OR INCIDENTAL DAMAGES OR LOSS, INCLUDING WITHOUT LIMITATION, LOSS OF PROFITS, LOSS OF OPPORTUNITIES, BUSINESS INTERRUPTION AND LOSS OF DATA, AND (2) DISCLAIMS ANY AND ALL EXPRESS OR IMPLIED WARRANTIES AND CONDITIONS RELATED TO SALE, USE OF PRODUCT, OR INFORMATION, INCLUDING WARRANTIES OR CONDITIONS OF MERCHANTABILITY, FITNESS FOR A PARTICULAR PURPOSE, ACCURACY OF INFORMATION, OR NONINFRINGEMENT.**
- Do not use or otherwise make available Product or related software or technology for any military purposes, including without limitation, for the design, development, use, stockpiling or manufacturing of nuclear, chemical, or biological weapons or missile technology products (mass destruction weapons). Product and related software and technology may be controlled under the applicable export laws and regulations including, without limitation, the Japanese Foreign Exchange and Foreign Trade Law and the U.S. Export Administration Regulations. Export and re-export of Product or related software or technology are strictly prohibited except in compliance with all applicable export laws and regulations.
- Please contact your TOSHIBA sales representative for details as to environmental matters such as the RoHS compatibility of Product. Please use Product in compliance with all applicable laws and regulations that regulate the inclusion or use of controlled substances, including without limitation, the EU RoHS Directive. **TOSHIBA ASSUMES NO LIABILITY FOR DAMAGES OR LOSSES OCCURRING AS A RESULT OF NONCOMPLIANCE WITH APPLICABLE LAWS AND REGULATIONS.**