

THIS COPY IS PROVIDED ON A RESTRICTED BASIS AND IS NOT TO BE USED IN ANY WAY DETRIMENTAL TO THE INTERESTS OF PANDUIT CORP.

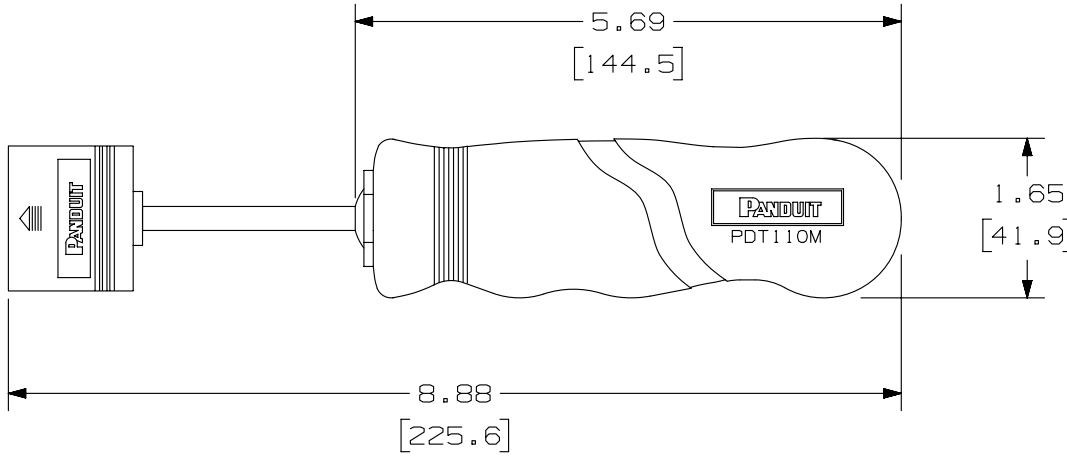

IMPACT TERMINATION TOOL  
PDT110M

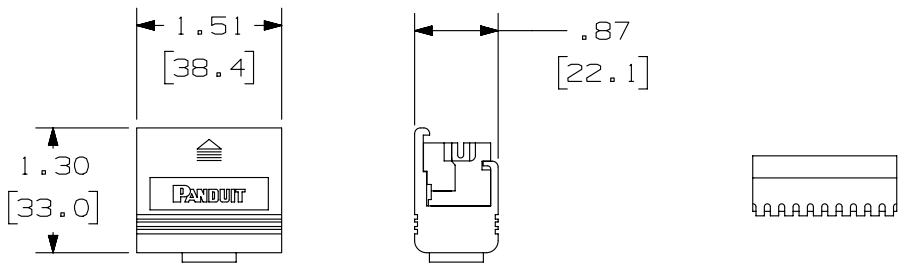

TERMINATION HEAD HOUSING ALUMINUM  
PDH110M

CUTTING BLADE  
PDB110M

PANDUIT PART NO.	WEIGHT
PDT110M	1.01 LB/ea 458.14 g/ea
PDB110M	.013 LB/ea 5.95 g/ea
PDH110M	.126 LB/ea 56.95 g/ea

- NOTES:
- SEE CURRENT CATALOG FOR ADDITIONAL PART NUMBER SUFFIXES TO INDICATE PACKAGE QUANTITY.
  - PARTS INCLUDED ARE:  
PDT110M 5 PAIR MULTIPLE PUNCHDOWN TOOL (INCLUDES ALL COMPONENTS OF PDH110M)  
PDB110M REPLACEMENT CUTTING BLADE.  
PDH110M HEAD FOR IMPACT TERMINATION TOOL CUTTING BLADE AND INSERTION ASSEMBLY.
  - DIMENSIONS IN [ ] ARE IN METRIC.
  - TERMINATES CABLE ON BOTH CABLE AND CROSSCONNECT SIDES OF 110 CONNECTING BLOCKS. REVERSIBLE BLADE PROVIDES OPTION OF TERMINATING WITHOUT CUTTING WIRE. SEATS 3, 4, OR 5 PAIR CONNECTING BLOCKS ONTO 110 BASE.

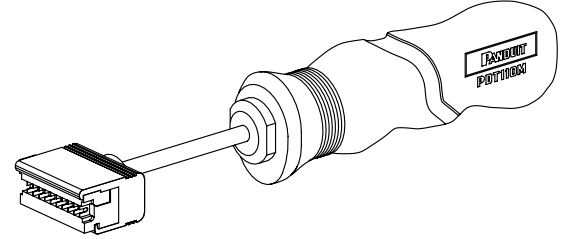

PART NUMBER PDT110M, PDB110M, PDH110M					
TITLE PAN-PUNCH 110 STYLE MULTI-PAIR PUNCH DOWN TOOL					
CUSTOMER DRAWING					
ITEM REVISION NAME D35543BZ/00	<b>PANDUIT</b>				
DATASET FILE NAME D35543BZ_DC_PDT110M/00A					
UNLESS OTHERWISE SPECIFIED, DIMENSIONAL TOLERANCES ARE: IN [mm]					
<table border="0"> <tr> <td>.x ±</td> <td>.xxx ± .010 [ .3 ]</td> </tr> <tr> <td>.xx ± .03 [ .8 ]</td> <td>ANGLES ±</td> </tr> </table>		.x ±	.xxx ± .010 [ .3 ]	.xx ± .03 [ .8 ]	ANGLES ±
.x ±	.xxx ± .010 [ .3 ]				
.xx ± .03 [ .8 ]	ANGLES ±				
THIRD ANGLE PROJECTION					
DRAWN BY BAP	DATE 2-5-97				
CHK CAF	SCALE NONE				
DRAWING NUMBER: 35543-24					
SHT 1 OF 1					
SIZE A					

REV	DATE	BY	CHK	APR	DESCRIPTION	ECN
1	5/20/14	JSP	REFR	MMR	A. REVISED DRAWING TITLE BLOCK	35543-24
R	2-5-97	BAP	CAF	CAF	RELEASED TO PRODUCTION	35543-24

D10100DA/14