

# 1200V HighSpeed 3 IGBT in TO-247PLUS Evaluation Board

## User Manual

### About this document

#### Scope and purpose

This application note is a user guide for the 1200V HighSpeed 3 IGBT in TO-247PLUS evaluation board. It explains the board's hardware and provides detailed instructions on how to use it for addressing various measurement tasks. Finally, practical examples demonstrate the benefits of both, TO-247PLUS and TO-247PLUS 4pin packages.

#### Intended audience

This document is intended for owners and users of the evaluation board.

### Table of Contents

<b>About this document</b> .....	<b>1</b>
<b>Table of Contents</b> .....	<b>1</b>
<b>1 Introduction</b> .....	<b>3</b>
1.1 Purpose of the board.....	3
1.2 Scope of delivery.....	4
<b>2 Hardware</b> .....	<b>5</b>
2.1 Circuit and main components.....	5
2.2 Recommended accessories.....	6
<b>3 Usage</b> .....	<b>8</b>
3.1 Settings.....	8
3.1.1 Replacing switches or diodes.....	8
3.1.2 Changing between 3pin and 4pin packages.....	9
3.1.3 Tuning gate voltages and resistors.....	10
3.1.4 Adjusting and monitoring the heat sink temperature.....	11
3.2 Operation.....	11
3.2.1 Configurations.....	11
3.2.2 Switching loss measurements.....	13
3.2.3 Efficiency or temperature measurements.....	14
<b>4 Examples</b> .....	<b>15</b>
4.1 Turn-on loss reduction with a 4pin package.....	15
4.2 Substituting parallel 40A devices with a 75A device.....	16
<b>5 Appendix</b> .....	<b>18</b>
5.1 Schematic drawing.....	18
5.2 Board layout.....	19
5.3 Bill of materials.....	21
<b>References</b> .....	<b>24</b>
<b>Revision History</b> .....	<b>25</b>

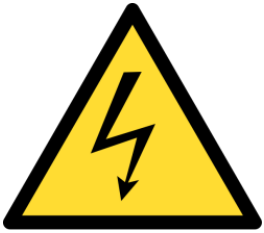

**Dangerous Equipment!**

**High Voltage**

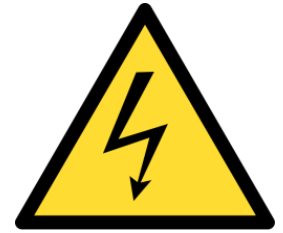

**Do NOT touch the board during operation.**

Depending on the configuration of the board and the chosen supply-voltage, life-threatening voltages might be present!

**Even brief accidental contact during operation might result in severe injury or death!**

Always make sure that the capacitors are discharged before touching the board.

**Only qualified personnel are allowed to handle this board!**

Read the instructions provided in this application note before putting the evaluation board into operation

The board described is an evaluation board dedicated for laboratory environment only. It operates at high voltages and must only be operated by qualified and skilled personnel familiar with all applicable safety standards.

### Introduction

## 1 Introduction

The evaluation board EVAL-IGBT-1200V-TO247PLUS was developed as a test platform for 1200V IGBTs in TO-247PLUS and TO-247PLUS 4pin packages but can also be used for standard TO-247 and TO-247 4pin packages.

This introductory section provides an overview of the potential applications of the evaluation board and lists the components included in the delivery.

### 1.1 Purpose of the board

The main motivation to develop the evaluation board shown in Figure 1 was to have one universal test platform for 1200V IGBTs in TO-247 as well as TO-247PLUS packages with three as well as four leads. It allows evaluating the advantages provided by the larger lead frame area of the TO-247PLUS package as well as the performance improvement given by the Kelvin emitter connection of the TO-247PLUS 4pin package. For detailed information on these packages refer to application notes [1] and [2], respectively.

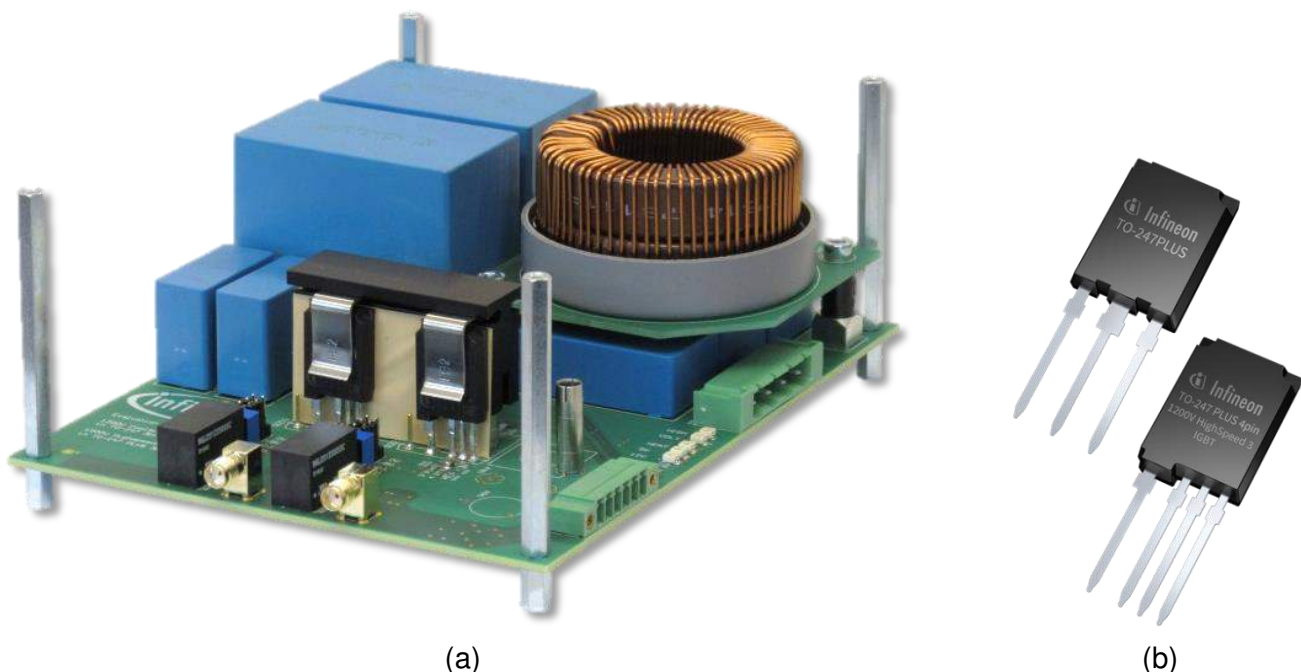

**Figure 1 Evaluation board and devices under test: (a) 1200V HighSpeed 3 IGBT in TO-247PLUS Evaluation Board, (b) TO-247PLUS and TO-247PLUS 4pin package**

Two different modes of operation can be implemented with this board. First, it can be used to investigate the switching behavior and measure the switching losses of IGBTs and diodes at different conditions. Parameters like the DC link voltage, the load current, the device temperature as well as the gate voltages and resistors are easily adjustable. If desired, snubbers can be assembled as well. Second, the board can be operated as a step-up or step-down DC/DC converter. Thus, it is possible to characterize and run devices in a continuous mode of operation in the same setup.

Care was taken to minimize the parasitic inductances and capacitances of this board wherever possible. If needed, board users can tune the parasitic circuit elements by simply adding small capacitances and inductances.

## Introduction

### 1.2 Scope of delivery

The evaluation board is delivered together with spare parts and complete documentation in an environmentally friendly carton box as illustrated in Figure 2. As depicted, the carton box contains:

- Evaluation board EVAL-IGBT-1200V-TO247PLUS with a size of 172mm x 133mm x 72mm (LxWxH)
- 1200V HighSpeed 3 IGBTs IKQ50N120CH3, IKQ75N120CH3, IKY50N120CH3 and IKY75N120CH3
- 1ED Compact isolated gate-driver ICs 1EDI60I12AH in a 300mil wide-body package
- USB flash drive containing all related application notes and data sheets
- Wire-to-board plugs for connecting the evaluation board to sources and loads



**Figure 2 Scope of delivery: evaluation board, spare parts and USB drive with documentation**

For high accuracy switching loss measurements, it is highly recommended to use these additional components which are not included in the delivery:

- Coaxial shunt SDN-414-xxx (IB Billmann) for high accuracy current measurements
- Probe adapter A-PCB-5,0-L (PMK) for connecting a passive high voltage oscilloscope probe
- Probe adapters PK106-4 (LeCroy) for connecting passive low voltage oscilloscope probes

## 2 Hardware

This section provides a short description of the board hardware. First, it explains the power circuitry, the main components and the connectors. Then, the application of the recommended accessories is discussed.

### 2.1 Circuit and main components

As shown in the block diagram of Figure 3, the evaluation board essentially is a half bridge converter consisting of two IGBTs,  $S_1$  and  $S_2$ . Due to the clip-based heat sink mounting and the universal socket on the PCB it is possible to assemble standard TO-247 and TO-247PLUS packages with three as well as four leads.

The switches are driven using EiceDriver™ 1ED Compact driver ICs. Due to the robust nature of the coreless transformer technology combined with the 300mil wide-body package, these drivers are well suited for applications that require high voltages, frequencies and switching speeds. Both drivers are controlled with independent PWM signals on the connectors SIG-HS and SIG-LS. The driving voltages are provided using the 12V auxiliary supply and isolated DC/DC converters.

For versatility reasons, the evaluation board was equipped with input and output capacitors  $C_{in}$  and  $C_{out}$  as well as a load inductor  $L$ . While the input capacitor and the load inductor were designed having mainly switching loss measurements in mind, the output capacitor is required for continuous operation, for instance as a buck converter. The provided filter inductor might not meet the requirements for the latter case but it is straightforward to replace it with a custom solution.

The same applies to the heat sink: its size and shape reveals that it cannot provide the cooling performance required for continuous operation. Rather, it is intended to serve as a heating element for performing high temperature switching loss measurements. Using the power resistor  $R_{POW}$  and the thermistor  $R_{NTC}$ , the heat sink temperature can be adjusted and monitored, respectively. Again, it is easily possible to replace the provided heat sink with a high performance solution.

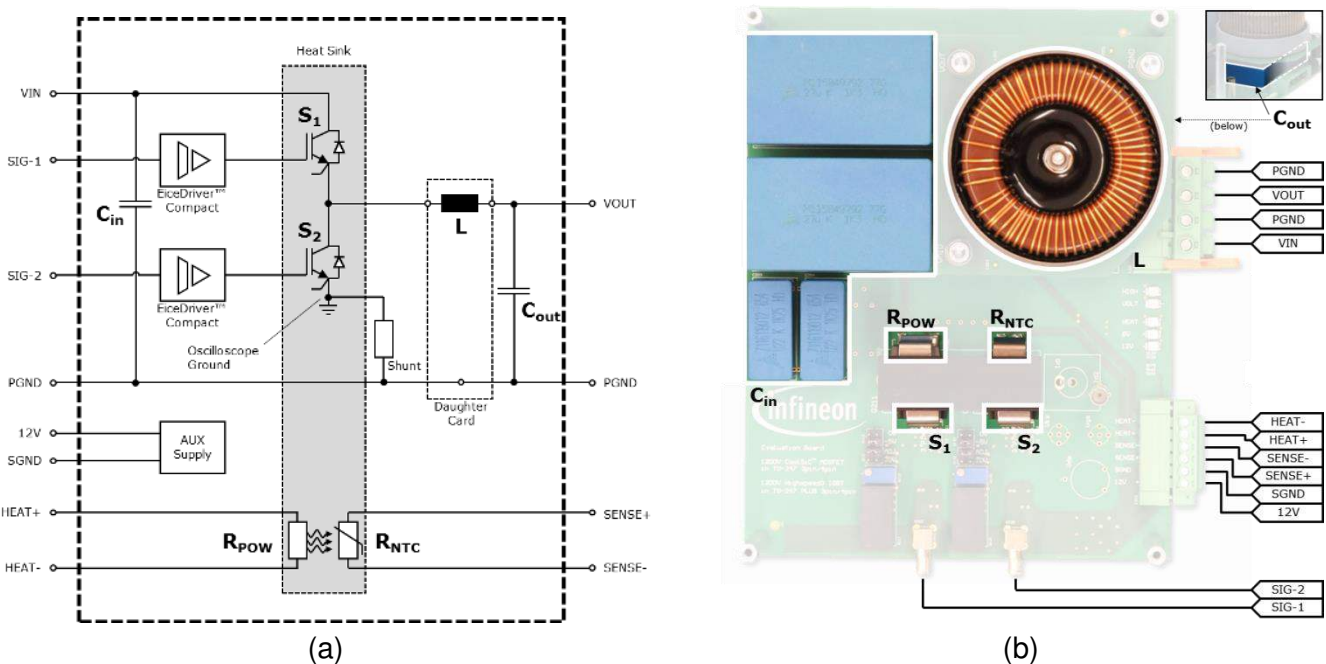

Figure 3 Overview of the board schematics (a) and components (b)

### Hardware

An experimental analysis of a device's switching behavior requires oscilloscope measurements of the gate voltage, the collector-emitter voltage as well as the collector current. While voltage measurements are straightforward, current measurements are more difficult to do, particularly in the presence of steep current slopes. This evaluation board contains a basic SMD shunt resistor solution. It gives an impression of the collector current waveform but is not considered an ideal solution for high accuracy measurements.

## 2.2 Recommended accessories

The introductory section already clarified which components are delivered with the evaluation board and which are not. Although the board can be used for switching loss measurements right away, it is strongly recommended to use additional components for the highest accuracy and signal quality.

### Coaxial shunt

Performing oscilloscope measurements of an IGBT's collector current waveform is typically a non-trivial task, particularly during switching events where extremely steep current slopes of several Amperes per nanosecond are reached. An ideal current measurement for this purpose would be non-invasive – at least it should not require significant changes of the circuit – and have a very high bandwidth.

By default, this evaluation board contains a 50mΩ metal foil SMD shunt resistor and an RC low-pass filter in order to suppress disturbances caused by parasitic circuit elements. Due to the substantial filtering, this approach might be considered a current estimation rather than a measurement. For high accuracy measurements it is recommended to use a coaxial shunt SDN-414-xxx.[3] It has a bandwidth in the gigahertz range and can be connected to any oscilloscope with a standard BNC cable.

To assemble the coaxial shunt:

1. Unsolder the 50mΩ metal foil resistor R201 and the 100Ω thin film resistor R200 on the bottom side of the board.
2. Optionally, remove the capacitor C201 and the probe adapter Id2 as they are inoperable.
3. Strip the isolation at the central terminal of the shunt and solder it to the PCB.

As visible in Figure 4, the shunt should be positioned as close to the PCB as possible to minimize parasitic inductances.

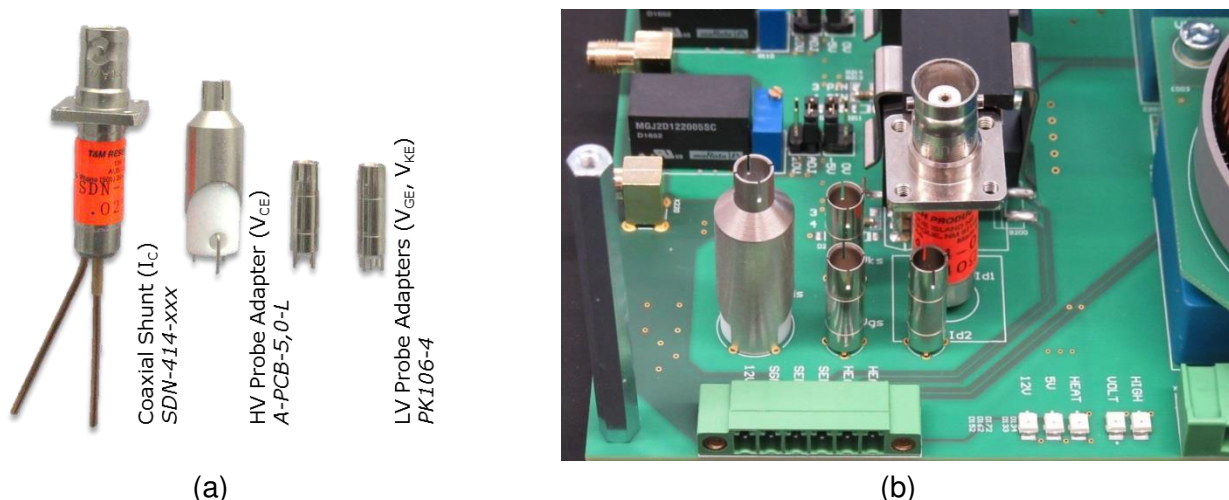

**Figure 4 Recommended accessories for switching loss measurements: (a) pictures of the components, (b) assembly of the components on the board**

Hardware

Table 1 compares waveforms as well as switching losses measured with the metal foil SMD resistor and the coaxial shunt at various temperatures and voltages. As all measurements are done with exactly the same semiconductor devices, the differences can be attributed to the different current sensors. It is clearly visible that the SMD solution estimates the basic waveform of the collector current relatively well. However, the exact determination of switching slopes and losses requires a coaxial shunt.

**Table 1 Comparison of the coaxial (black) and the SMD shunt (red) at various conditions. The double pulse tests were performed with IKY75N120CH3.**

	25°C		100°C	
	800V	400V	800V	400V
Turn-On				
Turn-Off				

Oscilloscope probe adapters

In contrast to current measurements, the acquisition of voltage waveforms is straightforward. By selecting the emitter potential of the low side IGBT S<sub>2</sub> as common ground, the gate voltage, the collector-emitter voltage and the collector current can be measured with ordinary passive probes.

While voltage probes can be connected using grounding wires and clips, the use of PCB adapters is considered advantageous for several reasons. First and foremost, the grounding of the probe is improved which leads to a proper and reproducible signal quality, especially in the presence of disturbances caused by switching transients. Additionally, connecting the probes becomes more convenient and less error-prone.

The evaluation board was designed to accommodate one PMK high voltage probe adapter A-PCB-5,0-L and two LeCroy low voltage probe adapters PK106-4 [4][5]. They share the emitter of the low-side switch as common ground and measure the voltage on the collector, on the gate and on the Kelvin connection terminal, respectively. Assembling the probe adapters can be done as depicted in Figure 4.b.

## 3 Usage

Due to its flexibility, the evaluation board can address a variety of measurement problems. While the previous sections explained the basic purpose as well as the hardware of the board, this section provides detailed instructions on how to set it up and operate it. Section 3.1 describes how to modify certain board settings, section 3.2 deals with the preparation and execution of different experiments.

### 3.1 Settings

The evaluation board is capable of testing TO-247 and TO-247PLUS packages with three as well as four leads under many different conditions. This section provides exemplary instructions on how to assemble different package variants and make the most important adjustments, particularly in the driving circuitry.

**Attention: Prevent potential exposure to hazardous voltages by turning off all power supplies and discharging the DC link capacitors before undertaking any of the modifications described in the remainder of this section.**

#### 3.1.1 Replacing switches or diodes

A PCB is subject to severe thermomechanical stress when soldering and unsoldering components. As a consequence, the adhesion between the copper layers and the core material gets weaker and eventually, copper pads or traces may lift off and break. In order to allow a large number of IGBT and diode replacements, this evaluation board uses press fit pins for connecting the TO packages and the PCB. As the device is not soldered directly to the board but to the pins, the stress to the PCB is limited.

There are several ways of removing the TO packages from the heat sink and the board. A simple approach is to cut the package leads, remove the package body from the heat sink and unsolder one lead after another from the press fit pins. Figure 5 illustrates a different strategy where the semiconductor device remains intact.

1. Put the board in an upright position so that the IGBT packages face upwards (a).
2. Push a flat screw driver between the clip and the package body and twist it to pull the clip out of the heat sink's groove (b).
3. Use two soldering irons to heat up all leads at the same time. When the solder melts on all leads, gently pull the package away from the board (c).
4. Finally, clean the press fit pins using solder wick (d).

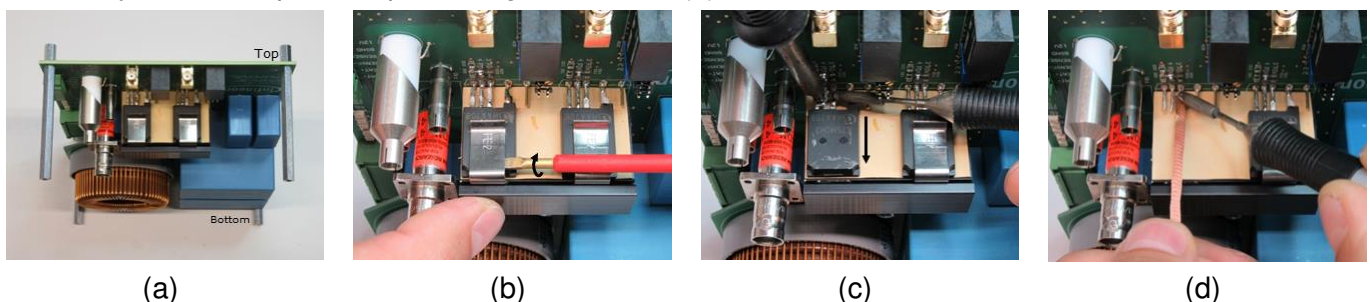

**Figure 5 Disassembling a device from the heat sink and the PCB**

The assembly of a new device is easier. Figure 6 presents a possible sequence of steps.

1. Prepare the TO package by cutting the leads to a length of around 5mm (a).
2. Place the package freely and perfectly flat on the heat sink (b).
3. Put the spring clip on the package and the heat sink groove and fasten it using pliers (c).
4. Solder one lead after the other to the press fit pins (d).



## Usage



**Figure 6** Assembling a device onto the heat sink and the PCB

### 3.1.2 Changing between 3pin and 4pin packages

Since the evaluation board has to serve as a universal test platform for TO-247-like packages with three as well as four leads, it contains special five pin sockets which can accommodate all package variants.

The connection schemes for switches and drivers are described in Table 2.

1. Solder the discrete semiconductor package to the proper socket pins: four lead packages to pins 2-5, three lead packages to pins 1-3.
2. Ensure that the reference of the driver output is connected to the proper Emitter lead using a 0Ω resistor: assemble R214/R224 for a three-pin, R213/R223 for a four pin configuration.

**Table 2** Assembly of TO-247-like packages with three and four pins

Package	TO-247 4pin TO-247PLUS 4pin		TO-247 TO-247PLUS	
Connected press fit pins	Pins 2-5		Pins 1-3	
Reference of driver output	Pin 3 (0Ω resistor at R2_4)	Pin 4 (0Ω resistor at R2_3)	Pin 3 (0Ω resistor at R2_4)	Pin 4 (0Ω resistor at R2_3)
Connection Scheme	<p>Reference of driver output (0Ω resistor at R214/ R224)</p>	<p>Reference of driver output (0Ω resistor at R213/R223)</p>	<p>Reference of driver output (0Ω resistor at R214/R224)</p>	<p>Reference of driver output (0Ω resistor at R213/R223)</p>
Picture				
Comment	Operation of the 4pin package as a 3pin package	Intended operation of the 4pin package	Intended operation of the 3pin package	<b>Attention:</b> floating gate; setting can cause device and circuit destruction

### Usage

### 3.1.3 Tuning gate voltages and resistors

Figure 7.a illustrates the schematics of the driving circuitry implemented for both, the high side and the low side switch. It includes the relevant components of the circuitry and highlights the most important part labels which consist of a letter and a three-digit number. The second digit is replaced by a wildcard underscore in the picture but would normally indicate whether the component belongs to the high side (“1”) or the low side (“2”).

A galvanically isolated EiceDriver™ 1ED Compact IC with a nominal current of 6A, separate source and sink outputs and a wide-body package forms the core of the driving circuitry. The input or primary side of the driver is powered with a voltage of 5V referring to SGND – this voltage is generated based on the 12V auxiliary input using a linear regulator – and controlled with a PWM signal on the input Sig-X. Please note that since the driver already contains high accuracy input filters, there is no need to use an external RC low-pass on the signal path. Such a filter would require additional components, introduces a higher propagation delay tolerance and is thus not recommended.

The driving voltages on the output or secondary side of the driver are provided by an isolated DC/DC converter and adjusted using the jumpers X1\_1, X1\_2 as well as the potentiometer R1\_0. These components are assembled on the top side of the board and highlighted in Figure 7.b.

To adjust the gate voltages levels:

1. Set the jumper X1\_1 to ADJ and tune the potentiometer with a flat screw driver until the recommended value of 15V is reached.
2. Select a turn-off voltage of either -5V or 0V using the jumper X1\_2.
3. Monitor or check the gate voltage levels on an oscilloscope or multimeter.

Separate turn-on and –off resistors R2\_1 and R2\_2 are assembled on the bottom side of the board. As depicted in Figure 7.c, resistors in a Mini-MELF mounting form were selected and highlighted with the labels ON and OFF. The gate resistance values can be adapted using a soldering iron.

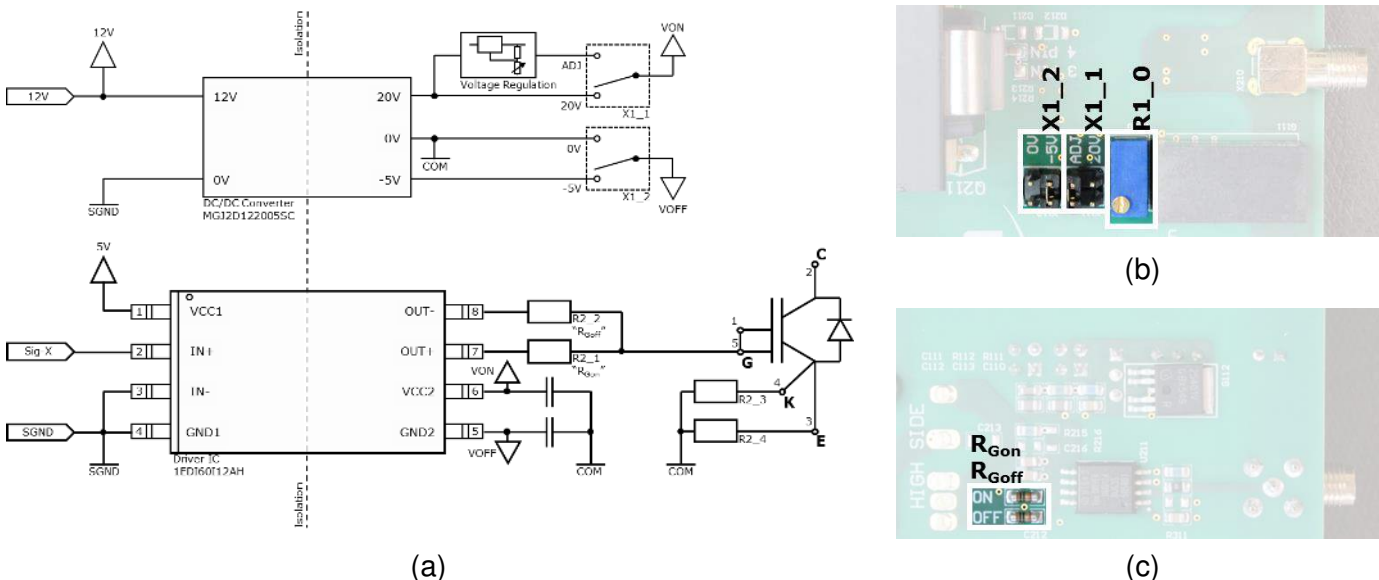

**Figure 7 Explanation of the driving settings: (a) schematics of the driving circuitry, (b) gate voltage settings, (c) gate resistors**

Usage

### 3.1.4 Adjusting and monitoring the heat sink temperature

Switching losses are not only measured at room temperature but also at temperatures of 100°C and above. Consequently, a measurement setup must offer the possibility to adjust and monitor the case temperature of the devices under test.

This evaluation board contains a small heat sink that has been designed to serve as a small heating element. The temperature of this element can be set and measured using the power resistor E200 and the NTC B200, respectively. Both devices are assembled on the back of the heat sink, on the opposite side of the devices under test.

In order to adjust the heat sink temperature:

1. Connect a laboratory power supply to the HEAT+/HEAT- terminals of the power resistor.
2. Connect an ohmmeter to the SENSE+/SENSE- terminals of the NTC thermistor.
3. Use the power supply to adjust the heat sink temperature. A rough guide is provided by Figure 8.a.
4. Monitor the actual temperature value using the ohmmeter and the NTC characteristic in Figure 8.b.

The heat sink behavior can be approximated with a thermal resistance of around 6 K/W to the ambient and a thermal time constant of approximately 7 minutes. This analytic description is valid if the heat sink is facing upwards and not exposed to a forced air cooling.

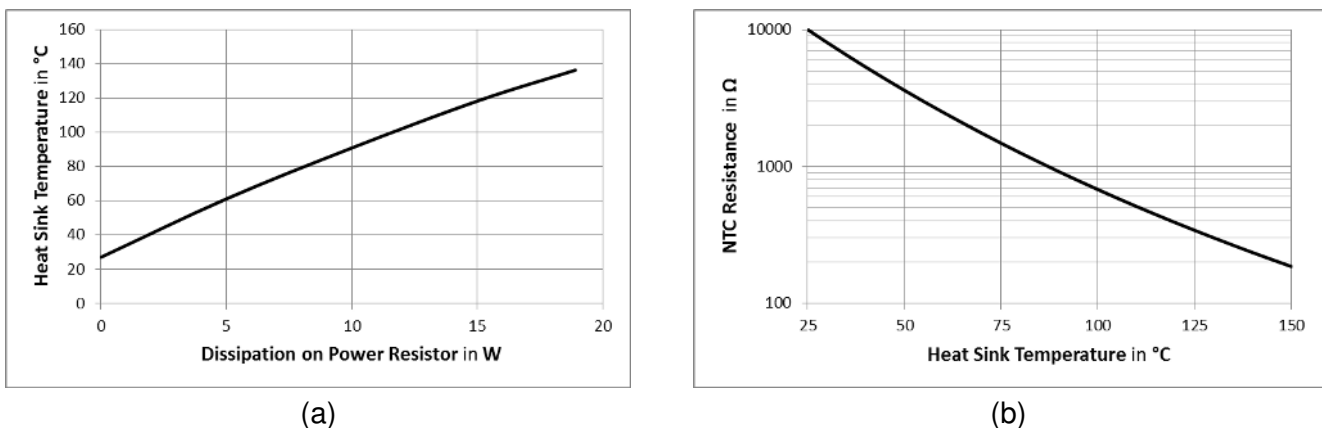

**Figure 8 Characteristics for temperature adjustments: (a) heat sink temperature as a function of power, (b) NTC value as a function of the heat sink temperature**

## 3.2 Operation

As described in section 2.1 the evaluation board implements a half bridge circuit with independent driver stages for the high side and the low side semiconductor device. Due to the universal nature of this topology, the board can be operated in various modes of operation. The remainder of this section explains the possible measurement configurations and procedures.

**Attention: Prior to starting measurements ensure that the board settings are correct. Take special care that no physical short circuits or floating gates are present. Increase the input voltages slowly and monitor that the circuit behaves as expected.**

### 3.2.1 Configurations

Table 3 provides a summary of the main board configurations. The first two lines illustrate how to study the switching behavior of a certain IGBT and diode combination. By switching the IGBT according to a double pulse signal it is possible to generate a turn-off as well as a turn-on event with a specific voltage

### Usage

and current. Measuring the current and voltage waveforms of the devices on the oscilloscope gives an impression of the switching behavior and allows a calculation of the switching losses. In order to maximize the accuracy and minimize the effort, it is recommended to make oscilloscope measurements on the low side device  $S_2$ : use configuration (1) to study the IGBT and configuration (2) to study the diode behavior. More detailed information on this mode of operation can be found in section 3.2.2.

Configuration (3) and (4) correspond to a buck and a boost converter, respectively. Since these configurations are actually processing power in a continuous manner, both the heat sink and the inductor need to meet the individual voltage, power and switching frequency requirements. It is straightforward to replace those components with appropriate custom solutions. Refer to section 3.2.3 for more detailed information on how to use the board in this mode of operation.

**Table 3 Board configurations for switching loss measurements and continuous operation**

Conf.	DUTs	Results	Parameters and limits	Simplified circuit drawing
(1) Switching Cell (Switch characterization)	Switch S2 Diode S1	$V_{CE}$ , $I_C$ and waveforms, $V_{GE}$ , $E_{on}$ , $E_{off}$ , $Q_{rr}$ , $I_{rrm}$ , $V_{CE(peak)}$ , $dv/dt$ , $di/dt$ , ...	$V_{CE}$ < 900V <sup>1</sup> $I_C$ < 150A <sup>2</sup> $T_C$ < 150°C <sup>3</sup> $V_{GE(on)}$ 0/-5V $V_{GE(off)}$ 12- 20V $R_G$ - Package TO-247x-3/4 <sup>4</sup>	
(2) Switching Cell (Diode characterization)	Diode S2 Switch S1	$V_{CE}$ , $I_C$ and waveforms, $V_{GE}$ , $E_{rec}$ , $Q_{rr}$ , $I_{rrm}$ , $dv/dt$ , $di/dt$ , ...	$V_{CE}$ < 900V <sup>1</sup> $I_C$ < 150A <sup>2</sup> $T_C$ < 150°C <sup>3</sup> $V_{GE(on)}$ 0/-5V $V_{GE(off)}$ 12- 20V $R_G$ - Package TO-247x-3/4 <sup>4</sup>	
(3) Buck Converter	Switch S1 Diode S2	$T_{S1}$ , $T_{S2}$ , $T_{heatsink}$ , $\eta$ , $V_{CE}$ and waveforms, ...	$V_{DC}$ < 900V <sup>1</sup> $f_{sw}$ - $P_{out}$ - <sup>5</sup> $V_{GE(on)}$ 0/-5V $V_{GE(off)}$ 12- 20V $R_G$ - Package TO-247x-3/4 <sup>4</sup>	
(4) Boost Converter	Switch S2 Diode S1	$T_{S1}$ , $T_{S2}$ , $T_{heatsink}$ , $\eta$ , $V_{CE}$ and waveforms, ...	$V_{DC} / (1-d)$ < 900V <sup>1</sup> $f_{sw}$ - $P_{out}$ - <sup>5</sup> $V_{GE(on)}$ 0/-5V $V_{GE(off)}$ 12- 20V $R_G$ - Package TO-247x-3/4 <sup>4</sup>	

**Do not operate a boost converter without a load!  
Ensure that the DC link voltage does not exceed 900V!**

<sup>1</sup> Limited by the ceramic DC link capacitors C201 and C202 on the bottom side of the PCB.

<sup>2</sup> Not a hard limit due to the soft saturation behavior of the inductor core.

<sup>3</sup> Limited by the maximum temperature of the power resistor.

<sup>4</sup> TO-247x-3/4 refers to TO-247 and TO-247PLUS as well as TO-247 4pin and TO-247PLUS 4pin packages.

<sup>5</sup> Limit depends on the device selection and the cooling performance.

Usage

### 3.2.2 Switching loss measurements

Switching losses can be determined using a double pulse test. It generates both a turn-off and a turn-on event by applying two consecutive pulses on the gate of the switch – hence the expression double pulse. Due to the fact that the circuit is not operated in a continuous fashion the self-heating of the semiconductors and the inductor is negligible. This is particularly convenient since the junction temperatures of  $S_1$  and  $S_2$  correspond to the heat sink temperature and are therefore well known.

The remainder of this section describes how to perform double pulse tests based on configuration (1). It is worth noting, however, that configuration (2) is operated in an analogous manner. Figure 9.a shows the principle current and voltage waveforms of  $S_2$  during the double pulse test. Initially,  $S_2$  is blocking the full DC link voltage, thus  $V_{CE}=V_{DC}$ . At  $T_0$  the switch is turning on and the current  $I_C(t)$  rises with a rate  $V_{BUS}/L$ . When the switch is turned off at  $T_1$ , the load current commutates from  $S_2$  to the diode of  $S_1$  where it is freewheeling until  $T_2$ . Then, the switch  $S_2$  is turning on and taking over the current again. After a few microseconds  $S_2$  is turned off again. The load current is commutating to the diode one last time and slowly decaying to zero in tens or hundreds of milliseconds. Using this approach it is simple to produce defined turn-off and turn-on events at  $T_1$  and  $T_2$ , respectively: while the voltage level is set directly with the DC link voltage  $V_{DC}$  the current value is adjusted with the width of the first pulse ( $T_1-T_0$ ). Figure 9.b shows the current value as a function of the pulse width for the provided inductor and different DC link voltages.

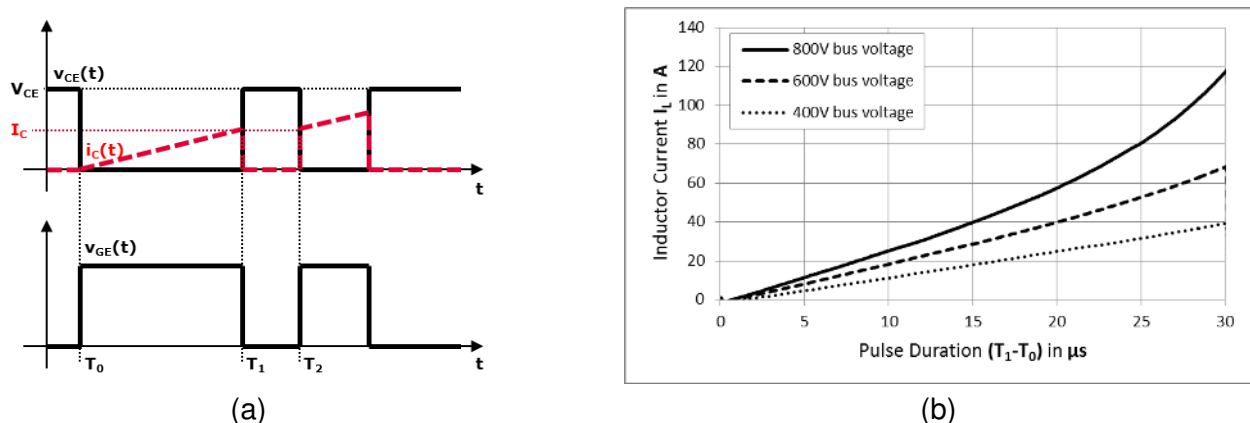

**Figure 9 Double pulse testing: (a) schematic drawing of the current and voltage waveforms during a double pulse test, (b) saturation behavior of the provided inductor**

To perform a double pulse test on the evaluation board

1. Assemble the devices under test  $S_1$  and  $S_2$  as described in section 3.1.1.
2. Connect the driver to the proper emitter pin according to section 3.1.2.
  - a) Solder  $0\Omega$  resistors to R214/R224 when using three pin packages.
  - b) Solder  $0\Omega$  resistors to R213/R223 when using four pin packages.
3. Adjust the driving circuitry for  $S_2$  and, if necessary, also for  $S_1$  according to section 3.1.3.
  - a) Set the jumper X111/X121 to ADJ.
  - b) Use the jumper X112/X122 to set the turn-off voltage to 0V or -5V.
  - c) Adjust the turn-on and turn-off gate resistors R211/R221 and R212/R222, respectively.
4. Connect oscilloscope probes in order to measure  $V_{CE}$ ,  $V_{GE}$  and  $I_C$  of  $S_2$ .
  - a) Measure  $V_{CE}$  and  $V_{GE}$  with ordinary voltage probes and grounding clips on the package. If possible use the probe adapters introduced in section 2.2.
  - b) Measure  $I_C$  using the probe adapter Id2. If possible use a coaxial shunt as recommended in 2.2.
5. Connect an auxiliary supply to the 12V/SGND terminals of the board and provide a voltage of 12V.
6. Connect a signal generator to X220 and provide a double pulse pattern with 5V amplitude. Please note that this signal is referenced to SGND.
7. Check the gate voltage waveform on the oscilloscope and adjust it according to section 3.1.3.

### Usage

8. If required, connect a power supply to the HEAT+/HEAT- terminals and set the voltage level according to 3.1.4. Monitor the temperature using an ohmmeter connected to SENSE+/SENSE-.
9. Connect a high voltage source to VIN and PGND and short VIN and VOUT.
10. Slowly increase the voltage and monitor the current and voltage waveforms on the oscilloscope.

### 3.2.3 Efficiency or temperature measurements

Testing a particular semiconductor device inside a switching cell is essential for understanding its switching behavior. However, it requires some calculation or simulation effort to translate the acquired switching loss data into quantities that are more relevant for an application, such as the efficiency of the converter, the temperature of the devices or the required cooling effort. By operating the evaluation board in a continuous manner these values can be determined in a purely experimental and thus straightforward way. The remainder of this section explains how to configure and run the board as a buck converter as sketched in configuration (3) of Table 3.

Prior to running the evaluation board as a buck converter, some preparations are required:

1. Short circuit the shunt resistor R201 in order to avoid unnecessary power dissipation.
2. Disable the LEDs that indicate the presence of the DC link voltage by removing R134, R138 and R142. Otherwise consider the power dissipation of this block: 1.6W at 800V.
3. Replace the heat sink
  - a) Unfasten the M3 screws that fix the heat sink to the board.
  - b) Pull the heat sink away from the board so that the spring clips fall off.
  - c) Unsolder the power resistor E200 and the NTC B200.
  - d) Remove the probe adapter Id2 from the board.
  - e) If necessary, solder the film capacitors C203 and C204 to the other side of the board.
  - f) Mount a reasonable heat sink. If possible put an insulation sheet between heat sink and board.
4. Replace the filter inductor
  - a) Disconnect the daughter card containing the inductor by unfastening the M4 screws.
  - b) Connect a custom inductor between the VMID and the VOUT potential.

After the preparation steps, the efficiency measurements can be performed.

1. Assemble the devices under test  $S_1$  and  $S_2$  as described in section 3.1.1.
2. Connect the driver to the proper emitter pin according to section 3.1.2.
  - a) Solder  $0\Omega$  resistors to R214/R224 when using three pin packages
  - b) Solder  $0\Omega$  resistors to R213/R223 when using four pin packages
3. Adjust the driving circuitry for  $S_1$  and, if necessary, also for  $S_2$  according to section 3.1.3.
  - a) Set the jumper X111/X121 to ADJ.
  - b) Use the jumper X112/X122 to set the turn-off voltage to 0V or -5V.
  - c) Adjust the turn-on and turn-off gate resistors R211/R221 and R212/R222, respectively.
4. Connect isolated voltage probes to measure the gate as well as the collector-emitter voltage of  $S_1$  and use a current probe to measure the inductor current.
5. Connect an auxiliary power supply to the 12V/SGND terminals of the board and provide a supply voltage of 12V.
6. Connect a signal generator to X210 and provide a PWM signal with 5V amplitude. Please note that this signal is referenced to SGND.
7. Check the gate voltage signal on the oscilloscope and adjust the turn-on voltage level to +15V using the potentiometer R110.
8. Connect a high voltage source to VIN and PGND.
9. Connect an Ohmic load to VOUT and PGND.
10. If possible, measure the input and output power using a power meter and the device temperatures using an infrared camera.
11. Slowly increase the input voltage while monitoring the waveforms and device temperatures.

Examples

## 4 Examples

After the in-depth explanation of possible test settings and procedures that were provided in the previous section, this section shows two practical examples: a switching loss and a temperature measurement.

### 4.1 Turn-on loss reduction with a 4pin package

As extensively explained in [2] on the basis of 650V TRENCHSTOP™ 5 IGBTs, the main advantage of four-pin packages over three-pin packages is the reduction of turn-on losses, particularly at higher current levels. The reason for that is the virtual elimination of the inductive coupling between the gate and the commutation loop. This section demonstrates the positive impact of the Kelvin Emitter connection, i.e. the fourth pin, on 1200V/75A HighSpeed 3 IGBTs. Table 4 summarizes the test cases.

**Table 4 Turn-on loss comparison of TO-247PLUS 3pin and 4pin: test conditions**

	Solution 1	Solution 2
Part number (IGBT and diode)	IKQ75N120CH3	IKY75N120CH3
Package	TO-247PLUS	TO-247PLUS 4pin
Junction temperature $T_j=T_c$	25°C	25°C
Switched voltage $V_{CE}$	800V	800V
Switched current $I_C$	5A-80A	5A-80A
Gate voltages $V_{GE(on)}$	+15V	+15V
Gate resistors $R_{G(on)}$	10Ω	10Ω
Driver Ground Connection	0Ω at R214 and R224	0Ω at R213 and R223

The evaluation board was set up as explained in section 3.2.2. Following the recommendations in section 2.2, current measurements were made using a coaxial shunt and voltage probes were connected via PCB adapters. Figure 10.a shows the evaluation board and the measurement hardware as the main part of the setup – power supplies and the signal generator are not included in the picture.

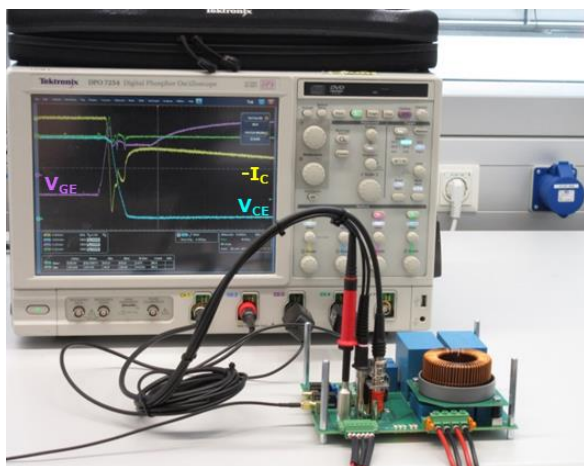

(a)

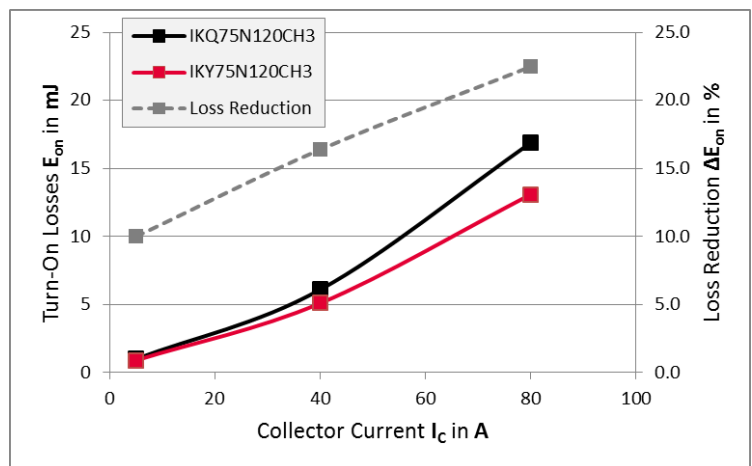

(b)

**Figure 10 Turn-on loss comparison of TO-247PLUS 3pin and 4pin: (a) main parts of the test setup, (b) absolute and relative comparison of the measured losses**

By multiplying  $V_{CE}$  and  $I_C$  on the oscilloscope the waveform of the momentary power dissipation was calculated. Integration of this power waveform resulted in the turn-on energy values  $E_{on}$  which are shown in Figure 10.b for different current levels and for both package variants. It is clearly visible that the switching losses can be significantly reduced by going to a 4pin package. Since the Kelvin Emitter is increasing  $di/dt$ , this is particularly true for higher current levels.

Examples

## 4.2 Substituting parallel 40A devices with a 75A device

With IKQ75N120CH3 and IKY75N120CH3 Infineon has pioneered assembling 1200V/75A IGBTs and full-rated diodes inside packages with a footprint of a standard TO-247. One interesting aspect of such high current ratings is the potential to limit the number of parallel devices. This section demonstrates that two parallel 40A IGBTs can be substituted by a single 75A IGBT.

*Note: Reducing the number of parallel devices by using IGBTs with higher current ratings might require a slight re-work of the isolation solution but simplifies both the power and the driving circuitry, reduces the space required on PCB and heat sink, and eliminates potential current sharing problems as well as the need for an according de-rating.*

As listed in Table 5, three boost converter solutions consisting of 1200V HighSpeed 3 IGBTs and 1200V CoolSiC™ Schottky diodes were compared. Solution 1 was considered as reference and used a 40A IGBT together with a 20A diode operating at 2kW. Both devices were assembled on the same heat sink using Kapton-based insulation sheets. Solution 2 and 3, on the other hand, consisted of 75A IGBTs and 40A diodes operating at 4kW. Thus, twice the power was processed with twice the chip size. While the latter solutions were electrically identical, they differed in the insulation: solution 2 maintained the Kapton sheets; solution 3 was equipped with an Al<sub>2</sub>O<sub>3</sub> plate for insulating the IGBT. In order to achieve comparability, care was taken to scale the semiconductor losses with the respective chip size. Besides the output power, also the switching speed and the ripple current were adjusted accordingly.

**Table 5 Comparison of the thermal performance of 40A and 75A IGBTs: test conditions**

	Solution 1	Solution 2	Solution 3
<b>Part number IGBT</b>	IKW40N120H3	IKQ75N120CH3	IKQ75N120CH3
<b>Part number diode</b>	IDW40G120C5B (1 leg)	IDW40G120C5B (2 legs)	IDW40G120C5B (2 legs)
<b>Package</b>	TO-247	TO-247PLUS	TO-247PLUS
<b>Electrical isolation (IGBT and heat sink)</b>	Insulation sheet Kapton, 1.3W/mK, 150µm	Insulation sheet Kapton, 1.3W/mK, 150µm	Ceramic plate Al <sub>2</sub> O <sub>3</sub> , 25W/mK, 1mm
<b>Thermal grease</b>	None	None	High performance: 6W/mK
<b>Heat sink assembly</b>	Clip 60N	Clip 60N	Clip 60N
<b>Gate voltages V<sub>GE</sub></b>	+15V/-5V	+15V/-5V	+15V/-5V
<b>Gate resistors R<sub>G</sub></b>	20Ω	10Ω	10Ω
<b>Topology</b>	Boost	Boost	Boost
<b>Sw. frequency f<sub>sw</sub></b>	16kHz	16kHz	16kHz
<b>Voltages V<sub>in</sub>/V<sub>out</sub></b>	400V/800V	400V/800V	400V/800V
<b>Output power P<sub>out</sub></b>	2kW	4kW	4kW
<b>Heat sink temp. T<sub>HS</sub></b>	60°C	60°C	60°C
<b>Inductance L</b>	2mH	1mH	1mH

The evaluation board was set up as explained in section 3.2.3 with one exception: a boost converter was implemented instead of a buck converter. Figure 11 shows the test setup including the custom inductor and the custom heat sink. While the inductor was handmade, a LAM 3 K miniature cooling aggregate from Fischerelektronik was used as heat sink. Since fan speed of this cooling aggregate is variable, the temperature could be adjusted to the same value during all measurements. An infrared-camera was used to monitor the heat sink and device temperatures, an oscilloscope to acquire the most relevant waveforms. Due to the boost converter configuration, the gate and collector-emitter voltage could be measured with simple passive probes. The inductor current was measured using a caliper-style current probe.



## Examples

The picture of the setup does not show the sources and loads. Besides the auxiliary supply which provides the driving voltages, a high voltage DC source and an active DC load were utilized to provide the required testing power of up to 4kW.

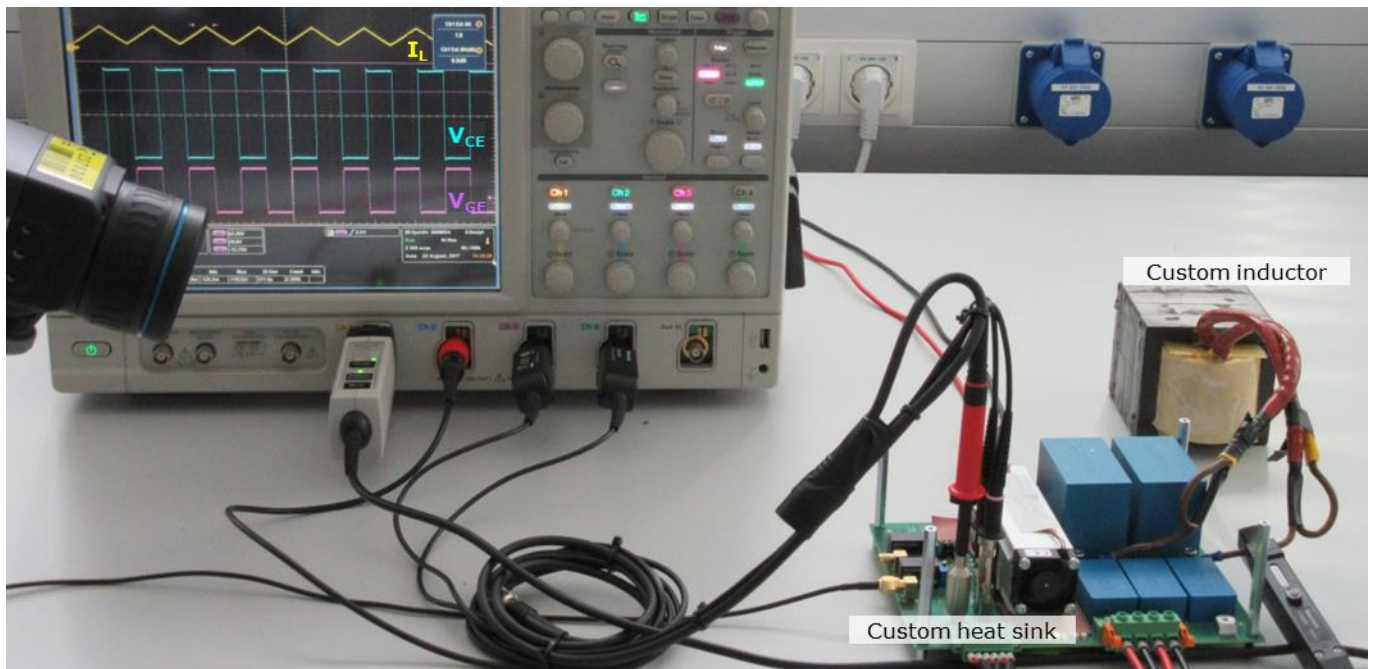

**Figure 11 Comparison of the thermal performance of 40A and 75A IGBTs: test setup**

Table 6 shows the resulting device and heat sink temperatures for all tested solutions. Please note that the scale of the IR camera is kept the same throughout all cases. Thus not only the numeric values but also the color shades are comparable.

Solution 1 is considered the reference solution because it resembles a situation with two parallel 40A IGBTs processing 4kW in total. While the test was only done with one IGBT processing 2kW one can imagine a second, parallel IGBT which processes another 2kW. Assuming perfect current sharing and a constant heat sink temperature, the temperature of the second IGBT would be equal to the one of the first.

**Table 6 Results of the temperature measurement: thermal performance of the solutions 1-3**

	Solution 1	Solution 2	Solution 3
IR camera picture (same scale for all pictures)			
IGBT temperature $T_{IGBT}$	79.4°C	98.1°C	82.8°C
Heat sink temperature $T_{HS}$	62.9°C	62.8°C	62.9°C
Temperature difference $\Delta T$	16.5°C	35.3°C	19.9°C

Comparing the IGBT temperatures of solution 1 and solution 2 indicates that replacing two parallel 40A devices with one 75A device can lead to a temperature increase if the insulation layer is kept the same. Particularly for large chips with low thermal resistance values  $R_{th(JC)}$ , the insulation sheet can become a bottleneck in terms of thermal performance. To overcome this, it is recommended to use insulators with a high thermal conductivity. One exemplary case is solution 3 where an  $Al_2O_3$  ceramic is used to bring the thermal performance of the 75A device to a level that is competitive with parallel 40A device.

## Appendix

### 5 Appendix

#### 5.1 Schematic drawing

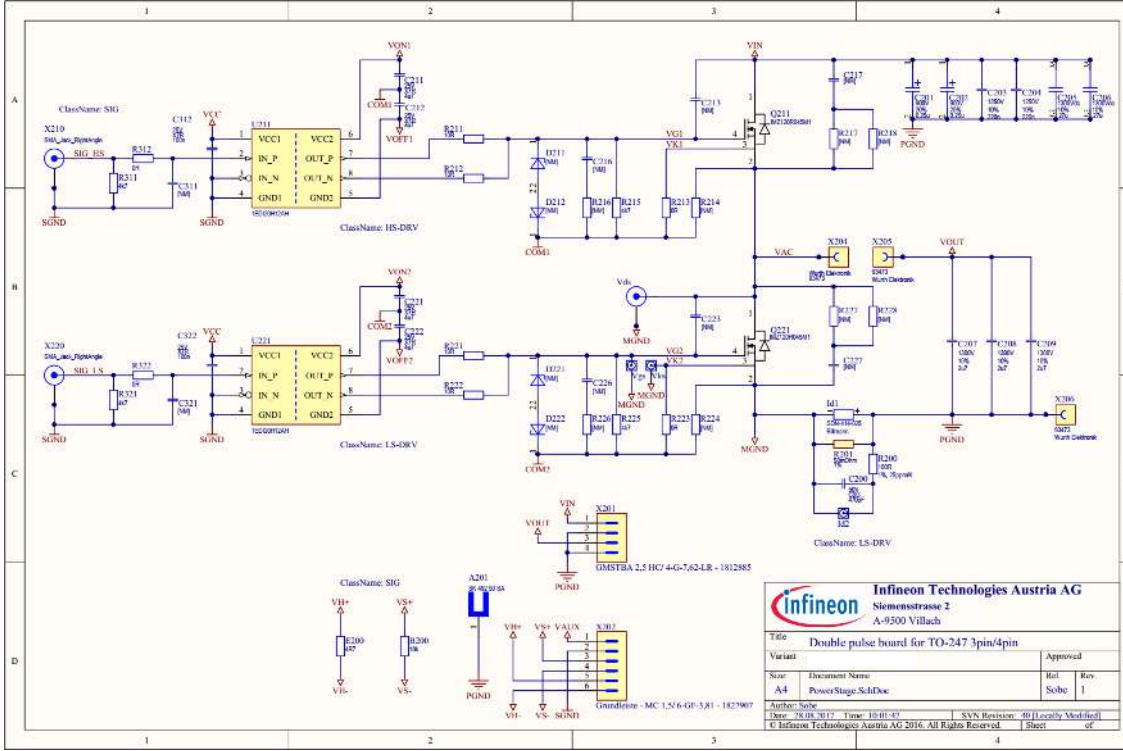

Figure 12 Power and driving circuitry

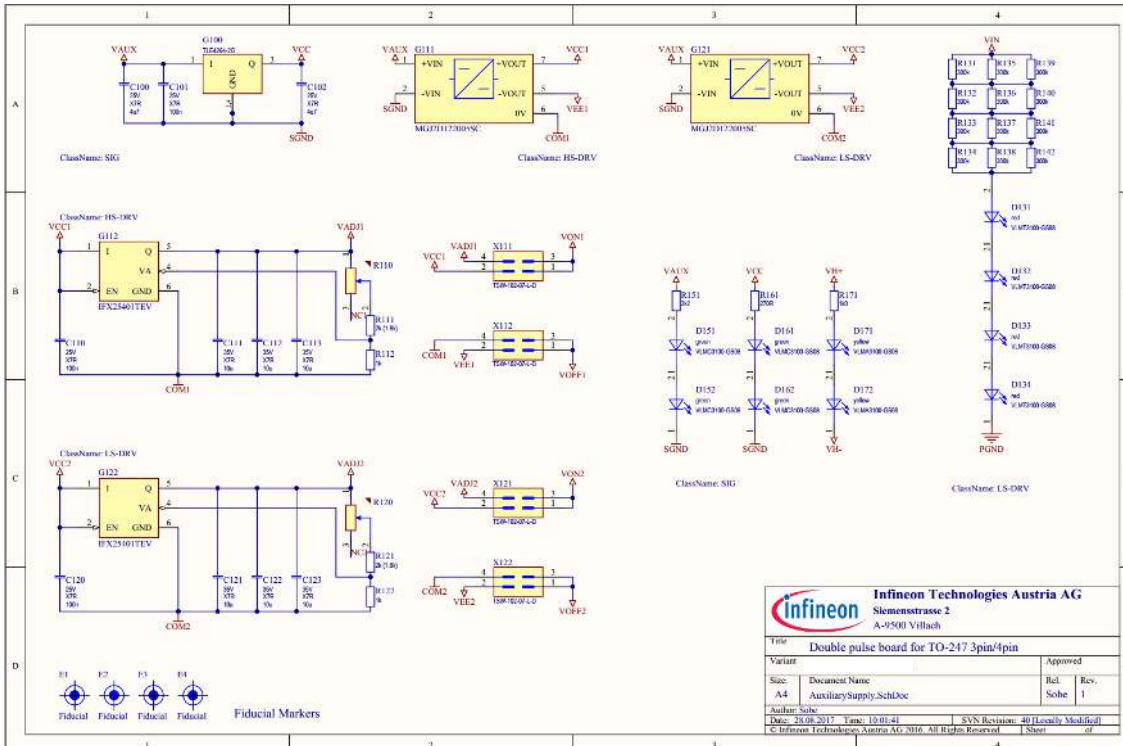

Figure 13 Auxiliary supply and LED indicators

## Appendix

### 5.2 Board layout

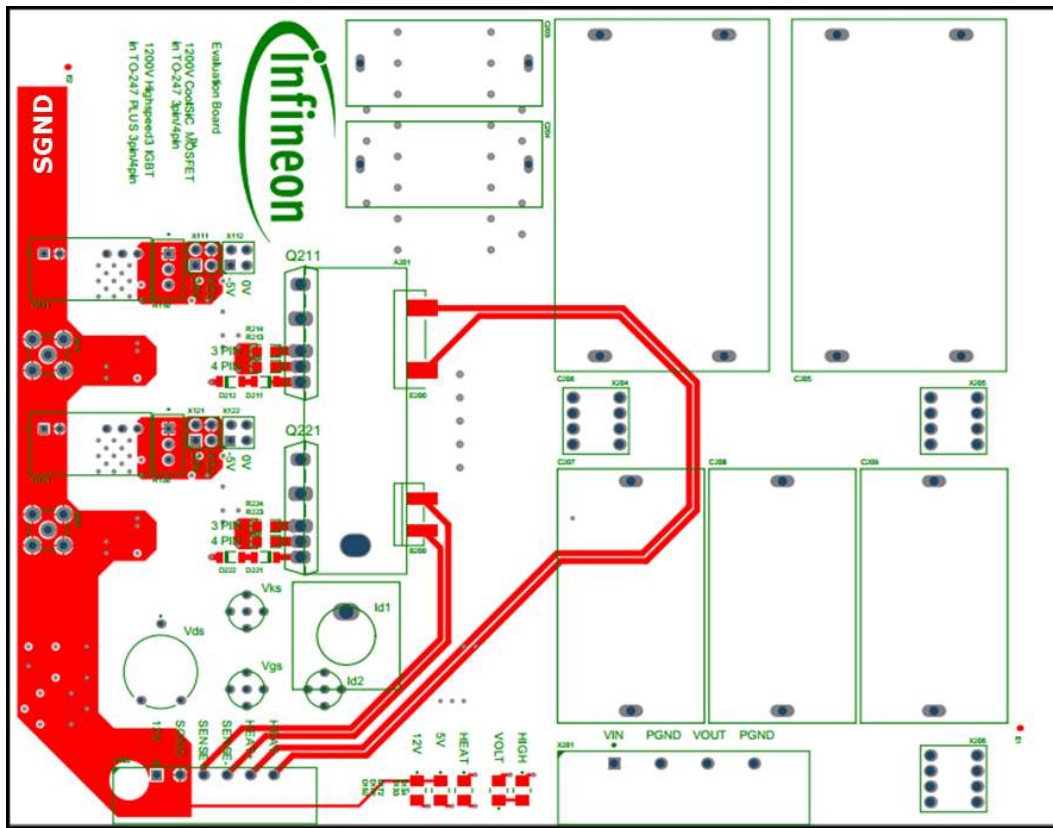

Figure 14 Layer 1 (top layer)

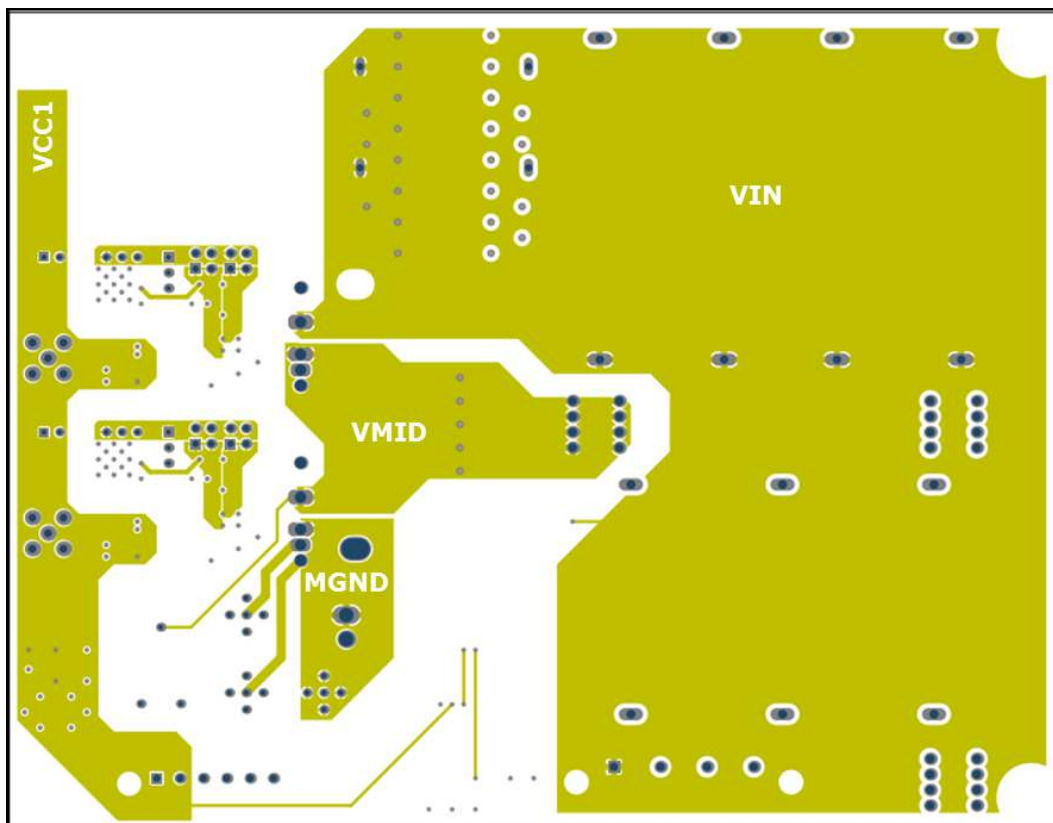

Figure 15 Layer 2

Appendix

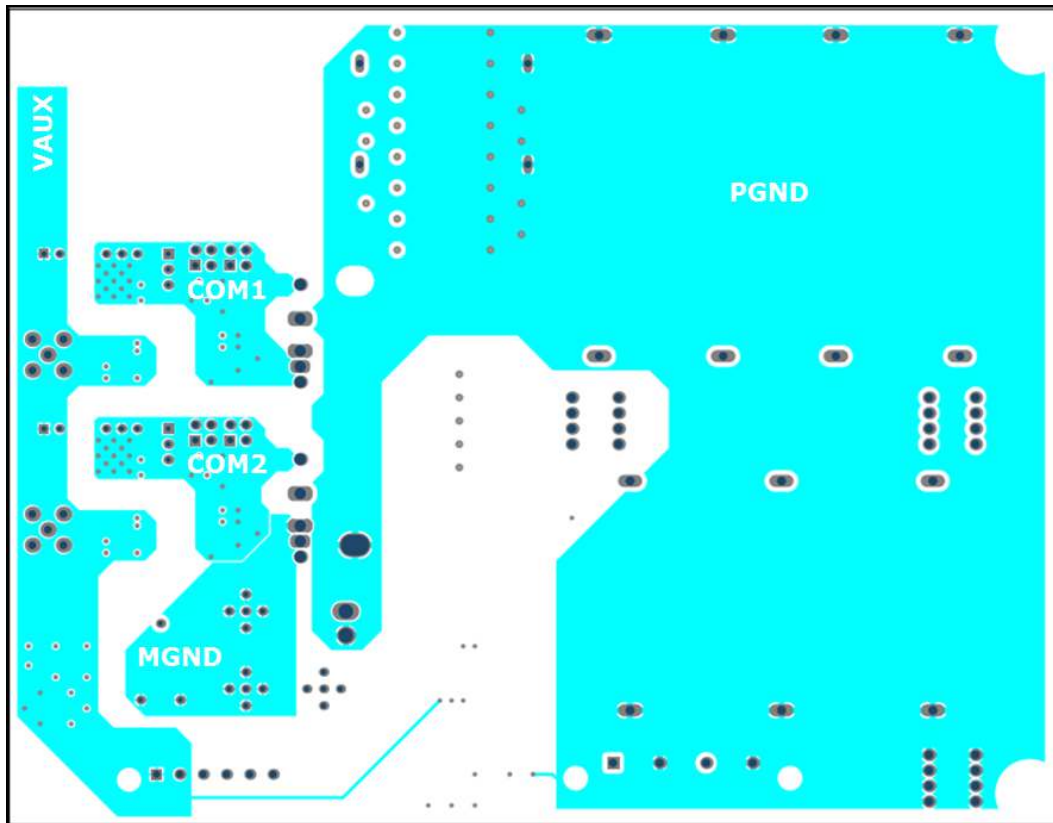

Figure 16 Layer 3

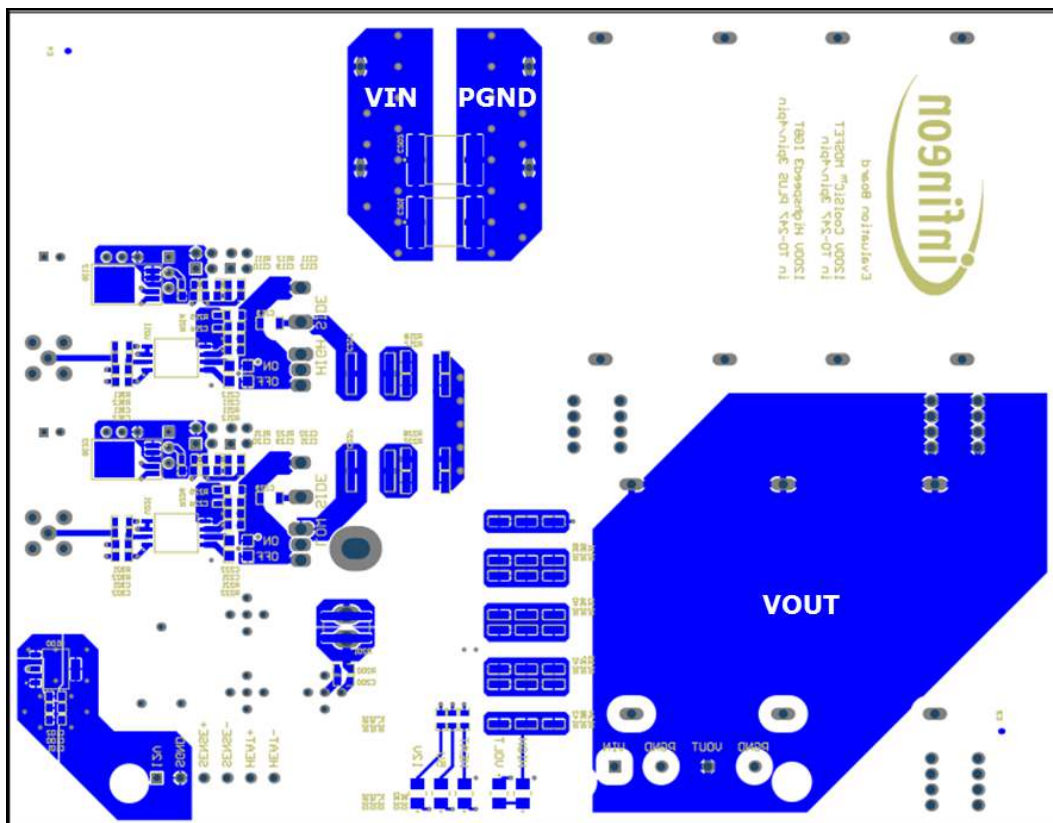

Figure 17 Layer 4 (bottom layer)

Appendix

5.3 Bill of materials

Designator	Description	Value	Package
<b>Power Semiconductors</b>			
Q211	Power Semiconductor Switch	Infineon IKY75N120CH3	TO-247PLUS 4pin
Q221	Power Semiconductor Switch	Infineon IKY75N120CH3	TO-247PLUS 4pin
U211	Isolated Single Channel Driver	Infineon Technologies 1EDI60I12AH	PG-DSO-8-59
U221	Isolated Single Channel Driver	Infineon Technologies 1EDI60I12AH	PG-DSO-8-59
<b>Ceramic Capacitors</b>			
C100		4u7 X7R 25V	C 0805
C101		100n X7R 25V	C 0805
C102		4u7 X7R 25V	C 0805
C110		100n X7R 25V	C 0805
C111		10u X7R 35V	C 0805
C112		10u X7R 35V	C 0805
C113		10u X7R 35V	C 0805
C120		100n X7R 25V	C 0805
C121		10u X7R 35V	C 0805
C122		10u X7R 35V	C 0805
C123		10u X7R 35V	C 0805
C200		470pF C0G 50V	C 0805
C201		TDK Z63000Z2910Z 1 Z21	
C202		TDK Z63000Z2910Z 1 Z21	
C211		4u7 X7R 25V	C 0805
C212		4u7 X7R 25V	C 0805
C221		4u7 X7R 25V	C 0805
C222		4u7 X7R 25V	C 0805
C312		100n X7R 25V	C 0805
C322		100n X7R 25V	C 0805
<b>Film Capacitors</b>			
C203		EPCOS TDK B32654A7224	
C204		EPCOS TDK B32654A7224	
C205		EPCOS B32778G1276	
C206		EPCOS B32778G1276	
C207		EPCOS B32776T1275	
C208		EPCOS B32776T1275	
C209		EPCOS B32776T1275	
<b>Light Emitting Diodes</b>			
D131		Vishay VLMT3100-GS08	
D132		Vishay VLMT3100-GS08	
D133		Vishay VLMT3100-GS08	
D134		Vishay VLMT3100-GS08	
D151		Vishay VLMT3100-GS08	
D152		Vishay VLMT3100-GS08	
D161		Vishay VLMT3100-GS08	
D162		Vishay VLMT3100-GS08	
D171		Vishay VLMA3100-GS08	
D172		Vishay VLMA3100-GS08	
<b>Thick Film Resistors</b>			
R111		2k (1.8k) 1%	R 0805
R112		1k 1%	R 0805
R121		2k (1.8k) 1%	R 0805
R122		1k 1%	R 0805
R131		300k	R 2512
R132		300k	R 2512
R133		300k	R 2512
R134		300k	R 2512
R135		300k	R 2512
R136		300k	R 2512

### Appendix

R137	300k	R 2512
R138	300k	R 2512
R139	300k	R 2512
R140	300k	R 2512
R141	300k	R 2512
R142	300k	R 2512
R151	2k2	R 0805
R161	270R	R 0805
R171	1k0	R 0805
R200	100R 1%, 25ppm/K	R 0805
R215	4k7	R 0805
R225	4k7	R 0805
R311	4k7	R 0805
R312	0R	R 0805
R321	4k7	R 0805
R322	0R	R 0805
<b>Metal Foil Resistors</b>		
R201	Ohmite FC5L76R050FER	
<b>MiniMELF Resistors</b>		
R211	10R 1%	R MMA 0204
R212	10R 1%	R MMA 0204
R213	0R 1%	R MMA 0204
R221	10R 1%	R MMA 0204
R222	10R 1%	R MMA 0204
R223	0R 1%	R MMA 0204
<b>Connectors</b>		
X111	Samtec TSW-102-07-L-D	
X112	Samtec TSW-102-07-L-D	
X121	Samtec TSW-102-07-L-D	
X122	Samtec TSW-102-07-L-D	
X201	Phoenix Contact 1812885	
X202	Phoenix Contact 1827907	
X204	Wurth Elektronik 93473	
X205	Wurth Elektronik 93473	
X206	Wurth Elektronik 93473	
X210	TE Connectivity 5-1814400-1	
X220	TE Connectivity 5-1814400-1	
X801	Phoenix Contact GMSTB 2,5 HCV/ 4-ST-7,62-LR - 1812775	
X802	Phoenix Contact MC 1,5/ 6-STF-3,81 - 1827745	
<b>Mechanical</b>		
A201	Heat Sink	Fischer Elektronik SK 492 50 SA
MC821	Screw	M3 x 15mm, metal
MC822	Screw	M3 x 15mm, metal
MP801	Spacer bolt, hexagon	M3 x 60mm
MP802	Spacer bolt, hexagon	M3 x 60mm
MP803	Spacer bolt, hexagon	M3 x 60mm
MP804	Spacer bolt, hexagon	M3 x 60mm
MP805	Spacer bolt, hexagon	M3 x 10mm
MP806	Spacer bolt, hexagon	M3 x 10mm
MP807	Spacer bolt, hexagon	M3 x 10mm
MP808	Spacer bolt, hexagon	M3 x 10mm
MP811	Metal tube	ETTINGER 05.53.053
MP812	Metal tube	ETTINGER 05.53.053
MP813	Metal tube	ETTINGER 05.53.053
MP814	Metal tube	ETTINGER 05.53.053
MP831	Press Fit Pin	Mill-Max 8979-0-00-15-00-00-03-0
MP832	Press Fit Pin	Mill-Max 8979-0-00-15-00-00-03-0
MP833	Press Fit Pin	Mill-Max 8979-0-00-15-00-00-03-0
MP834	Press Fit Pin	Mill-Max 8979-0-00-15-00-00-03-0

## Appendix

MP835	Press Fit Pin	Mill-Max 8979-0-00-15-00-00-03-0
MP836	Press Fit Pin	Mill-Max 8979-0-00-15-00-00-03-0
MP837	Press Fit Pin	Mill-Max 8979-0-00-15-00-00-03-0
MP838	Press Fit Pin	Mill-Max 8979-0-00-15-00-00-03-0
MP839	Press Fit Pin	Mill-Max 8979-0-00-15-00-00-03-0
MP840	Press Fit Pin	Mill-Max 8979-0-00-15-00-00-03-0
MP841	Isolation Foil	Bergquist Sil-Pad K10
MP842	Isolation Foil	Bergquist Sil-Pad K10
MP851	Spring Clip for TO-247	Fischerelektronik THFU 2
MP852	Spring Clip for TO-247	Fischerelektronik THFU 2
MP853	Spring Clip for TO-247	Fischerelektronik THFU 2
MP854	Spring Clip for TO-220	Fischerelektronik THFU 3
<b>Others</b>		
B200	NTC Resistor	US Sensor TO103J2F
E200	Power Resistor	Vishay LTO100F4R700FTE3
G100	Voltage Regulator	Infineon Technologies TLE4264-2G
G111	Isolated DC/DC	MuRata MGJ2D122005SC
G112	Voltage Regulator	Infineon Technologies IFX25401TEV
G121	Isolated DC/DC	MuRata MGJ2D122005SC
G122	Voltage Regulator	Infineon Technologies IFX25401TEV
Id2	Oscilloscope Probe Adapter	LeCroy PK106-4
R110	Potentiometer	Vishay T93YA502KT20
R120	Potentiometer	Vishay T93YA502KT20

## References

### References

- [1] Infineon Technologies AG: AN2017-01, TO247PLUS – Description of the packages and assembly guidelines, Revision 2.0, 2017-02-10
- [2] Infineon Technologies AG: TRENCHSTOP™ 5 IGBT in a Kelvin Emitter Configuration – Performance Comparison and Design Guidelines, Revision 1.0, 2014-10-16
- [3] Markus Billmann: Coaxial Shunts – Technical Data, <http://www.ib-billmann.de/>, May 2014
- [4] PMK: Products – 5mm-L Probe Accessories, [http://www.pmk.de/en/products/5\\_0 mm l zubehoer](http://www.pmk.de/en/products/5_0_mm_l_zubehoer), September 2017
- [5] Teledyne LeCroy: Probes – Probe Parts and Kits – Probe Tip to PCB Adapter – PK106-4, <http://teledynelecroy.com/probes/probemodel.aspx?modelid=96&categoryid=3&mseries=434>, September 2017





## Revision History

### Major changes since the last revision

Page or Reference	Description of change
--	Revision 1.0 – First Release – Klaus Sobe

**Trademarks**

All referenced product or service names and trademarks are the property of their respective owners.

**Edition 2017-11-15**

**Published by**

**Infineon Technologies AG**

**81726 Munich, Germany**

**© 2017 Infineon Technologies AG.**

**All Rights Reserved.**

**Do you have a question about this document?**

**Email: [erratum@infineon.com](mailto:erratum@infineon.com)**

**Document reference  
AN2017-44**

**IMPORTANT NOTICE**

The information contained in this application note is given as a hint for the implementation of the product only and shall in no event be regarded as a description or warranty of a certain functionality, condition or quality of the product. Before implementation of the product, the recipient of this application note must verify any function and other technical information given herein in the real application. Infineon Technologies hereby disclaims any and all warranties and liabilities of any kind (including without limitation warranties of non-infringement of intellectual property rights of any third party) with respect to any and all information given in this application note.

The data contained in this document is exclusively intended for technically trained staff. It is the responsibility of customer's technical departments to evaluate the suitability of the product for the intended application and the completeness of the product information given in this document with respect to such application.

For further information on the product, technology, delivery terms and conditions and prices please contact your nearest Infineon Technologies office ([www.infineon.com](http://www.infineon.com)).

Please note that this product is not qualified according to the AEC Q100 or AEC Q101 documents of the Automotive Electronics Council.

**WARNINGS**

Due to technical requirements products may contain dangerous substances. For information on the types in question please contact your nearest Infineon Technologies office.

Except as otherwise explicitly approved by Infineon Technologies in a written document signed by authorized representatives of Infineon Technologies, Infineon Technologies' products may not be used in any applications where a failure of the product or any consequences of the use thereof can reasonably be expected to result in personal injury.