

Dobot Magician

Interface Description (V2)

Issue: V2

Date: 2019-07-01

Copyright © ShenZhen Yuejiang Technology Co., Ltd 2018. All rights reserved.

No part of this document may be reproduced or transmitted in any form or by any means without prior written consent of Yuejiang Technology Co., Ltd

Disclaimer

To the maximum extent permitted by applicable law, the products described (including its hardware, software and firmware, etc.) in this document are provided **AS IS**, which may have flaws, errors or faults. Yuejiang makes no warranties of any kind, express or implied, including but not limited to, merchantability, satisfaction of quality, fitness for a particular purpose and non-infringement of third party rights. In no event will Yuejiang be liable for any special, incidental, consequential or indirect damages resulting from the use of our products and documents.

Before using our product, please thoroughly read and understand the contents of this document and related technical documents that are published online, to ensure that the robotic arm is used on the premise of fully understanding the robotic arm and related knowledge. Please use this document with technical guidance from professionals. Even if follow this document or any other related instructions, Damages or losses will be happen in the using process, Dobot shall not be considered as a guarantee regarding to all security information contained in this document.

The user has the responsibility to make sure following the relevant practical laws and regulations of the country, in order that there is no significant danger in the use of the robotic arm.

Shenzhen Yuejiang Technology Co., Ltd

Address: 3F, Building NO.3, Tongfuyu Industrial Town, Nanshan District, Shenzhen, China

Website: www.dobot.cc

Preface

Purpose

This Document describes the interfaces, LED indicator description, and I/O interface description of Dobot Magician.

Intended Audience

This document is intended for:





- Customer Engineer
- Sales Engineer
- Installation and Commissioning Engineer
- Technical Support Engineer

Change History

Date	Change Description
2019/07/01	The first release

Symbol Conventions

The symbols that may be founded in this document are defined as follows.

Symbol	Description
 DANGER	Indicates a hazard with a high level of risk which, if not avoided, could result in death or serious injury
 WARNING	Indicates a hazard with a medium level or low level of risk which, if not avoided, could result in minor or moderate injury, robotic arm damage
 NOTICE	Indicates a potentially hazardous situation which, if not avoided, can result in robotic arm damage, data loss, or unanticipated result
 NOTE	Provides additional information to emphasize or supplement important points in the main text

Contents

1. Interface Description	1
1.1 Interface Board	1
1.2 LED Indicator	3
1.3 Multiplexed I/O Interface Description	3
1.3.1 Multiplexed Base I/O Interface Description	3
1.3.2 Multiplexed Forearm I/O Interface Description	6
1.3.3 Internal I/O Circuit	8
1.4 Example of External Device Connection	10

1. Interface Description

1.1 Interface Board

The interfaces of Dobot Magician are located on the back of the base and the Forearm respectively. Figure 1.1 shows the interfaces on the back of the base, and Table 1.1 lists the description.

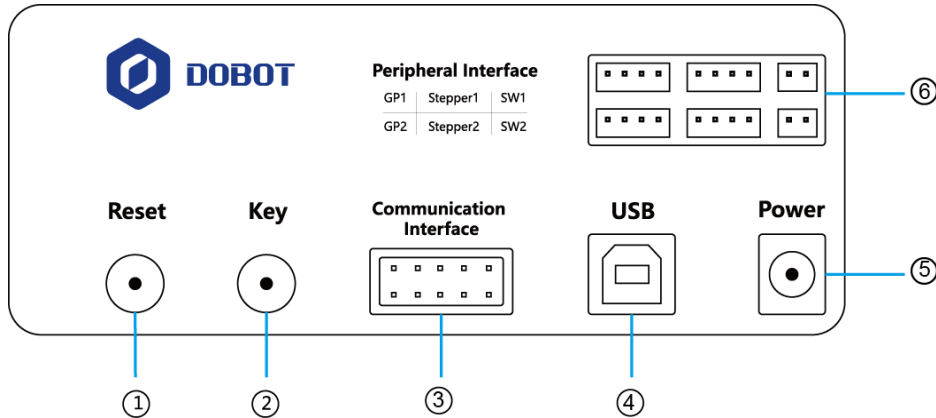

Figure 1.1 Interfaces in the base

Table 1.1 Interface Description

No.	Description
1	Reset key: Reset MCU program During resetting, the LED indicator on the base turns yellow. About 5 seconds later, if the LED indicator turns green, it indicates that the reset is successful
2	Functional key: <ul style="list-style-type: none"> Short press: Start running offline program Long press for 2 seconds: Starting homing procedure
3	I/O interface/UART interface: Connect with Bluetooth, WIFI and so on The Dobot protocol is adopted.
4	USB interface: Connect with PC
5	Power interface: Connect with power adaptor
6	Peripheral interface: Connect with air pump, extruder, sensor and other peripheral equipment. For details about peripheral interfaces, please see Table 1.2

Table 1.2 lists the peripheral interface description.

Table 1.2 Peripheral interface description

Interface	Description
SW1	Power interface of air pump; output 12V of controllable power
SW2	Output 12V of controllable power
Stepper1	User-defined stepper interface; extruder interface (3D printing mode)
Stepper2	User-defined stepper interface
GP1	Signal interface of air pump; color sensor interface; infrared sensor interface; user-defined general interface
GP2	User-defined general interface

Figure 1.2 shows the peripheral interface on the Forearm, and Table 1.3 lists the description of the peripheral interfaces.

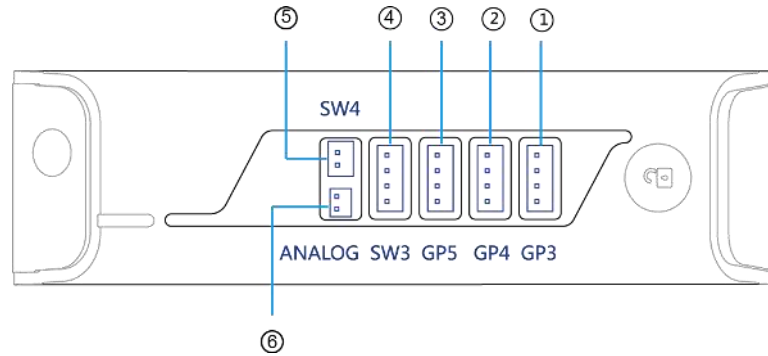

Figure 1.2 Peripheral interface in the Forearm

Table 1.3 Peripheral interface description

No.	Description
1	GP3, End-effector interface; R-axis servo interface; user-defined general interface
2	GP4, Auto levelling interface, user-defined general interface
3	GP5, Signal interface of laser engraving; user-defined general interface
4	SW3, Hot end interface (3D printing mode); Output 12V of controllable power
5	SW4, Fan interface (3D printing mode); Power interface of laser engraving; Output 12V of controllable power
6	ANALOG, Thermistor interface (3D printing mode)

1.2 LED Indicator

The LED indicator is located on the base, Table 1.4 lists the status description.

Table 1.4 LED indicator description

Status	Description
Green On	Dobot Magician works normally
Yellow On	Dobot Magician is in the starting status
Blue On	Dobot Magician is in the offline mode
Blue Blinking	Dobot Magician is running homing procedure or auto levelling
Red On	<ul style="list-style-type: none"> Dobot Magician is at the limited position Alarm is not cleared Connection of 3D printing kit is abnormal

1.3 Multiplexed I/O Interface Description

The addresses of the I/O interfaces in Dobot Magician are unified. Most of I/O interfaces have multiple functions, to control the peripheral equipment.

1.3.1 Multiplexed Base I/O Interface Description

1.3.1.1 Multiplexed UART Interface Description

Figure 1.3 shows the UART interface on the base, Table 1.5 lists the multiplexed I/O description.

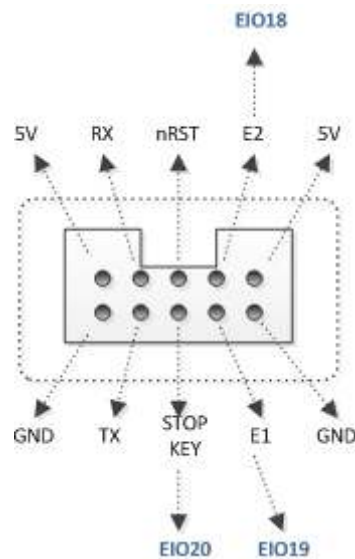

Figure 1.3 UART interface

Table 1.5 Multiplex I/O Description

Pin	Description	Level output	PWM	Level input	ADC	Whether pull up or pull down
5V	-	5V/1A output	-	-	-	-
GND	Ground	-	-	-	-	-
E2 (EIO18)	-	3.3V_20mA output	-	-	-	No pulling
E1 (EIO19)	-	-	-	3.3V/5V_20mA input	-	Pull up 1M to 3.3V
nRST	Hardware reset	-	-	3.3V_20mA input	-	Pull up 1M to 3.3V
STOP KEY (EIO20)	-	-	-	3.3V/5V_20mA input	-	Pull up 10K to 3.3V
RX	UART receive	-	-	3.3V/5V_20mA input	-	Pull up 1M to 3.3V
TX	UART send	3.3V/5V_20mA output	-	-	-	No pulling
5V	-	5V/1A output	-	-	-	-
GND	Ground	-	-	-	-	-

1.3.1.2 Multiplexed Peripheral Interface Description

Figure 1.4 shows the peripheral interface on the base, and Table 1.6 lists the multiplexed I/O description.

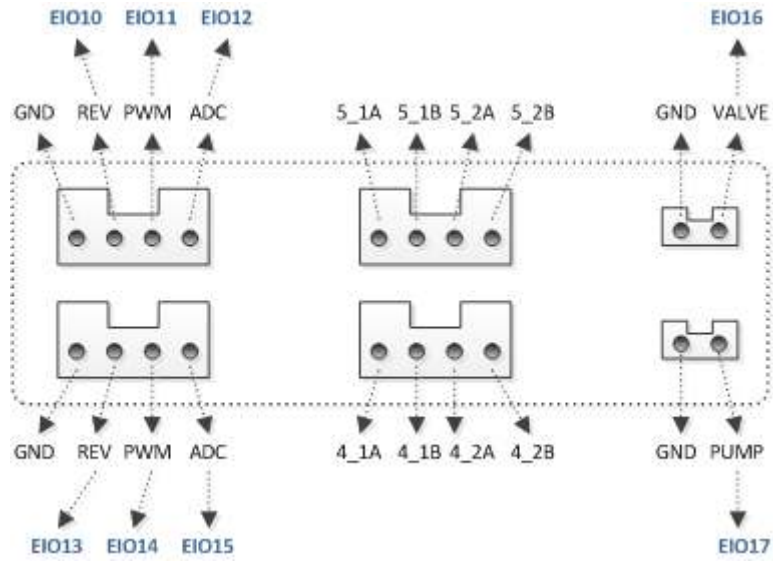

Figure 1.4 Peripheral Interface

Table 1.6 Multiplexed I/O Description

Interface	Pin	Description	Level output	PWM	Level input	ADC	Whether pull up or pull down	
SW1	VALVE (EIO16)	-	12V/1A output	-	-	-	-	
	GND	Ground	-	-	-	-	-	
SW2	PUMP (EIO17)	-	12V/1A output	-	-	-	-	
	GND	Ground	-	-	-	-	-	
Stepper1	5_1A	Default phase voltage and current	12V/0.9A output	-	-	-	-	
	5_1B			-	-	-	-	
	5_2A			-	-	-	-	
	5_2B			-	-	-	-	
Stepper2	4_1A			-	-	-	-	-
	4_1B			-	-	-	-	-
	4_2A			-	-	-	-	-
	4_2B			-	-	-	-	-
GP1	ADC(EIO12)	-	-	3.3V/5V_	-	Pull up		

Interface	Pin	Description	Level output	PWM	Level input	ADC	Whether pull up or pull down
					20mA input		1M to 3.3V
	PWM(EIO11)	-	3.3V_20mA output	√	-	-	No pulling
	REV(EIO110)	-	5V/1A output	-	-	-	-
	GND	Ground	-	-	-	-	-
GP2	ADC(EIO15)	-	3.3V_20mA output	-	3.3V/5V_20mA input	√ Notice: The maximum input voltage is 5V in ADC mode.	Pull down 1M to GND
	PWM(EIO14)	-	3.3V_20mA output	√	3.3V/5V_10mA input	-	Pull up 1M to 3.3V
	REV(EIO13)	-	5V/1A output	-	-	-	-
	GND	Ground	-	-	-	-	-

1.3.2 Multiplexed Forearm I/O Interface Description

Figure 1.5 shows the peripheral interface on the Forearm, [错误!未找到引用源。](#) lists the multiplexed I/O description.

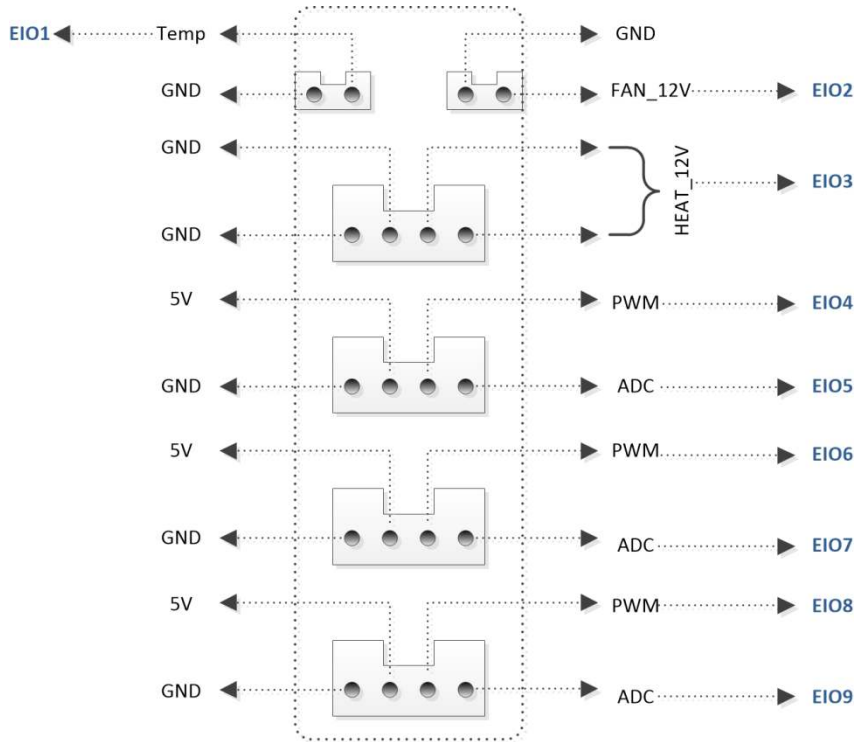

Figure 1.5 Peripheral interface in the Forearm

Table 1.7 Multiplexed I/O Description

Interface	Pin	Description	Level output	PWM	Level input	ADC	Whether pull up or pull down
ANALOG	Temp (EIO1)	-	-	-	-	-	Pull up 4.7K to 3.3V
	GND	Ground	-	-	-	-	-
SW4	FAN_12V (EIO2)	Fan power	12V/1A output	-	-	-	-
	GND	Ground	-	-	-	-	-
SW3	HEAT_12V (EIO3)	Heating-wire power	12V/3A output	-	-	-	-
	GND	Ground	-	-	-	-	-
	GND	Ground	-	-	-	-	-
GP5	ADC (EIO5)	-	-	-	3.3V/5V_20mA input	-	Pull up 1M to 3.3V
	PWM (EIO4)	-	3.3V_20	√	-	-	-

Interface	Pin	Description	Level output	PWM	Level input	ADC	Whether pull up or pull down
			mA output				No pulling
	5V	-	5V/1A output	-	-	-	-
	GND	Ground	-	-	-		-
GP4	ADC (EIO7)	-	-	-	3.3V/5V_20mA input		Pull up 1M to 3.3V
	PWM (EIO6)	-	3.3V_20mA output	√	-	-	No pulling
	5V	-	5V/1A output	-	-	-	-
	GND	Ground	-	-	-	-	-
GP3	ADC (EIO9)	-	-	-	3.3V/5V_20mA input	√ Notice: The maximum input voltage is 5V in ADC mode.	Pull down 1M to GND
	PWM (EIO8)	-	3.3V_20mA output	√	-	-	No pulling
	5V	-	5V/1A output	-	-	-	-
	GND	Ground	-	-	-	-	-

1.3.3 Internal I/O Circuit

- Pull up 1M to 3.3V

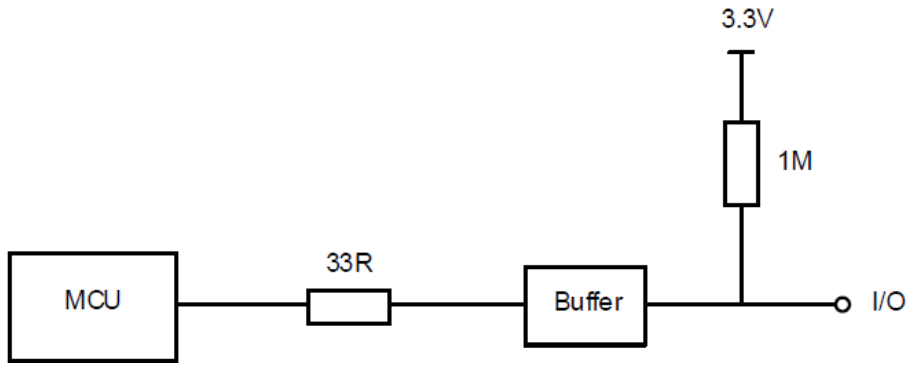

Figure 1.6 Pull up 1M to 3.3V

- 3.3V Pull up 10K to 3.3V

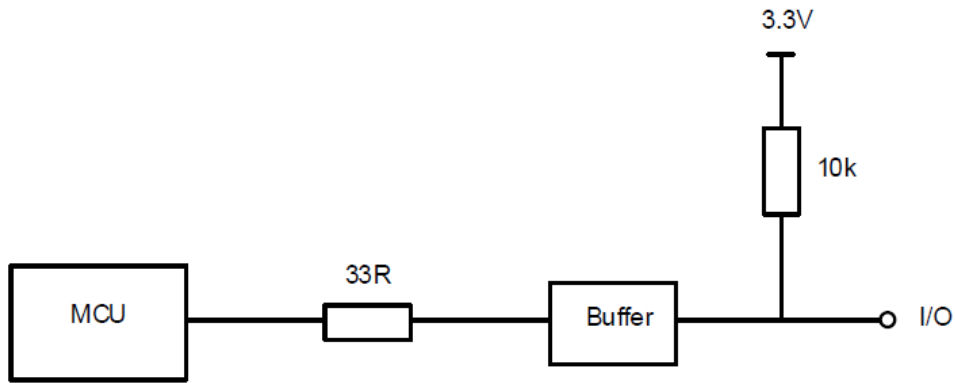

Figure 1.7 Pull up 10K to 3.3V

- Pull down 1M to ground

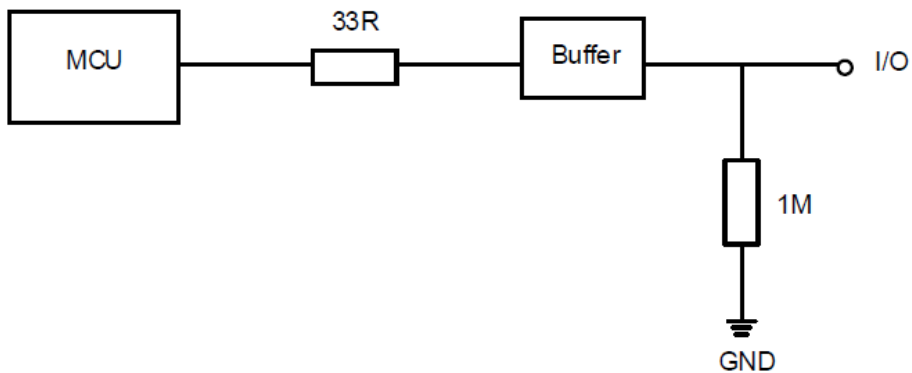

Figure 1.8 Pull down 1M to ground

- No pulling

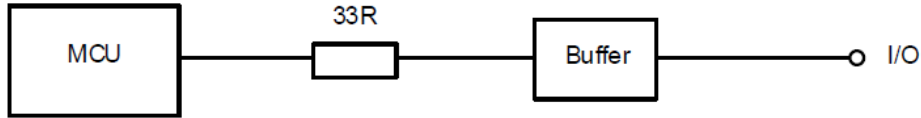

Figure 1.9 No pulling

1.4 Example of External Device Connection

We will take air-pump connection as an example in this chapter, the red box in Figure 1.10 错误!未找到引用源。 shows the external drive circuit.

- 12(I/O) is the output voltage of the I/O interface, OUTx is the output of the I/O interface (assuming that OUT1), GND is the ground of the I/O interface. Please select the proper outputs based on site requirements.
- 12V(External) is the external voltage, GND(External) is the ground corresponding to the external voltage.

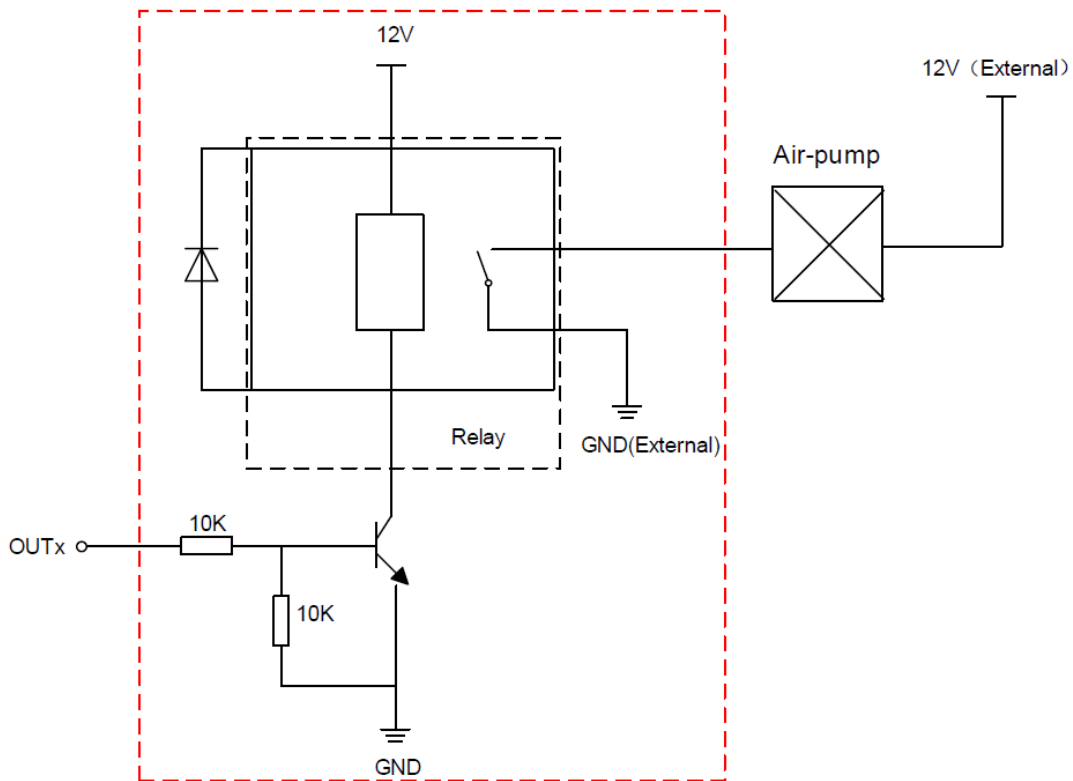

Figure 1.10 Example of external device connection