



## Product Specification for Approval

**WE ARE PLEASED IN SUBMITTING OUR SAMPLES WITH SPECIFICATION TO YOU FOR APPROVAL.**

<b>CUSTOMER</b>	:	
<b>DESCRIPTION</b>	:	<b>COMMON MODE CHOKE</b>
<b>MNC P/N</b>	:	<b>CM633SG332N</b>
<b>VERSION</b>	:	<b>A0</b>
<b>CUSTOMER P/N</b>	:	
<b>ISSUED DATE</b>	:	<b>2020/4/27</b>
<b>PHOTO OF PRODUCT</b>	:	
<b>WEIGHT</b>	:	<b>0.70g</b>
<b>MADE IN</b>	:	<b>CHINA</b>

APPROVED BY MNC		
PREPARED BY	CHECKED BY	APPROVED BY

APPROVED BY CUSTOMER
SIGNATURE OR STAMP

1. PLEASE SEND BACK US A COPY OF THE SPECIFICATION WITH YOUR STAMP OR SIGNATURE ONCE THE SAMPLES APPROVED.
2. IT WILL BE DEEMED THE SAMPLES TO BE APPROVED IF NO FEEDBACK.

东莞铭普光磁股份有限公司  
Add: Shipai Town, Dongguan City, Guangdong Province, China

TEL: +86-769-86921000  
FAX: +86-769-81701563



东莞铭普光磁股份有限公司

Dongguan Mentech Optical & Magnetic Co., Ltd.

HISTORY FOR REVISED SPECIFICATION

Part No. CM633SG332N

INDEX

- 1. INDEX----- 1
- 2. CHANGE RECORD----- 1
- 3. MECHANICAL----- 2
- 4. SCHEMATIC----- 3
- 5. PACKING----- 4
- 6. MATERIAL LIST----- 5
- 7. RECOMMENDED SOLDERING PROFILE----- 6

CHANGE RECORD

REV.	DESCRIPTION (Content or Reason For Change)	DATE	REVISOR
A0	Initial Release	2020/4/26	Alakay

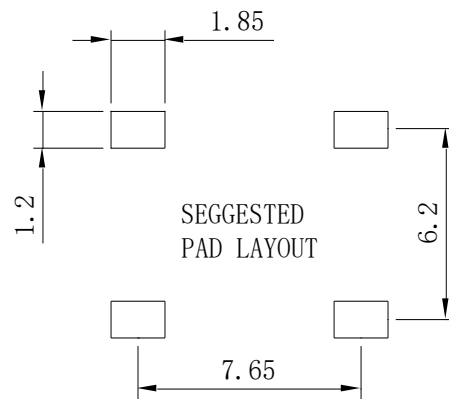
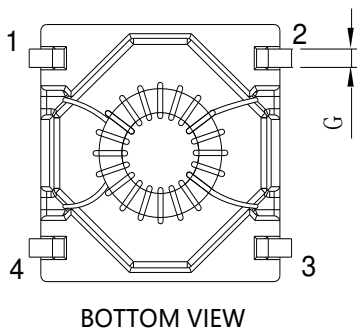
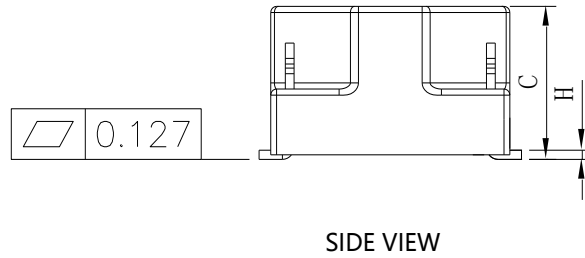
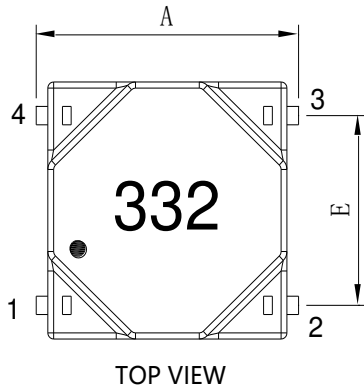
**SPECIFICATION**
**Part No. CM633SG332N**
**A. MECHANICAL:**

1.UNITS: mm

 2.Unless otherwise specified all tolerances are:  $\pm 0.25\text{mm}$ 

3.All pin length don't include tin icicles

DIM	MILLIMETERS			INCHES		
	MIN	NOM	MAX	MIN	NOM	MAX
<b>A</b>	8.50	9.00	9.50	0.335	0.354	0.374
<b>B</b>	7.90	8.40	8.90	0.311	0.331	0.350
<b>C</b>	/	/	5.60	/	/	0.220
<b>E</b>	6.05	6.20	6.35	0.238	0.244	0.250
<b>G</b>	0.45	0.60	0.75	0.018	0.024	0.030
<b>H</b>	0.15	0.30	0.45	0.006	0.012	0.018

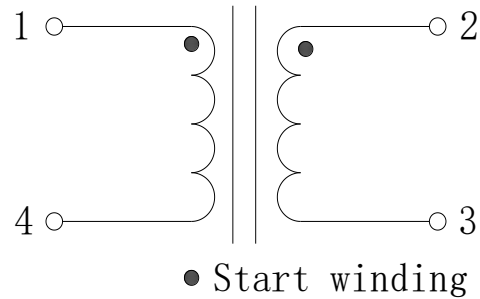
**SPECIFICATION**
**Part No. CM633SG332N**
**B. SCHEMATIC :**

**C. ELECTRICAL SPECIFICATION @25°C**

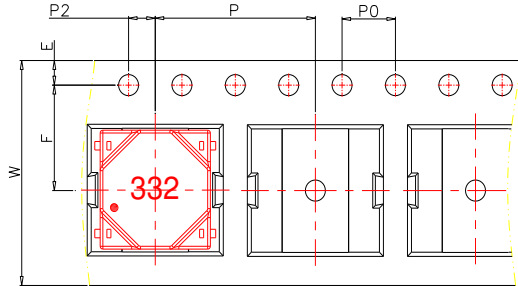
ITEM	SPECIFICATION	TEST CONDITION	TEST EQUIPMENT
INDUCTANCE: 1-4 = 2-3	3.3mH <sup>+50%</sup> / <sub>-30%</sub>	10KHz,0.1V	TH2819XB OR EQU.
DC RESISTANCE: 1-4 = 2-3	360mΩ Max		TH2512B OR EQU.
TURNS RATIO: 1-4 : 2-3	1:1 ±5%		TH2819XB OR EQU.
HI-POT: 1-4 to 2-3	500Vac	1mA,1S,50Hz	TOS7200 OR EQU.
RATED CURRENT	ΔT ≤ 40°C	0.52A Max	WK3260B+WK3265B
OPERATING TEMPERATURE RANGE	-40°C to 125°C (Including self temperature rise)		
STORAGE TEMPERATURE RANGE	-40°C to 125°C		

**D.PACKAGE**
**Part No. CM633SG332N**
**1. PACKING:**
**a. PACKAGING AS BELOW (ONLY FOR REFERENCE):**

ITEM	DIM.
W	16.0±0.3
F	7.5±0.1
E	1.75±0.1
P <sub>0</sub>	4.0±0.1
P <sub>2</sub>	2.0±0.1
P	12.0±0.1



User direction of feed →

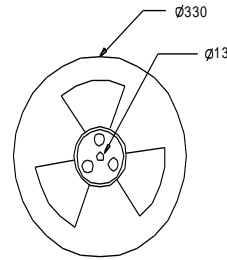
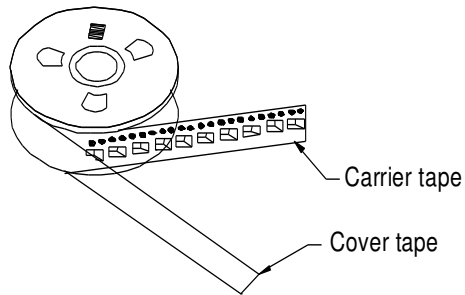

Put the reel into the carton

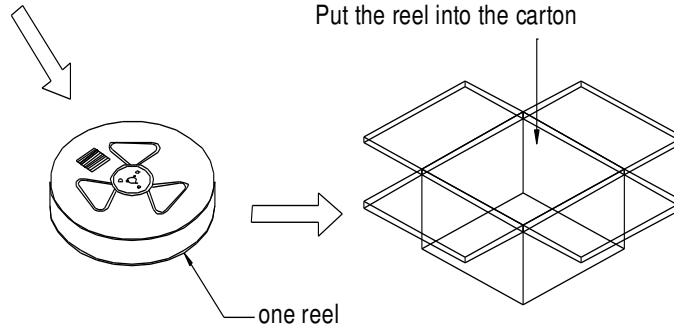

**b. Q'TY:**
900 pcs/reel
10 reel/carton
9000 pcs/carton
**c. LABEL:**

**REMARK:**

ABOVE PACKING IS FOR YOUR REFERENCE ONLY, WHICH MIGHT BE CHANGED WITHOUT NOTICE.

**MATERIAL LIST**
**Part No. CM633SG332N**
**E.BOM**

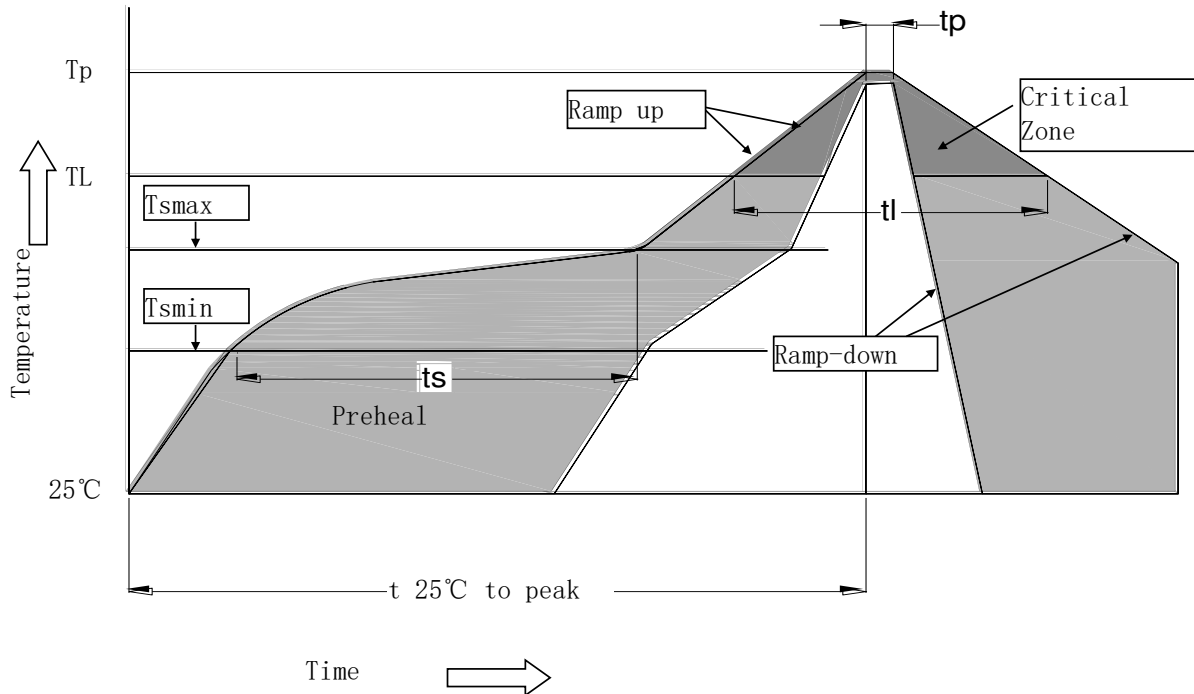
MATERIAL LIST					
NO.	ITEM	MATERIAL	RATING	SUPPLIER OF MATERIAL	UL
1	CASE	PM 9630	150°C	SUMITOMO BAKELITE CO LTD OR EQU.	E41429
2	CORE	Ferrite Mn-Zn	-----	YEAN SHING TECHNOLOGY (DONGGUAN) LIMITED	N/A
		Ferrite Mn-Zn	-----	ZHONGSHAN CITY TANZHOU TOWN CHUANGRICI ELECTRONIC FACTORY OR EQU.	N/A
3	COPPER WIRE	*xUEW180	180°C	ZHUHAI SUNTEK WIRE CO LTD OR QUU.	E234867
		UEWH/U@	180°C	PACIFIC ELECTRIC WIRE & CABLE CO., LTD. OR QUU.	E201757
4	VARNISH	V1630FS	150°C	ELANTAS ELECTRICAL INSULATION ELANTAS PDG INC OR EQU.	E213437
5	SOLDER	Sn99.3Cu0.7 LF-303	-----	ELECTROLOY METAL(SHENZHEN)CO.,LTD. OR EQU.	N/A

**RECOMMENDED SOLDERING PROFILE**
**Part No. CM633SG332N**
**1. RECOMMENDED REFLOW SOLDERING PROFILE:**

$$T_L = 217^\circ\text{C}$$

$$T_P = 265^\circ\text{C}$$

$$t_s = 60-180\text{s} \quad T_{s\text{ max}} = 200^\circ\text{C} \quad T_{s\text{ min}} = 150^\circ\text{C}$$

$$T_L = 60-150\text{s}$$

$$T_P = 20-40\text{s}$$

$$T_{25^\circ\text{C to peak}} = 8\text{ min max}$$

$$\text{Ramp up rate} = 3^\circ\text{C/s max}$$

$$\text{Ramp down rate} = 6^\circ\text{C/s max}$$

\*RoHS Compliant

\*Solder Paste SAC 305 Sn 96.5/Ag 3.0/Cu 0.5

\*Silkscreen thickness: 0.15mm Min

**2. MOISTURE SENSITIVE LEVEL:**

2.1. Level: 1

2.2. Shelf Life: Unlimited

2.3. Storage Condition:  $\cong 30^\circ\text{C}/85\% \text{ RH}$