

# ISL28617SMXXEV1Z User's Guide

## Introduction

The ISL28617SMXXEV1Z evaluation board is designed to assess the performance of the ISL28617 differential input, differential output, precision instrumentation amplifier (in-amp). With an input voltage range up to  $\pm 34V$ , a supply voltage range of  $8V (\pm 4V)$  to  $40V (\pm 20V)$  and gain ranging from 0.1 to 10,000, this in-amp is ideal for a wide variety of applications. The gain accuracy is limited only by the matching of the gain resistors, and the output is capable of driving rail-to-rail.

The board is configured for ease of use, but allows for more complex variations to fit the user's need, as discussed in the following sections. The evaluation board includes test points ( $V_{CC}$ ,  $V_{EE}$ , and GND) for the power supply inputs, and is configured for operation from split supplies between  $\pm 4V$  to  $\pm 20V$ . There are two pairs of test points for the differential input and output as well ( $V_{IN+}$ ,  $V_{IN-}$ ,  $V_{OUT+}$ , and  $V_{OUT-}$ ). The board is available in three different gain configurations: 0.25, 10 and 100. Ordering information is shown in Table 3.

## Reference Documents

- ISL28617 Data sheet, [FN6562](#)

## Power Supplies

External power connections are made to the positive supply rail (TP1), the negative supply rail (TP9), and ground (TP4) for split supply operation. The operating voltage range is  $\pm 4V$  to  $\pm 20V$ . The in-amp has two distinct sets of power supplies; one on the input stage and one on the output stage. For the evaluation board, the output stage supplies are tied to the input stage supplies, and the common mode voltage is tied to ground. The supply voltage on the input stage must be 3V above and below the maximum and minimum input signal voltage, respectively. Note that while the output stage is rail-to-rail, the feedback returns to the input stage, which is not rail-to-rail. Therefore, the input power supply must be 3V above and below the maximum and minimum output signal as well. Table 2 provides suggested supply voltages for the three standard boards. For more information, reference "Setting the Power Supply Voltages" on page 13 of the ISL28617 data sheet.

If the user wants to control the output supplies separately, the R3 and R5 resistors must be removed, and the  $V_{CO}$  (TP2) and  $V_{EO}$  (TP6) test points are used for the positive output supply and negative output supply respectively (reference evaluation board schematic in Figure 4). Single supply operation requires removing R7 and attaching the desired common mode voltage to the  $V_{REF}$  (TP10) test point. Using the separate supply feature enables input signals riding on a high common mode voltage to be level shifted to a low voltage device such as an analog to digital converter (ADC). The rail-to-rail output stage can be powered from the same supplies as the ADC while preserving the in-amp's maximum input dynamic range. Once again, the positive input power supply must be 3V above the maximum output signal, and the negative input power supply must be 3V below the minimum output signal.

## Amplifier Configuration

The ISL28617 evaluation board schematic is shown in Figure 4 with a closed loop gain of 10 and split supply operation with input and output supplies tied together. Other gain options are 0.25 and 100, with the required resistor and capacitor changes listed in Table 1. The in-amp gain is controlled through R1 and R2, the feedback and input resistors, with the following simple formula:

$$A_V = \frac{R_1}{R_2} \quad (\text{EQ. 1})$$

R1 and R2 also limit the maximum signal size at the input and output due to the amplifier architecture. Table 2 shows the signal limits for the boards at the preset resistor values. For more information, refer to "Setting the Feedback Gain  $R_{FB}$ " and "Setting the Input Gain  $R_{IN}$ " on page 13 of the ISL28617 data sheet.

The evaluation board allows the user to add an optional low pass RC filter to the signal path. R8, R9, and C6 create a filter on the output of the in-amp, while R10, R11, and C7 create a filter on the input. The gain of 0.25 board option includes a filter on the input to avoid gain peaking at the limits of the gain bandwidth product.

**TABLE 1. COMPONENTS PARTS LIST**

DEVICE #	VALUE	DESCRIPTION
C1-C5	0.01 $\mu$ F	Decoupling Capacitors
C6	Open	Optional Output Filter Capacitor
C7	Open	Optional Input Filter Capacitor
	1.2pF	Input Filter Capacitor ( <b>G = 0.25</b> )
D1, D2	S1A	Reverse Power Protection
R1	30.1k $\Omega$	Feedback Gain Resistor ( <b>G = 0.25</b> )
	100k $\Omega$	Feedback Gain Resistor ( <b>G = 10, 100</b> )
R2	121k $\Omega$	Input Gain Resistor ( <b>G = 0.25</b> )
	10k $\Omega$	Input Gain Resistor ( <b>G = 10</b> )
	1k $\Omega$	Input Gain Resistor ( <b>G = 100</b> )
R3, R5, R7	0 $\Omega$	User Selectable Resistors
R8, R9	0 $\Omega$	Optional Output Filter Resistors
R10, R11	0 $\Omega$	Optional Input Filter Resistors
	49.9k $\Omega$	Input Filter Resistors ( <b>G = 0.25</b> )
R4, R6	1M $\Omega$	Ground Input for Stability
U1	ISL28617	TSSOP 24-Pin Package

# Application Note 1748

TABLE 2. SUGGESTED INPUT VOLTAGE AND POWER SUPPLY LIMITS

GAIN	SUGGESTED $V_{IN}$ LIMIT	OVERLOAD $V_{IN}$ LIMIT	SUGGESTED SUPPLY VOLTAGE
0.25	$\pm 10V$	$\pm 12V$	$\pm 15V$
10	$\pm 0.8V$	$\pm 1V$	$\pm 13V$
100	$\pm 0.08V$	$\pm 0.1V$	$\pm 13V$

TABLE 3. ORDERING INFORMATION

BOARD PART NUMBER	GAIN	TYPE
ISL28617SMR25EV1Z	0.25	Evaluation Board
ISL28617SM10EV1Z	10	Evaluation Board
ISL28617SM100EV1Z	100	Evaluation Board

## ISL28617SMXXEV1Z Evaluation Board Layout

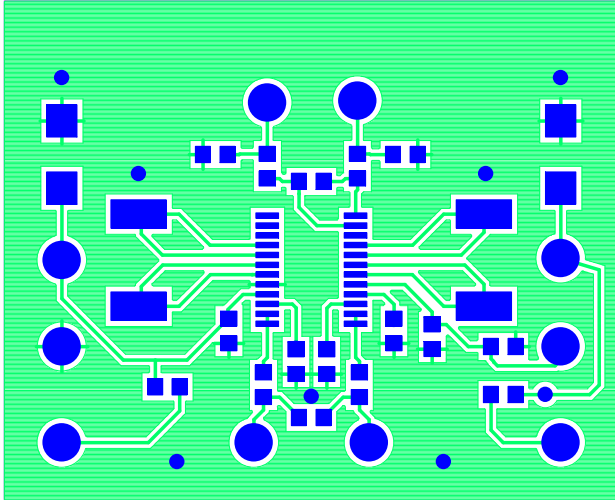

FIGURE 1. TOP LAYER

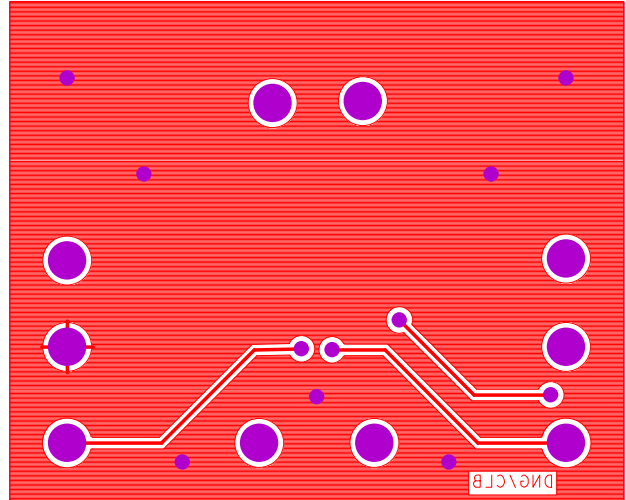

FIGURE 2. BOTTOM LAYER

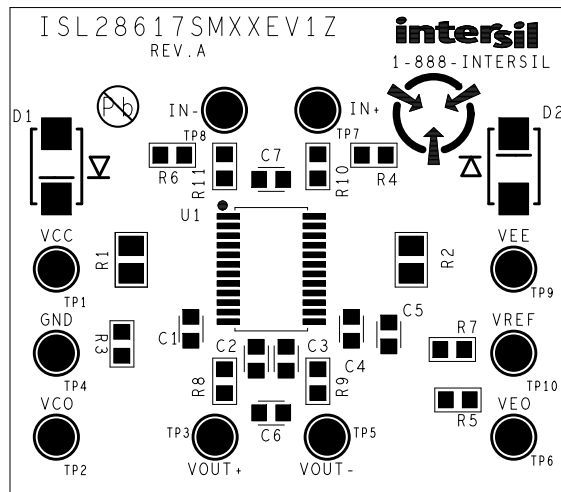

FIGURE 3. ASSEMBLY DRAWING

# ISL28617SMXXEV1Z Schematic

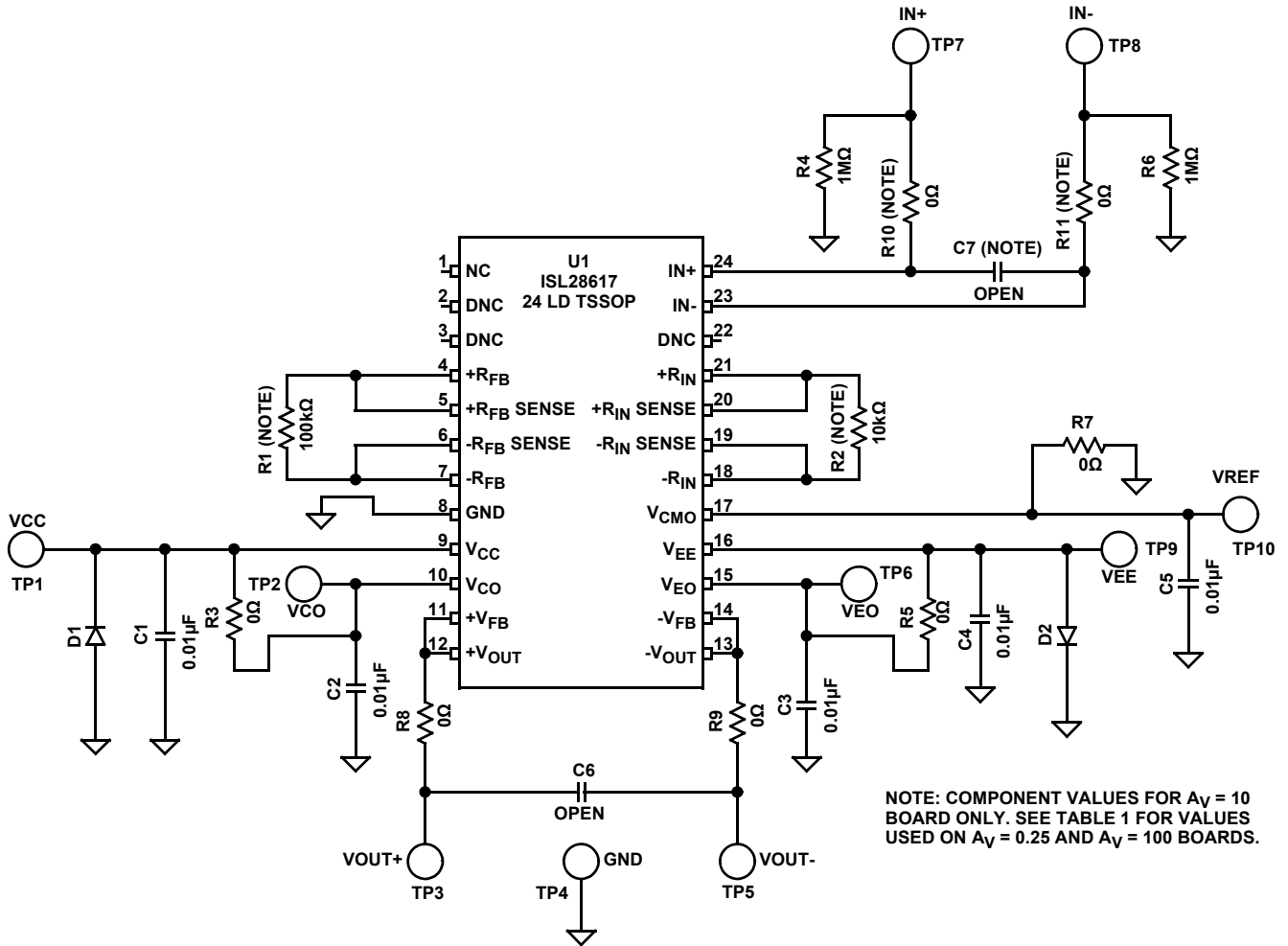

FIGURE 4. ISL28617SM10EV1Z ( $A_V = 10$ ) EVALUATION BOARD SCHEMATIC

## Application Note 1748

**TABLE 4. BILL OF MATERIALS FOR  $A_V = 10$  BOARD (ISL28617SM10EV1Z)**

PART #	REF DES	QTY	DESCRIPTION	MANUFACTURER
GRM39X7R103K050	C1-C5	5	CAP, SMD, 0603, 0.01 $\mu$ F, 50V, 10%, X7R, ROHS	Murata
DNP	C6, C7	0	DO NOT POPULATE	
5000	TP1, TP9	2	CONN-MINI TEST POINT, VERTICAL, RED, ROHS	Keystone
5001	TP4	1	CONN-MINI TEST POINT, VERTICAL, BLK, ROHS	Keystone
5002	TP7, TP8	2	CONN-MINI TEST POINT, VERTICAL, WHITE, ROHS	Keystone
5004	TP3, TP5	2	CONN-MINI TEST POINT, VERTICAL, YEL, ROHS	Keystone
S1A	D1, D2	2	DIODE-RECTIFIER, SMD, 2P, SMA, 50V, 1A, 1.4W, ROHS	Fairchild
ISL28617FVZ	U1	1	IC-40V R/R OUTPUT ADC DRIVER, 24P, TSSOP, 4X5, ROHS	Intersil
ERA-6YEB103V	R2	1	RES, SMD, 0805, 10k, 1/10W, 0.1%, MF, ROHS	Panasonic
ERA-6AEB104V	R1	1	RES, SMD, 0805, 100k, 1/8W, 0.1%, 25ppm, MF, ROHS	Panasonic
ERJ-3GEY0R00V	R3, R5, R7-R11	7	RES, SMD, 0603, 0 $\Omega$ , 1/10W, TF, ROHS	Panasonic
ERJ-3EKF1004V	R4, R6	2	RES, SMD, 0603, 1M, 1/10W, 1%, TF, ROHS	Panasonic
DNP	TP2, TP6, TP10	0	DO NOT POPULATE	

Intersil Corporation reserves the right to make changes in circuit design, software and/or specifications at any time without notice. Accordingly, the reader is cautioned to verify that the Application Note or Technical Brief is current before proceeding.

For information regarding Intersil Corporation and its products, see [www.intersil.com](http://www.intersil.com)