

REVISIONS			
REV	DESCRIPTION, ECN, EAR NO.	DATE	APP'D
A	PROPOSAL	JAN 16/19	L.CHAN

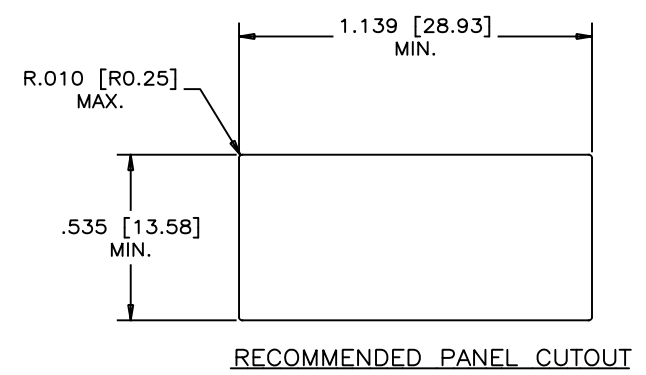

$\phi .035 \pm .002$ [$\phi 0.89 \pm 0.05$]
24 HOLES REQ'D
BASED ON 2 LEDS PER PORT

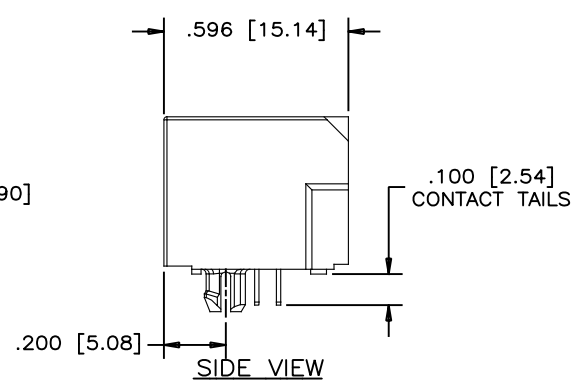
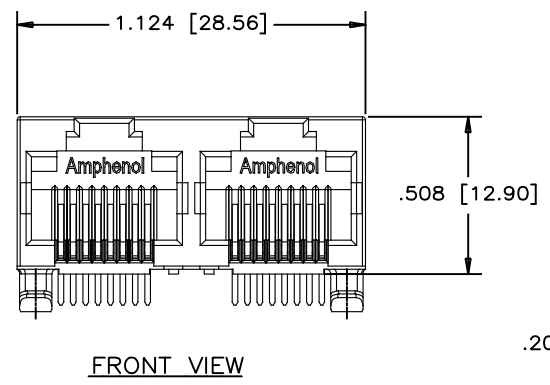
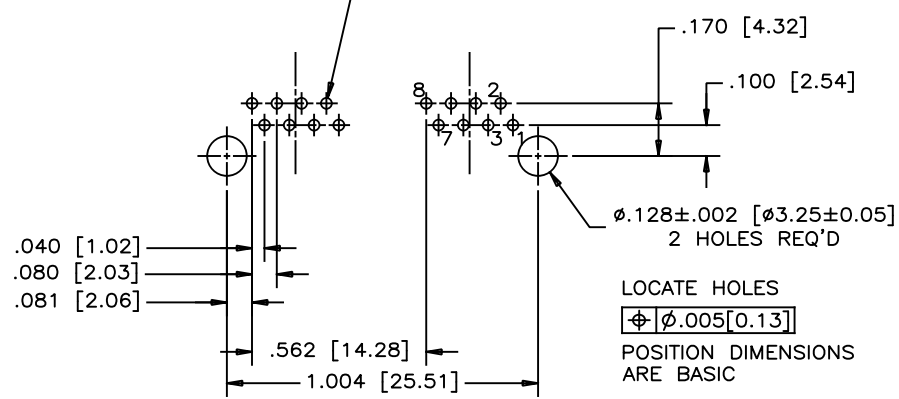

- MATERIALS:**
PLASTIC HOUSING: HIGH TEMPERATURE THERMOPLASTIC
FLAMMABILITY RATING UL 94V-0, COLOUR: BLACK

CONTACTS: PHOSPHOR BRONZE
PLATING: SELECTIVE GOLD PLATING ON MATING SURFACES,
SEE AMPHENOL PART NUMBER FOR DETAIL.
50 μ" [1.27 MICRONS] MIN. NICKEL UNDERPLATE
100 μ" [2.54 MICRONS] MIN. MATTE TIN ON CONTACT TAILS
- RECOMMENDED SOLDERING TEMPERATURE:**
WAVE SOLDERING AT 260° C MAXIMUM FOR 5 SEC MAXIMUM.

- PART NUMBER:** RJE39-288-0X00
GOLD PLATING OPTION
0=GOLD FLASH
1=6u" GOLD PLATING
2=15u" GOLD PLATING
3=30u" GOLD PLATING
4=50u" GOLD PLATING



UNLESS SPECIFIED OTHERWISE		DRAWN	W.QIU	DATE	JAN18/19	Amphenol Canada Corp. Commercial Products
PRIMARY UNITS	INCH	CHECKED	L.CHAN	DATE	JAN16/19	
SECONDARY UNITS	MILLIMETER	M.E. APP'D				TITLE
REFERENCE IN PARENTHESES		Q.A. APP'D				2 PORT HIGH SPEED MODULAR JACK, 8 POSITION, 8 CONTACTS, UNSHIELDED, WITHOUT LED- RoHS COMPLIANT
GENERAL TOLERANCES		DWG APPR.				DWG. NO.
1 DECIMAL PLACE	±0.025	ENG. REL. NO.				P-RJE39-288-0X00
2 DECIMAL PLACES	±0.020	REF.				REV
3 DECIMAL PLACES	±0.015	THIRD ANGLE PROJECTION				A
ANGULAR DEGREES	±1.0°	DO NOT SCALE DRAWING				CODE ID NO. 03554 DWG SIZE: c SCALE: N/A SHEET 1 OF 1

THIS DOCUMENT CONTAINS PROPRIETARY INFORMATION AND SUCH INFORMATION MAY NOT BE DISCLOSED TO OTHERS FOR ANY PURPOSE OR USED FOR MANUFACTURING PURPOSES WITHOUT WRITTEN PERMISSION FROM AMPHENOL CANADA CORP.