

THROUGH HOLE

SHEET #	MODULE HEIGHT	LATCH	ROTATION	PCB PATTERN
2	.125	PLASTIC	STANDARD(LEFT)	PATTERN 1
3	.125	PLASTIC	REVERSE(RIGHT)	PATTERN 3
4	.160	PLASTIC	STANDARD(LEFT)	PATTERN 1
5	.160	PLASTIC	STANDARD(LEFT)	PATTERN 2
6	.160	PLASTIC	REVERSE(RIGHT)	PATTERN 3
7	.160	METAL	STANDARD(LEFT)	PATTERN 1
8	.160	METAL	STANDARD(LEFT)	PATTERN 2
9	.160	METAL	REVERSE(RIGHT)	PATTERN 3
10	.190	PLASTIC	STANDARD(LEFT)	PATTERN 1
11	.190	PLASTIC	STANDARD(LEFT)	PATTERN 2
12	.190	PLASTIC	REVERSE(RIGHT)	PATTERN 3
13	.190	METAL	STANDARD(LEFT)	PATTERN 1
14	.190	METAL	STANDARD(LEFT)	PATTERN 2
15	.190	METAL	REVERSE(RIGHT)	PATTERN 3
16	.250	PLASTIC	STANDARD(LEFT)	PATTERN 1
17	.250	PLASTIC	STANDARD(LEFT)	PATTERN 2
18	.250	PLASTIC	REVERSE(RIGHT)	PATTERN 3
19	.250	METAL	STANDARD(LEFT)	PATTERN 1
20	.250	METAL	STANDARD(LEFT)	PATTERN 2
21	.250	METAL	REVERSE(RIGHT)	PATTERN 3
22	.290	PLASTIC	STANDARD(LEFT)	PATTERN 1
23	.290	PLASTIC	STANDARD(LEFT)	PATTERN 2
24	.290	PLASTIC	REVERSE(RIGHT)	PATTERN 3
25	.290	METAL	STANDARD(LEFT)	PATTERN 1
26	.290	METAL	STANDARD(LEFT)	PATTERN 2
27	.290	METAL	REVERSE(RIGHT)	PATTERN 3

THROUGH HOLE PATTERNS

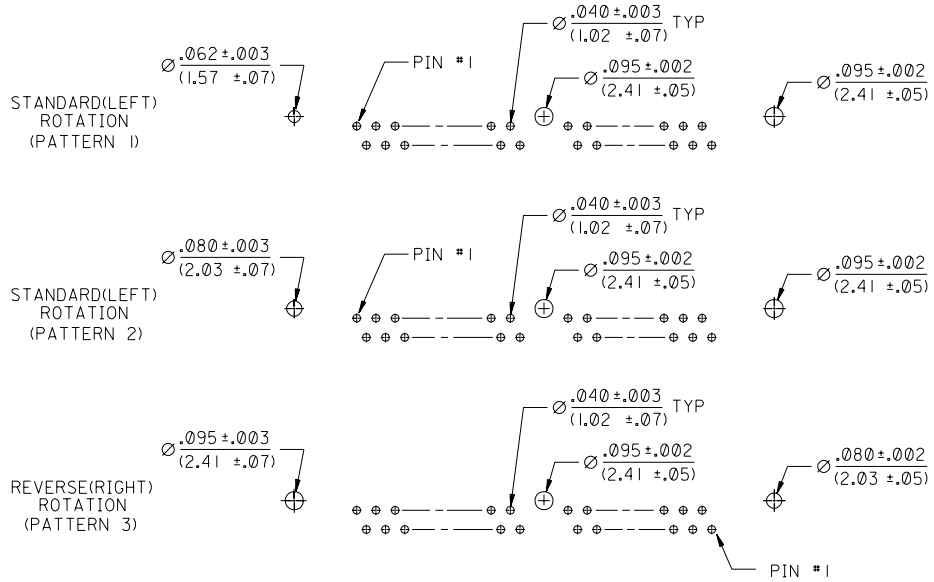

SURFACE MOUNT

SHEET #	MODULE HEIGHT	LATCH	ROTATION	PCB PATTERN
28	.160	METAL	STANDARD(LEFT)	PATTERN 4
29	.160	METAL	REVERSE(RIGHT)	PATTERN 5
30	.190	METAL	STANDARD(LEFT)	PATTERN 4
31	.190	METAL	REVERSE(RIGHT)	PATTERN 5
32	.250	METAL	STANDARD(LEFT)	PATTERN 4
33	.250	METAL	REVERSE(RIGHT)	PATTERN 5
34	.290	METAL	STANDARD(LEFT)	PATTERN 4
35	.290	METAL	REVERSE(RIGHT)	PATTERN 5

SURFACE MOUNT PATTERNS

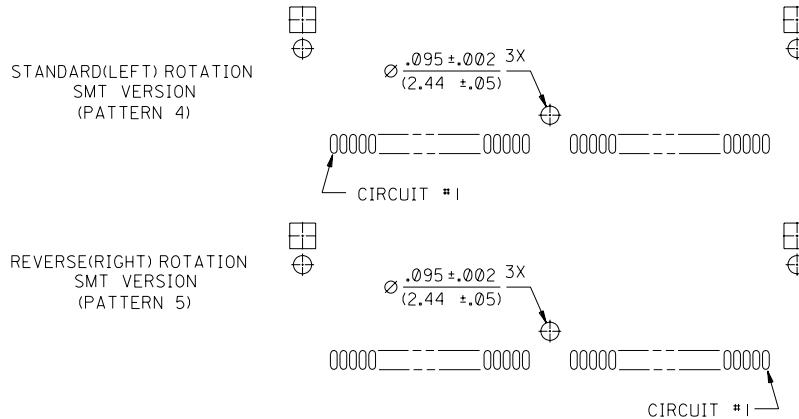

P.C. BOARD HOLE PATTERNS

35	D
34	D
33	D
32	D
31	D
30	D
29	D
28	D
27	D
26	D
25	D
24	D
23	D
22	D
21	D
20	D
19	D
18	D
17	D
16	D
15	D
14	D
13	D
12	D
11	D
10	D
9	D
8	D
7	D
6	D
5	D
4	D
3	D
2	D
1	D

DIMENSIONS SHOWN (METRIC) INCH  
 UNLESS OTHERWISE SPECIFIED  
 TOLERANCES: ANGULAR ± 1/2°  
 INCH METRIC  
 3 PLACE ± .01 ---  
 2 PLACE ± .014 ± 0.25  
 1 PLACE --- ± 0.36  
 DRAFT WHERE APPLICABLE MUST  
 REMAIN WITHIN DIMENSIONS  
 DRWG. BY AMD CHK'D. BY  
 APP'D. BY SCALE 2 : 1  
 DIMENSIONS SHOWN (METRIC) INCH  
 UNLESS OTHERWISE SPECIFIED  
 TOLERANCES: ANGULAR ± 1/2°  
 INCH METRIC  
 3 PLACE ± .01 ---  
 2 PLACE ± .014 ± 0.25  
 1 PLACE --- ± 0.36  
 DRAFT WHERE APPLICABLE MUST  
 REMAIN WITHIN DIMENSIONS  
 DRWG. BY AMD CHK'D. BY  
 APP'D. BY SCALE 2 : 1  
 FILE NAME SD78968001.DGN  
 THIS DRAWING CONTAINS INFORMATION THAT IS PROPRIETARY TO MOLEX INC. AND SHOULD NOT BE USED WITHOUT WRITTEN PERMISSION.  
 TITLE SALES ASSEMBLY  
 .05 PITCH RIGHT ANGLE  
 SIMM SOCKET FAMILY  
 MOLEX INCORPORATED  
 LITSE, ILL. 60532 U.S.A.  
 SHEET NO. 1 OF 35  
 DATE 11/11/93  
 PART NO. SDA-78968-\*\*\*\*  
 SEE CHART  
 MFG, SH, REV, LTR, REVISIONS  
 REVISIONS ONLY ON CAD SYSTEM

78968

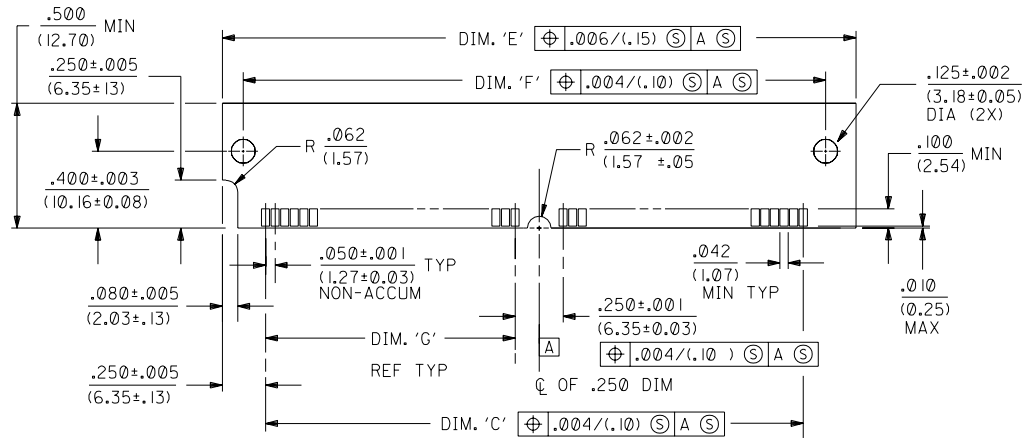

"SIMM" P.C. BOARD LAYOUT

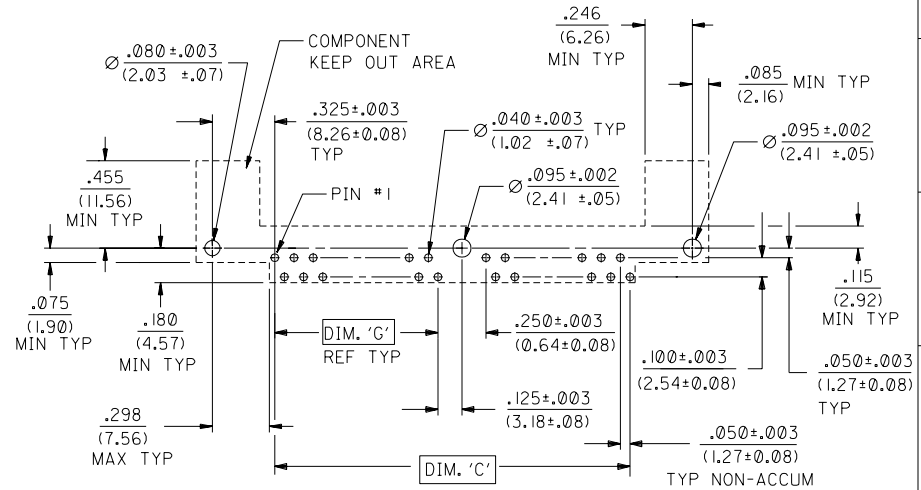
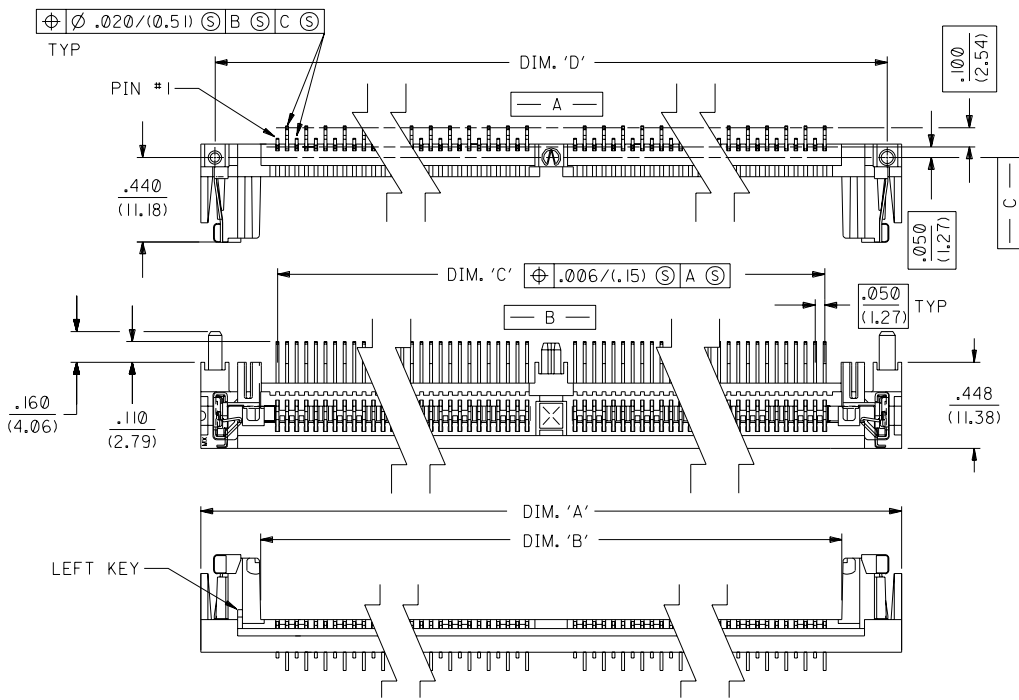

RECOMMENDED SOCKET P.C. BOARD HOLE PATTERN

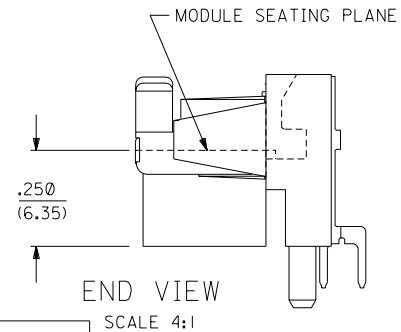

END VIEW SCALE 4:1

- NOTES:
- CARD SLOT ACCEPTS .050 +.004/- .003 P.C. BOARDS (MEASURED OVER P.C. PADS).
  - CENTER PEG IS AN INTERFERENCE FIT TO RECOMMENDED P.C. BOARD HOLE. (WHERE APPLICABLE)
  - PRODUCT SPEC PS-78968 APPLIES
- MATERIALS:
- HOUSING- LCP , GLASS FILLED, 94V-0, COLOR: BLACK.
  - TERMINAL- PHOSPHOR BRONZE
- PLATING - SEE CHART
- THE PRIMARY SHIPPING CARTON WILL BE LABELED "COMPLIANT TO ROHS DIRECTIVE 2002/95/EC AND ELV ANNEX II OF DIRECTIVE 2000/53/EC". CARTONS WITHOUT THIS LABEL MAY CONTAIN PRODUCT WITH LEAD.

CIRCUITS	DIM. 'A'	DIM. 'B'	DIM. 'C'	DIM. 'D'	DIM. 'E'	DIM. 'F'	DIM. 'G'	ENG. NUMBER TIN PLATING	EDP NUMBER TIN PLATING	ENG. NUMBER GOLD PLATING	EDP NUMBER GOLD PLATING
40	2.950/(74.93)	2.327/(59.11)	2.150/(54.61)	2.800/(71.12)	2.650/(67.31)	2.384/(60.55)	.950/(24.13)	-4046	15-82-1542	-4047	15-82-1549
64	4.150/(105.41)	3.527/(89.58)	3.350/(85.09)	4.000/(101.60)	3.850/(97.79)	3.584/(91.03)	1.550/(39.37)	-6445	15-82-1543	-6446	15-82-1550
68	4.350/(110.49)	3.727/(94.66)	3.550/(90.17)	4.200/(106.68)	4.050/(102.87)	3.784/(96.12)	1.650/(41.91)	-6845	15-82-1544	-6846	15-82-1551
72	4.550/(115.57)	3.927/(99.74)	3.750/(95.25)	4.400/(111.76)	4.250/(107.95)	3.984/(101.19)	1.750/(44.45)	-7248	15-82-1538	-7230	15-82-0312
80	4.950/(125.73)	4.327/(109.90)	4.150/(105.41)	4.800/(121.92)	4.650/(118.11)	4.384/(111.35)	1.950/(49.53)	-8046	15-82-1546	-8047	15-82-1552
84	5.150/(130.81)	4.527/(114.98)	4.350/(109.22)	5.000/(127.00)	4.850/(123.19)	4.584/(116.43)	2.050/(52.07)	-8446	15-82-1547	-8447	15-82-1553
100	5.950/(151.13)	5.327/(135.13)	5.150/(130.81)	5.800/(147.32)	5.650/(143.51)	5.384/(136.75)	2.450/(62.23)	-1045	15-82-1548	-1030	15-82-0311

DIMENSIONS SHOWN (METRIC) INCH  
UNLESS OTHERWISE SPECIFIED  
TOLERANCES: ANGULAR 1/2°

3 PLACE	± .01	---
2 PLACE	± .014	± 0.25
1 PLACE	---	± 0.36

DRAFT WHERE APPLICABLE MUST REMAIN WITHIN DIMENSIONS

DRG. BY: AMD  
CHK'D. BY: SCALE: 2:1

FILE NAME: SDA7896820  
APP. BY: GCA

THIS DRAWING CONTAINS INFORMATION THAT IS PROPRIETARY TO MOLEX INC. AND SHOULD NOT BE USED WITHOUT WRITTEN PERMISSION.

SALES ASSM, METAL LATCH  
.250 MOD. HGT. ,LEFT(STD.) KEY,  
RIGHT ANGLE SIMM SOCKET

MOLEX INCORPORATED  
LISLE, ILL. 60532 U.S.A.

SHEET NO. 20  
DATE 11/11/93

DRWG. NO. SDA-78968-\*\*\*\*

REVISIONS

D	SEE SHEET 1
A	SEE SHEET 1