

6

5

4

3

2

1

APPROVED: _____
DATE: _____ TITLE: _____

Rev	AWO #	Description	Date	Appr
-		RELEASED	11/23/18	

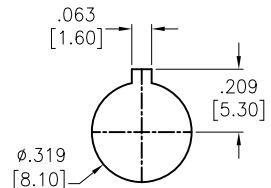

RECOMMENDED PANEL CUT

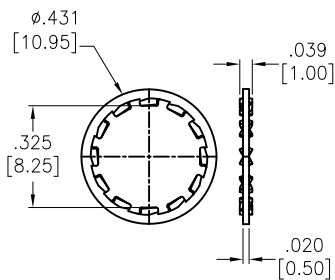
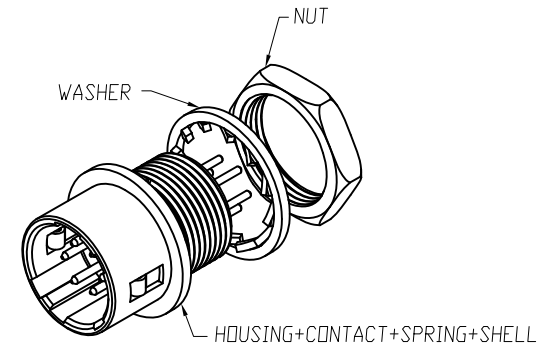
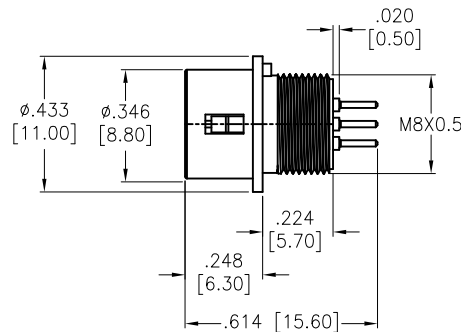
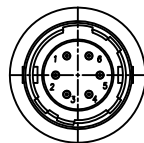

WASHER

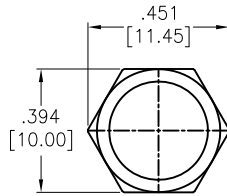

NUT

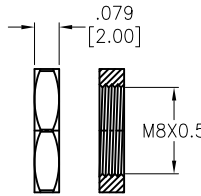

SD-PNNXX-MMLRH-P00-000

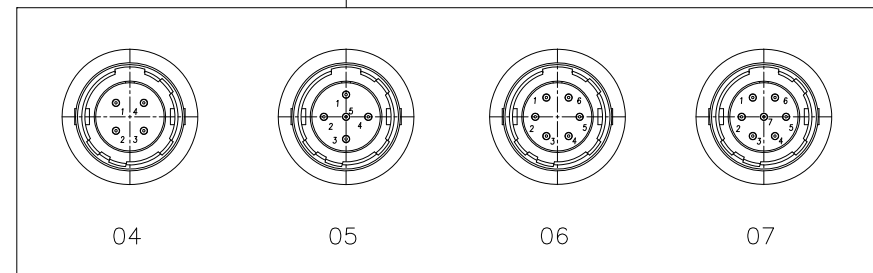

SPECIFICATIONS:

Material:
Housing: Nylon 46, rated UL 94V-0, Color: Black
Contacts: Brass, Gold Flash over Nickel
Shell: Zinc Alloy, Nickel plated
Spring: Stainless Steel
Washer: Phosphor Bronze, Nickel plated
Nut: Brass, Nickel plated
Environmental:
Lead free, RoHS compliant



UNLESS OTHERWISE SPECIFIED
ALL DIMENSIONS ARE INCHES [MM]
TOLERANCES: EXCEPT AS NOTED
INCHES HOLES
.X ± .10 Ø.X ± .10
.XX ± .020 Ø.XX ± .015
.XXX ± .015 Ø.XXX ± .010

ADAM TECH
INTERCONNECTS
909 Rahway Avenue,
Union, NJ 07083
Phone: 908-687-5000
Fax: 908-687-5710

APPROVALS		DATE
DRAWN	HR	11/23/18
CHECKED	AC	11/23/18
APPROVED		

TITLE WATERPROOF CONNECTOR, MALE DIN, REAR PANEL, SHELL LOCK TYPE, STR PCB			
SIZE X	PART NO. SD-PNNXX-MMLRH-P00-000	REV. -	
REF: S00200T	SCALE: NTS	SHEET 1 OF 1	

6

5

4

3

2

1