

AC Current Transducer APR-B10

Split-core transducer for the electronic measurement AC current (all waveforms), with galvanic separation between the primary circuit and the secondary circuit. Switch selectable measuring ranges and true RMS 0-5 V and 0-10 V switch selectable voltage output.

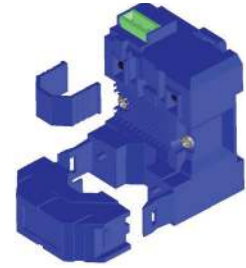

$$I_{PN} = 10 \dots 400 \text{ A}$$



Electrical data			
Primary nominal current I_{PN} (At RMS)	Output voltage (Analog) U_{out} (V DC)	Types	RoHS since date code
10, 25, 50	0-5 or 0-10	APR 50 B10	46184
50, 75, 100	0-5 or 0-10	APR 100 B10	46304
100, 150, 200	0-5 or 0-10	APR 200 B10	46194
200, 300, 400	0-5 or 0-10	APR 400 B10	47150

U_C	Supply voltage	+24 ±5 %	V DC
R_L	Load resistance	≥ 10	kΩ
U_{SL}	Output voltage limitation (0-10 V)	14	V
U_{SL}	Output voltage limitation (0-5 V)	7	V
I_C	Maximum current consumption	< 30	mA
\hat{I}_{Pmax}	Primary withstand peak current (maximum)	no limitation	

Accuracy - Dynamic performance data			
ϵ	Error @ I_{PN} , $T_A = 25 \text{ °C}$ (excluding offset)	< ±1	% of I_{PN}
ϵ_L	Linearity error (0 ... ± I_{PN})	< ±0.5	% of I_{PN}
U_{OE}	Electrical offset voltage @ $T_A = 25 \text{ °C}$	< ±0.5	% of I_{PN}
TCU_{OE}	Temperature coefficient of U_{OE}	±1	mV/K
TCU_{out}	Temperature coefficient of U_{out} (% of reading)	±0.1	%/K
t_{D90}	Delay time to 90 % of the final output value for I_{PN} step	< 400	ms
BW	Frequency bandwidth (±1 %)	30 ... 6000	Hz

General data			
T_A	Ambient operating temperature	-20 ... +60	°C
T_{Ast}	Ambient storage temperature	-20 ... +85	°C
RH	Relative Humidity (non-condensing) ¹⁾	≤ 85	%
	Altitude above sea level (indoor use only)	2000	m
m	Mass	90	g
IPxx	Protection degree	IP 20	

Note: ¹⁾ Long-term exposure to high humidity environment may affect to product reliability.

Features

- VFD and SCR waveforms current measurement
- True RMS output (average)
- Split-core type
- 0-5 V DC and 0-10 V DC switch selectable voltage output
- DIN rail or Panel mounting
- Switch selectable measuring ranges
- Insulating plastic case recognized according to UL 94-V0.

Advantages

- Large aperture for cable up to Ø 18 mm
- High insulation between primary and secondary circuits
- Eliminates insertion loss
- Easy installation.

Applications

- **VFD Controlled Loads:**
VFD output indicates how the motor and attached load are operating.
- **SCR Controlled Loads:**
Accurate measurement of phase angle fired or burst fired (time proportioned) SCRs. Current measurement gives faster response than temperature measurement.
- **Switching Power Supplies and Electronic Ballasts:**
True rms sensing is the most accurate way to measure power supply or ballast input power.

Application domains

- Energies
- Automation.

Current Transducer APR-B10

Insulation coordination

U_{Nm}	Rated insulation RMS voltage ¹⁾ with IEC 61010-1 standards and following conditions: - Reinforced insulation - Over voltage category CAT III - Pollution degree PD2	300	V
U_d	RMS voltage for AC insulation test ²⁾ 50 Hz, 1 min	4.13	kV
U_t	Partial discharge test voltage ($q_m < 10$ pC)	1.5	kV
U_{Ni}	Impulse withstand voltage 1.2/50 μ s	6.1	kV
d_{Cp}	Creepage distance	5.5	mm
d_{Cl}	Clearance ³⁾	5.5	mm
CTI	Comparative tracking index (Group I)	600	

Notes: ¹⁾ If insulated cable is used for the primary circuit, the voltage category could be improved according to the insulation coordination given by the cable manufacturer.

For example:

Cable insulation (primary)	Category
HAR 05	600 V CAT III
HAR 07	1000 V CAT III

²⁾ Between primary (completely filling the primary aperture) and secondary.

³⁾ Insulation distance between primary and secondary may be reduced at actual installation depending on type and shape of primary conductor. In such case, it is highly recommended to use insulated cable in order to maintain required insulation voltage.

Current Transducer APR-B10

Safety and warning notes

In order to guarantee safe operation of the transducer and to be able to make proper use of all features and functions, please read these instructions thoroughly! Safe operation can only be guaranteed if the transducer is used for the purpose it has been designed for and within the limits of the technical specifications. Ensure you get up-to-date technical information that can be found in the latest associated datasheet under www.lem.com.



Caution! Risk of danger

Ignoring the warnings can lead to serious injury and/or cause damage!

The electric measuring transducer may only be installed and put into operation by qualified personnel that have received an appropriate training.

The corresponding national regulations shall be observed during installation and operation of the transducer and any electrical conductor.

The transducer shall be used in electric/electronic equipment with respect to applicable standards and safety requirements and in accordance with all the related systems and components manufacturer' operating instructions.



Caution, Risk of electrical shock

When operating the transducer, certain parts of the module may carry hazardous live voltage (eg. primary conductor, power supply).

The user shall ensure to take all measures necessary to protect against electrical shock. The transducer is a build-in device containing conducting parts that shall not be accessible after installation.

A protective enclosure or additional insulation barrier may be necessary.

The transducer shall not be put into operation if the jaw opening is open (split core version) or the installation is not completed.

Installation and maintenance shall be done with the main power supply disconnected except if there are no hazardous live parts in or in close proximity to the system and if the applicable national regulations are fully observed.

Safe and trouble-free operation of this transducer can only be guaranteed if transport, storage and installation are carried out correctly and operation and maintenance are carried out with care.

Dimensions APR-B10 (in mm)

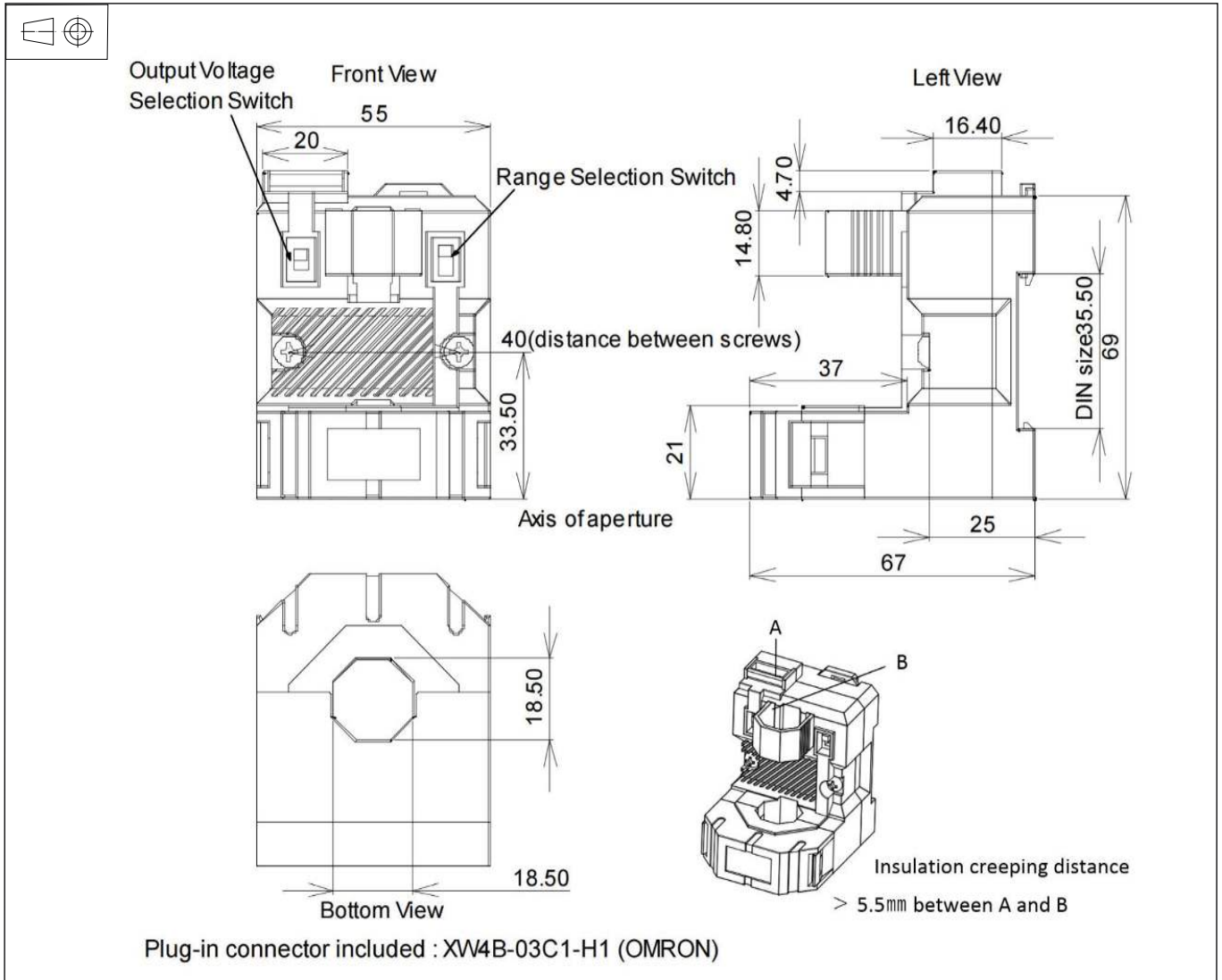

0-5, 10 V Selectable

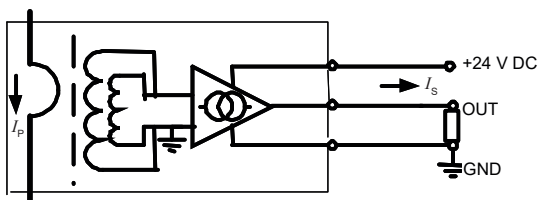
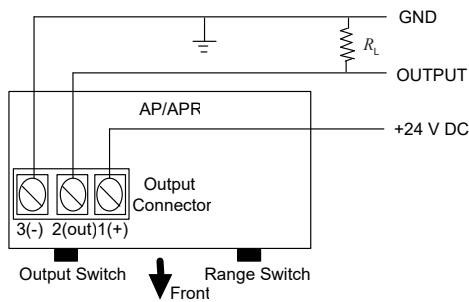

Connections

- Wires up to \varnothing 2 mm
- Female connector provided (spring terminal blocks)
- User-friendly spring-cage connection for no-tool direct conductor connection

Mechanical characteristics

- General tolerance ± 1 mm
 - Primary aperture \varnothing 18.5 mm
 - Panel mounting 2 holes \varnothing 4 mm
 - Distance between holes 40 mm
- For panel mounting, replace M4 screws by new one (not supplied) with appropriate length to panel's thickness.