

DO NOT SCALE FROM THIS PRINT

DESIGNED & DIMENSIONED IN MILLIMETERS [INCHES]

MMCX7-P-P-XX-ST-TH1

TABLE 1			
ITEM	COMPONENT	-HF	-GF
1	SHELL	GRF7-P-P-F-ST-TH1-SHL	
2	PIN	GRF7-P-P-H-ST-TH1-PIN	GRF7-P-P-G-ST-TH1-PIN
3	INSULATOR	GFR7-P-P-ST-TH1-INS	

TERMINATION
-TH1: THROUGH HOLE

ORIENTATION
-ST: STRAIGHT

GENDER
-P: PLUG

TYPE
-P: PCB

PLATING SPECIFICATION
-HF: 30μ" GOLD CENTER CONTACT, 3μ" GOLD OUTER CONTACT
-GF: 10μ" GOLD CENTER CONTACT, 3μ" GOLD OUTER CONTACT (SEE TABLE 1)

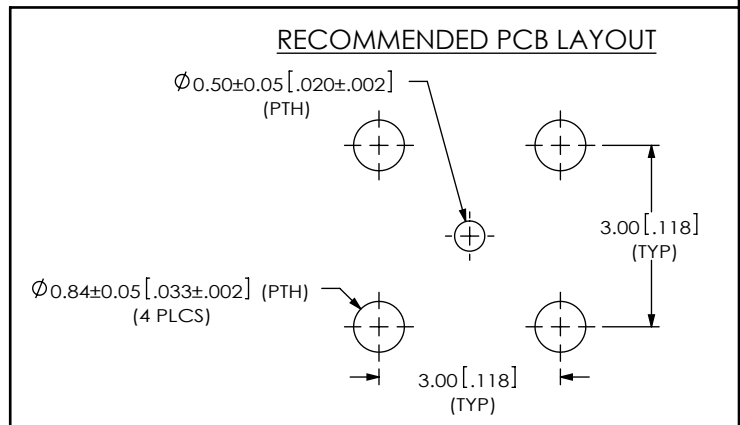
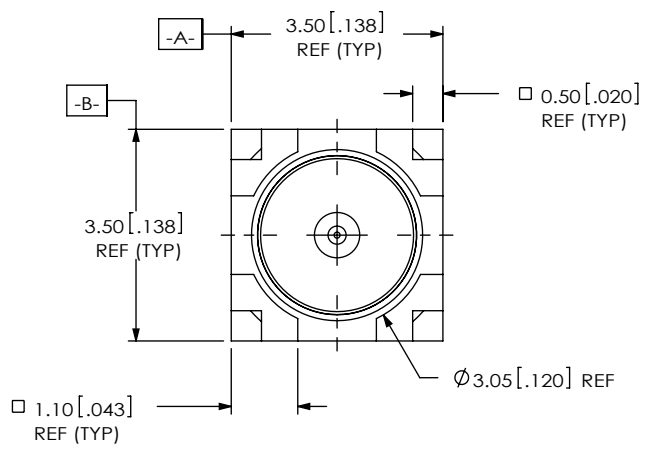
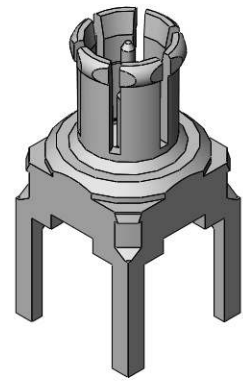
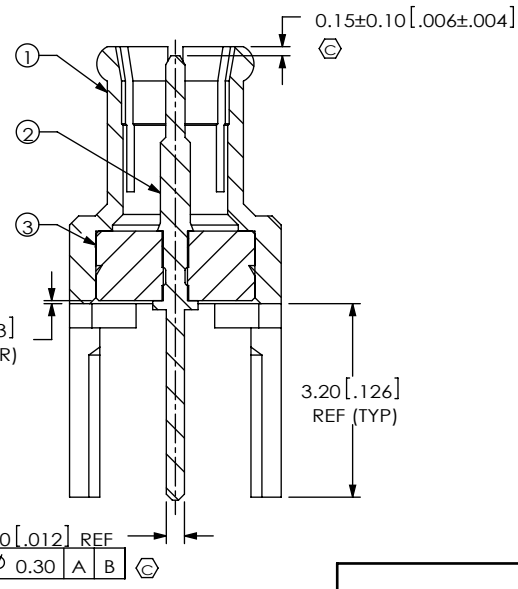
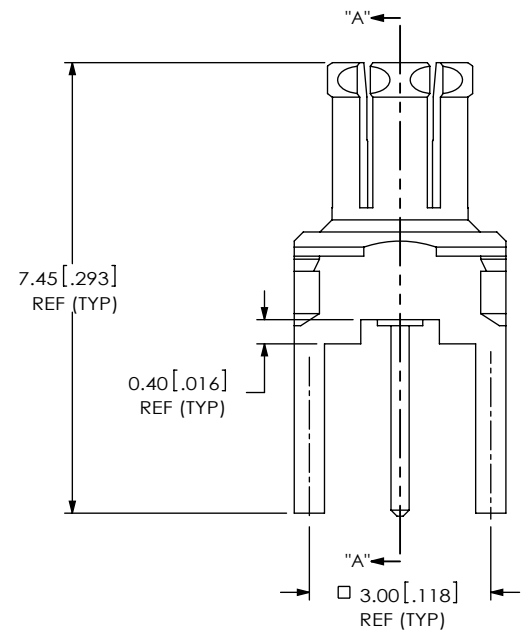

NOTES:

- ⊕ REPRESENTS A CRITICAL DIMENSION.
- MINIMUM PUSHOUT FORCE FOR INSULATOR: 22.24N [5.0 LBS].
- MINIMUM PUSHOUT FORCE FOR CENTER CONTACT: 11.12N [2.5 LBS].
- PRODUCT TO BE PACKAGED PER PACKING STANDARD CO-HD-WI-3040-M. TRAY: TY-SMA001-1 COVER: TY-SMA001-2 200 PARTS PER TRAY (2 PARTS PER POCKET)

UNLESS OTHERWISE SPECIFIED, DIMENSIONS ARE IN MILLIMETERS [INCHES]. TOLERANCES ARE:
DECIMALS ANGLES
X.X: ±0.3 [.01] 5°
X.XX: ±0.13 [.005]
X.XXX: ±0.051 [.0020]

PROPRIETARY NOTE
THIS DOCUMENT CONTAINS INFORMATION CONFIDENTIAL AND PROPRIETARY TO SAMTEC, INC. AND SHALL NOT BE REPRODUCED OR TRANSFERRED TO OTHER DOCUMENTS OR DISCLOSED TO OTHERS OR USED FOR ANY PURPOSE OTHER THAN THAT WHICH IT WAS OBTAINED WITHOUT THE EXPRESSED WRITTEN CONSENT OF SAMTEC, INC.



520 PARK EAST BLVD. NEW ALBANY, IN 47150
PHONE: 812-944-6733 FAX: 812-948-5047
e-Mail: info@SAMTEC.com code 55322

MATERIAL: DO NOT SCALE DRAWING SHEET SCALE: 8:1
SHELL: BeCu
PIN: BRASS
INSULATOR: PTFE

DESCRIPTION: MMCX STRAIGHT THROUGH HOLE, PLUG - 75 OHM
DWG. NO.

MMCX7-P-P-XX-ST-TH1

BY: ALVINW 10/08/2011 SHEET 1 OF 2

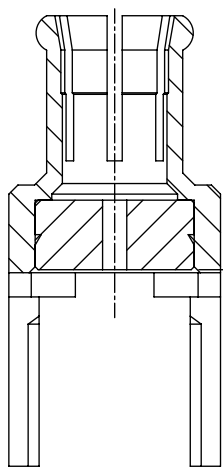

⊕
 $0.05 \pm 0.08 [.002 \pm .003]$
 (SHELL TO INSULATOR)

IN PROCESS 1
 INSERT INSULATOR

PROPRIETARY NOTE

THIS DOCUMENT CONTAINS INFORMATION CONFIDENTIAL AND PROPRIETARY TO SAMTEC, INC. AND SHALL NOT BE REPRODUCED OR TRANSFERRED TO OTHER DOCUMENTS OR DISCLOSED TO OTHERS OR USED FOR ANY PURPOSE OTHER THAN THAT WHICH IT WAS OBTAINED WITHOUT THE EXPRESSED WRITTEN CONSENT OF SAMTEC, INC.

DO NOT SCALE DRAWING

SHEET SCALE: 8:1



520 PARK EAST BLVD, NEW ALBANY, IN 47150
 PHONE: 812-944-6733 FAX: 812-948-5047
 e-Mail: info@SAMTEC.com code 55322

DESCRIPTION:
 MMCX STRAIGHT THROUGH HOLE, PLUG - 75 OHM

DWG. NO.
MMCX7-P-P-XX-ST-TH1

BY: ALVINW 10/08/2011 SHEET 2 OF 2