

Features

- Very High Transmitting Frequency Accuracy Compared to SAW Solutions (Enables Receivers at Lower Bandwidth than With SAW Resonators)
- Lower Cost than the Usual Discrete Solutions Using SAW and Transistors
- Supply Voltage 2.2V to 4.0V in the Temperature Range of -40°C to 85°C
- XTO Output for Clocking the Microcontroller, Thereby, Together with the ATAR090 or ATAR890, Resulting in the Optimum System Cost-effectiveness
- One-chip Solution With Minimum External Circuitry
- Single-ended Open-collector Output (Same Antennas Can Be Used as in Discrete Solutions, Simpler Matching of Magnetic Loop Antennas)
- ESD Protection According to MIL-STD 883 (4 KV HBM) Except Pins XTO1, XTO2, ANT and LF
- Very Small SSO16 Package, Pitch 0.635, 150 mil

1. Description

The ATA2745 is a PLL transmitter IC which has been developed especially for the demands of RF low-cost data transmission systems at data rates up to 20 kBaud.

The transmitting frequency range is 310 MHz to 440 MHz. It can be used in ASK systems. The main applications of the ATA2745 are in the areas of outside temperature metering, socket control, garage door openers, consumption metering, light/fan or air-conditioning controls, jalousies, wireless keyboards, and various other consumer market applications.



UHF ASK Transmitter

ATA2745



Figure 1-1. System Block Diagram

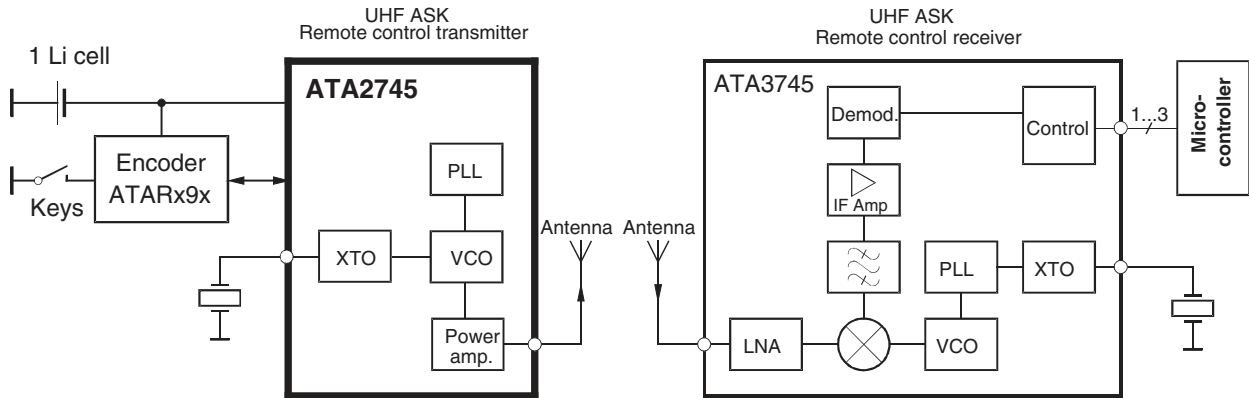
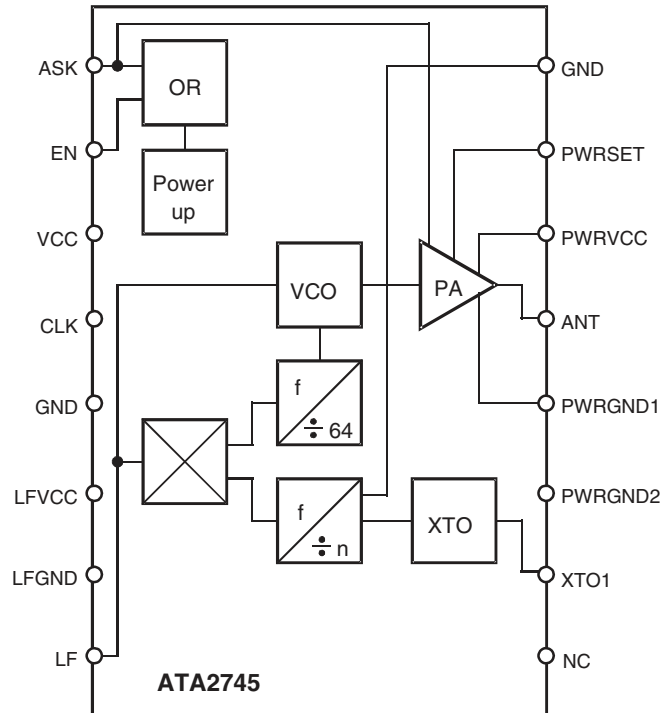

Figure 1-2. Block Diagram



2. Pin Configuration

Figure 2-1. Pinning SSO16

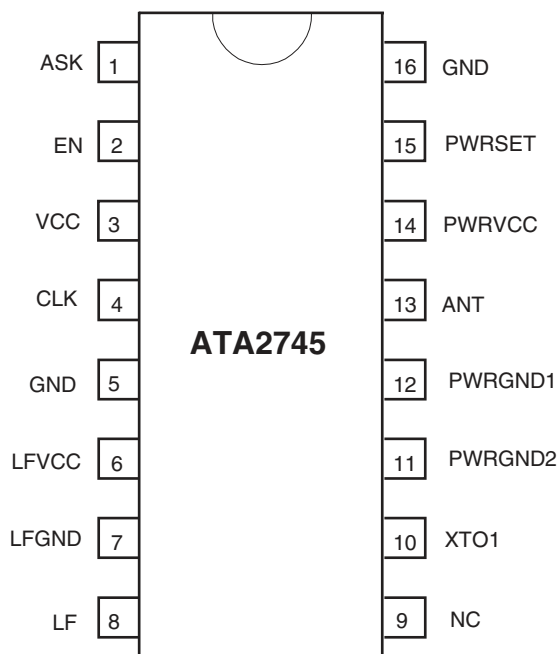

Table 2-1. Pin Description

Pin	Symbol	Function
1	ASK	Modulation input ASK
2	EN	Enable input
3	VCC	Supply voltage
4	CLK	Clock output
5	GND	Ground
6	LFVCC	Supply voltage VCO
7	LFGND	VCO ground
8	LF	Circuit PLL loop
9	NC	Not connected
10	XTO1	Connection for crystal
11	PWRGND2	Power GND2
12	PWRGND1	Power GND1
13	ANT	RF output
14	PWRVCC	Supply voltage power amplifier
15	PWRSET	Applied to VCC
16	GND	Ground

3. General Description

The fully integrated VCO and the single-ended open-collector output allow particularly simple, low-cost RF miniature transmitters to be assembled. The single-ended output enables a considerably simplified adaptation of both a magnetic loop antenna of any form or a $\lambda / 4$ antenna. This is because the load impedance must not be balanced as would be the case with a differential output.

The XTO's frequency can be selected to be either 13.56 MHz or 9.844 MHz (USA). At these frequencies, crystals have a very fast start-up time (< 1.5 ms), whereby a wait time of 5 ms to 10 ms is required until the transmitter IC is locked. This means that the processor does not need to poll a lock detect output.

4. Functional Description

4.1 ASK Transmission

The ATA2745 is activated by $EN = V_S$. V_{ASK} must remain 0V for 5 ms, then the output power can be modulated by means of pin ASK. V_{EN} remains equal to V_S during the transmission of the message. The ASK input activates the power amplifier and the PLL.

4.2 Take-over of the Clock Pulse in the Microcontroller

The clock of the crystal oscillator can be used for clocking the microcontroller. The ATAR090 and ATAR890 have the special feature of starting with an integrated RC oscillator to switch on the ATA2745 with $V_{EN} = V_S$. 5 ms later, the 3.39-MHz clock frequency is present, so that the message can be sent with crystal accuracy.

5. Application Circuit

The following component values are recommendations for a typical application. C_4 , C_5 , and C_6 are block capacitors. The values of these capacitors depend on the board layout. $C_4 = 1$ nF, $C_5 = 1$ nF, and $C_6 = 22$ nF are typically used here. For C_5 , the impedance between $f = 100$ MHz and $f = 1$ GHz should be as low as possible.

C_{Loop1} and C_{Loop2} are selected so that the antenna oscillates in resonance and the matching to the appropriate impedance transformation is possible.

L_{Feed} is an inductor for the antenna's DC current supply. A typical value is $L_{Feed} = 220$ nH. L_{Feed} can be either printed on the PC board or be a discrete component.

5.1 Output Power Measurement

The following output network (Figure 5-1 on page 5) can be used for output power evaluation, the exact values of L_{10} and C_{10} are dependent on the layout.

L_{10} and C_{10} form the transformation network to adopt the output impedance of the IC to 50Ω . The following table shows the values for an output power of 2 mW and an $R_{PWRSET} = 1.2\text{ k}\Omega$

Table 5-1. Transformation Network

f [MHz]	C10 [pF]	L10 [nH]	Z _{Load-opt} [Ω]
315	2.7	56	260 + j330
433.92	1.8	33	185 + j268

Figure 5-1. Measurement Output Network

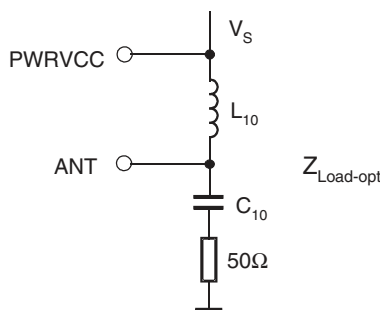
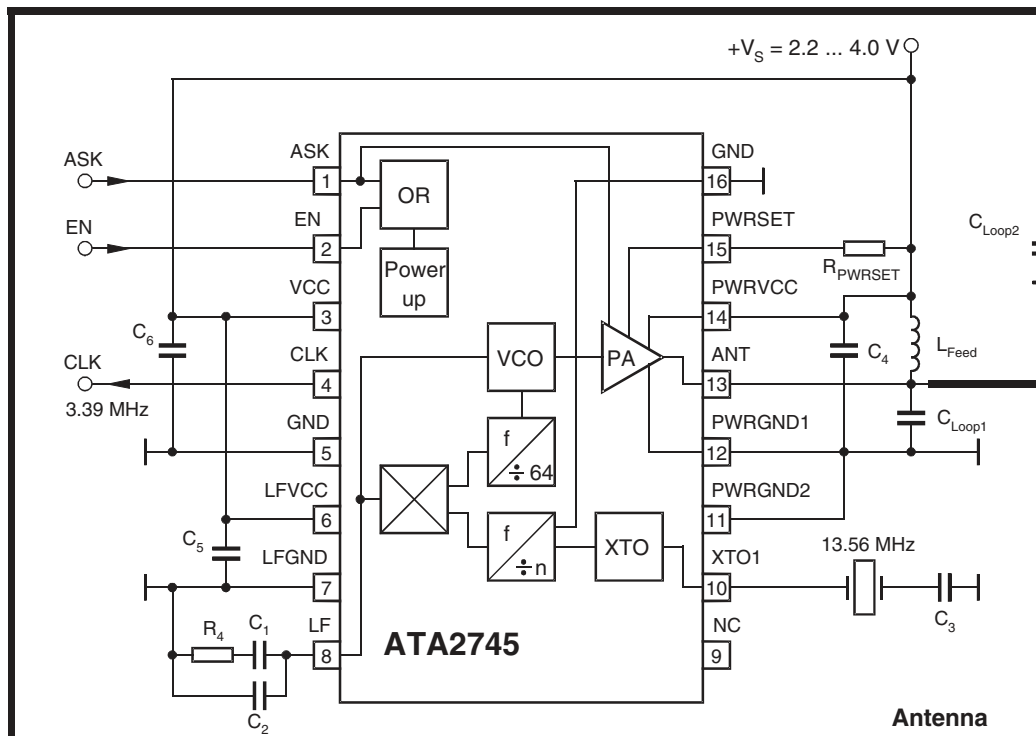

Figure 5-2. Application Circuit



6. Absolute Maximum Ratings

Stresses beyond those listed under “Absolute Maximum Ratings” may cause permanent damage to the device. This is a stress rating only and functional operation of the device at these or any other conditions beyond those indicated in the operational sections of this specification is not implied. Exposure to absolute maximum rating conditions for extended periods may affect device reliability.

Parameters	Symbol	Min.	Max.	Unit
Supply voltage	V_S		6	V
Power dissipation	P_{tot}		250	mW
Junction temperature	T_j		150	°C
Storage temperature	T_{stg}	-55	125	°C
Ambient temperature	T_{amb}	-40	85	°C

Electrostatic sensitive device.
Observe precautions for handling.



7. Thermal Resistance

Parameters	Symbol	Value	Unit
Junction ambient	R_{thJA}	180	K/W

8. Electrical Characteristics

All parameters are referred to GND (pin 5), $V_S = 3V$, $T_{amb} = 25^\circ C$, unless otherwise specified

The possible operating ranges refer to different circuit conditions: $V_S = 2.2V$ to $4.0V$ at $T_{amb} = -40^\circ C$ to $+85^\circ C$

Parameters	Test Conditions	Symbol	Min.	Typ.	Max.	Unit
Supply current (power down)	$V_{ASK}, V_{FSK} \leq 0.3V, V_S < 3.6V$	I_{Soff}		2	10	μA
Supply current (power up, output OFF)	$V_{ASK} = GND, V_{EN} = V_S, V_S = 3V$	I_{SOn}		4.7	6.2	mA
Supply current (power up, output ON)	$V_{ASK} = V_S, V_S = 3V, R_{PWRSET} = 1.2 k\Omega$	$I_{Stransmit}$		10	12.5	mA
Output power	$V_S = 3V, T_{amb} = 25^\circ C, f = 433.92 MHz$ $R_{PWRSET} = 1.2 k\Omega$	P_{Ref}	1	3	5	dBm
Output power variation for $f = 315 MHz$ compared to $f = 433.92 MHz$	$f = 315 MHz$ $P_{out} = P_{Ref} + \Delta P_{Ref}$	ΔP_{Ref}		1.5		dB
Maximum peak output antenna voltage	At $P_{out} = 2.0 mW$, the load impedance must be selected to meet the V_{out} maximum requirement, the supply current is not dependent on the load impedance tolerance	V_{outmax}		$V_S - 0.7V$		$V_{(peak)}$
Spurious emission	$f_o \pm (n \times f_{PC})$ where $f_{PC} = 6.78 MHz$ Load capacitance at CLK $\leq 3 pF$ $f = 230 MHz$ to $470 MHz$ $f < 230 MHz, f > 470 MHz$	Em Em			-40 -58	dB dB
Oscillator frequency XTO	Crystal frequency = 13.56 MHz	f_{XTO}	13.56 – 30 ppm	13.56	13.56 + 30 ppm	MHz

8. Electrical Characteristics (Continued)

All parameters are referred to GND (pin 5), $V_S = 3V$, $T_{amb} = 25^\circ C$, unless otherwise specified

The possible operating ranges refer to different circuit conditions: $V_S = 2.2V$ to $4.0V$ at $T_{amb} = -40^\circ C$ to $+85^\circ C$

Parameters	Test Conditions	Symbol	Min.	Typ.	Max.	Unit
Loop bandwidth	For best LO noise Loop filter components: $C_2 = 3.9 \text{ nF}$, $C_1 = 15 \text{ nF}$, $R_4 = 220\Omega$	B_{Loop}		100		kHz
Phase noise PLL	Referring to the phase comparator $f_{PC} = 6.78 \text{ MHz}$	PN_{PLL}		-111	-105	dBc/Hz
Phase noise VCO	At 1 MHz At 36 MHz	PN_{VCO} PN_{VCO}		-90 -122		dBc/Hz
Frequency range of the VCO		f_{VCO}	310		440	MHz
Clock output (CMOS microcontroller compatible)		Clk_{out}		$f_{out} / 128$		MHz
Load capacitance at CLK		C_{CLK}			10	pF
Series resonance R of the crystal	$f_{XTO} = 13.56 \text{ MHz}$ $f_{XTO} = 9.84 \text{ MHz}$	R_s R_s			80 100	Ω
ASK modulation frequency rate	Duty cycle of the modulation signal = 50%	f_{modASK}	0		20	kHz
CLK output - Output current Low - Output current Low - Output current High - Output current High	$V_{CLK} = 0.2 \times V_S$ $V_{CLK} = 0.3 \times V_S$ $V_{CLK} = 0.8 \times V_S$ $V_{CLK} = 0.7 \times V_S$	I_{ol} I_{ol} I_{oh} I_{oh}	150 200 -150 -200		100	μA μA μA μA
ASK input - Low level input voltage - High level input voltage - Input current High		V_{ASKl} V_{ASKh} I_{ASKh}	1.7		0.3 140	V V μA
Enable ASK - Low level input voltage - High level input voltage - Input current High		V_{EN} V_{FSKl} V_{FSKh} I_{FSKh}	1.7		0.3 140	V V μA

9. Ordering Information

Extended Type Number	Package	Remarks
ATA2745M-TCQY	SS016	Taped and reeled, Pb-free

10. Package Information

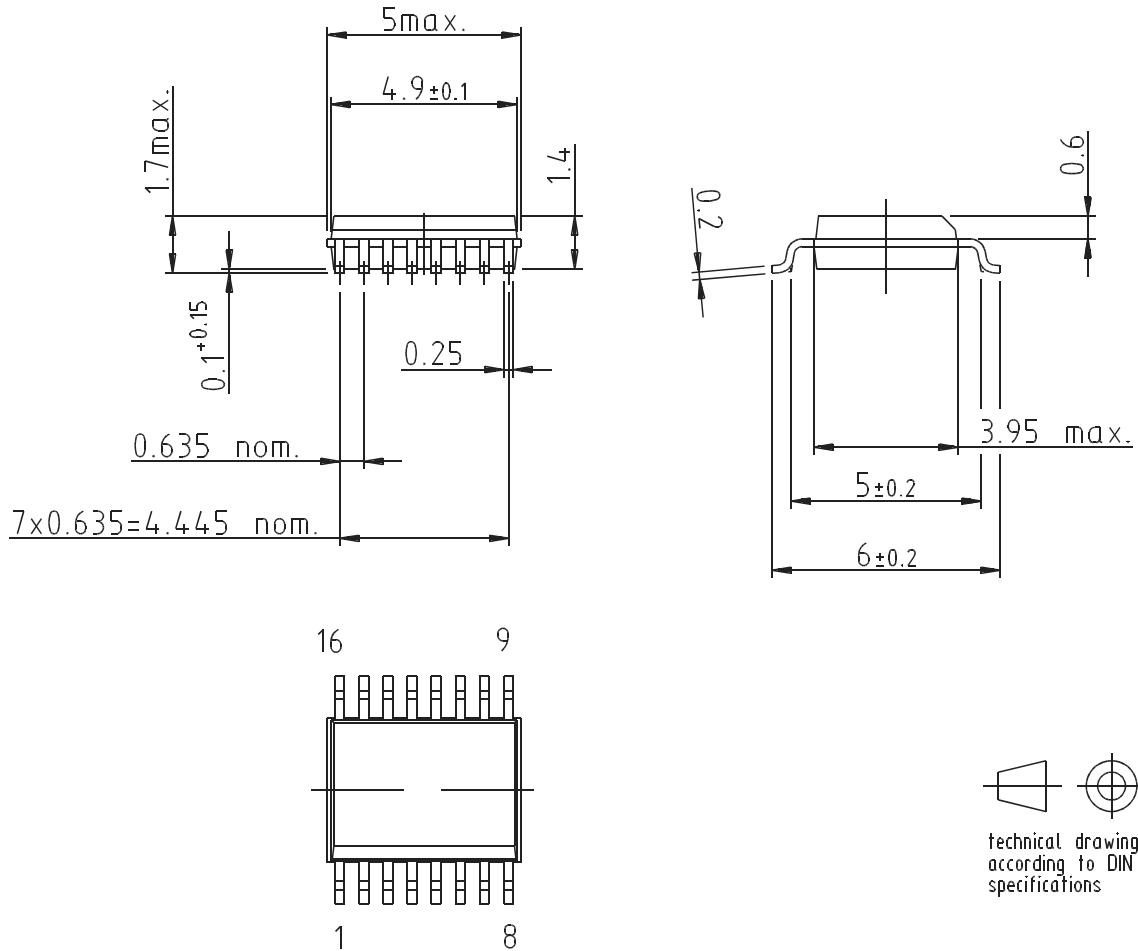

Drawing refers to following types: SS016
 Package acc. JEDEC MO 137 AB

11. Revision History

Please note that the following page numbers referred to in this section refer to the specific revision mentioned, not to this document.

Revision No.	History
4898B-RKE-08/06	<ul style="list-style-type: none">• Put datasheet in a new template• Section 9 "Ordering Information" on page 8 changed



Atmel Corporation

2325 Orchard Parkway
San Jose, CA 95131, USA
Tel: 1(408) 441-0311
Fax: 1(408) 487-2600

Regional Headquarters

Europe

Atmel Sarl
Route des Arsenaux 41
Case Postale 80
CH-1705 Fribourg
Switzerland
Tel: (41) 26-426-5555
Fax: (41) 26-426-5500

Asia

Room 1219
Chinachem Golden Plaza
77 Mody Road Tsimshatsui
East Kowloon
Hong Kong
Tel: (852) 2721-9778
Fax: (852) 2722-1369

Japan

9F, Tonetsu Shinkawa Bldg.
1-24-8 Shinkawa
Chuo-ku, Tokyo 104-0033
Japan
Tel: (81) 3-3523-3551
Fax: (81) 3-3523-7581

Atmel Operations

Memory

2325 Orchard Parkway
San Jose, CA 95131, USA
Tel: 1(408) 441-0311
Fax: 1(408) 436-4314

Microcontrollers

2325 Orchard Parkway
San Jose, CA 95131, USA
Tel: 1(408) 441-0311
Fax: 1(408) 436-4314

La Chantrerie
BP 70602
44306 Nantes Cedex 3, France
Tel: (33) 2-40-18-18-18
Fax: (33) 2-40-18-19-60

ASIC/ASSP/Smart Cards

Zone Industrielle
13106 Rousset Cedex, France
Tel: (33) 4-42-53-60-00
Fax: (33) 4-42-53-60-01

1150 East Cheyenne Mtn. Blvd.
Colorado Springs, CO 80906, USA
Tel: 1(719) 576-3300
Fax: 1(719) 540-1759

Scottish Enterprise Technology Park
Maxwell Building
East Kilbride G75 0QR, Scotland
Tel: (44) 1355-803-000
Fax: (44) 1355-242-743

RF/Automotive

Theresienstrasse 2
Postfach 3535
74025 Heilbronn, Germany
Tel: (49) 71-31-67-0
Fax: (49) 71-31-67-2340

1150 East Cheyenne Mtn. Blvd.
Colorado Springs, CO 80906, USA
Tel: 1(719) 576-3300
Fax: 1(719) 540-1759

Biometrics/Imaging/Hi-Rel MPU/ High-Speed Converters/RF Datacom

Avenue de Rochepleine
BP 123
38521 Saint-Egreve Cedex, France
Tel: (33) 4-76-58-30-00
Fax: (33) 4-76-58-34-80

Literature Requests

www.atmel.com/literature

Disclaimer: The information in this document is provided in connection with Atmel products. No license, express or implied, by estoppel or otherwise, to any intellectual property right is granted by this document or in connection with the sale of Atmel products. **EXCEPT AS SET FORTH IN ATMEL'S TERMS AND CONDITIONS OF SALE LOCATED ON ATMEL'S WEB SITE, ATMEL ASSUMES NO LIABILITY WHATSOEVER AND DISCLAIMS ANY EXPRESS, IMPLIED OR STATUTORY WARRANTY RELATING TO ITS PRODUCTS INCLUDING, BUT NOT LIMITED TO, THE IMPLIED WARRANTY OF MERCHANTABILITY, FITNESS FOR A PARTICULAR PURPOSE, OR NON-INFRINGEMENT. IN NO EVENT SHALL ATMEL BE LIABLE FOR ANY DIRECT, INDIRECT, CONSEQUENTIAL, PUNITIVE, SPECIAL OR INCIDENTAL DAMAGES (INCLUDING, WITHOUT LIMITATION, DAMAGES FOR LOSS OF PROFITS, BUSINESS INTERRUPTION, OR LOSS OF INFORMATION) ARISING OUT OF THE USE OR INABILITY TO USE THIS DOCUMENT, EVEN IF ATMEL HAS BEEN ADVISED OF THE POSSIBILITY OF SUCH DAMAGES.** Atmel makes no representations or warranties with respect to the accuracy or completeness of the contents of this document and reserves the right to make changes to specifications and product descriptions at any time without notice. Atmel does not make any commitment to update the information contained herein. Unless specifically provided otherwise, Atmel products are not suitable for, and shall not be used in, automotive applications. Atmel's products are not intended, authorized, or warranted for use as components in applications intended to support or sustain life.

© 2006 Atmel Corporation. All rights reserved. Atmel®, logo and combinations thereof, Everywhere You Are® and others are registered trademarks or trademarks of Atmel Corporation or its subsidiaries. Other terms and product names may be trademarks of others.