



ANATECH ELECTRONICS INC
RF & Microwave Filters & Products

1390 MHz Ceramic Bandpass Filter

Part Number: AM1390B1312



Electrical specifications

Center Frequency: 1390 MHz
Bandwidth: 50 MHz min
VSWR: 1.5:1
Input / Output Impedance: 50 Ohms
Passband: 1365-1415 MHz
Passband Insertion Loss: 3.0 dB max
Passband Ripple: 0.4 dB max
Rejection: 45 dB min at DC-1200 MHz
Rejection 2: 30 dB min at 1700 MHz
Power Handling: 1 W

Mechanical

Mounting Method: SMT
Dimensions: 18.2 x 14 x 5 mm

Environmental

Operating Temperature: -30°C to 85°C
Storage Temperature: -50°C to +90°C

This product is RoHs compliant.

Outline Drawing:

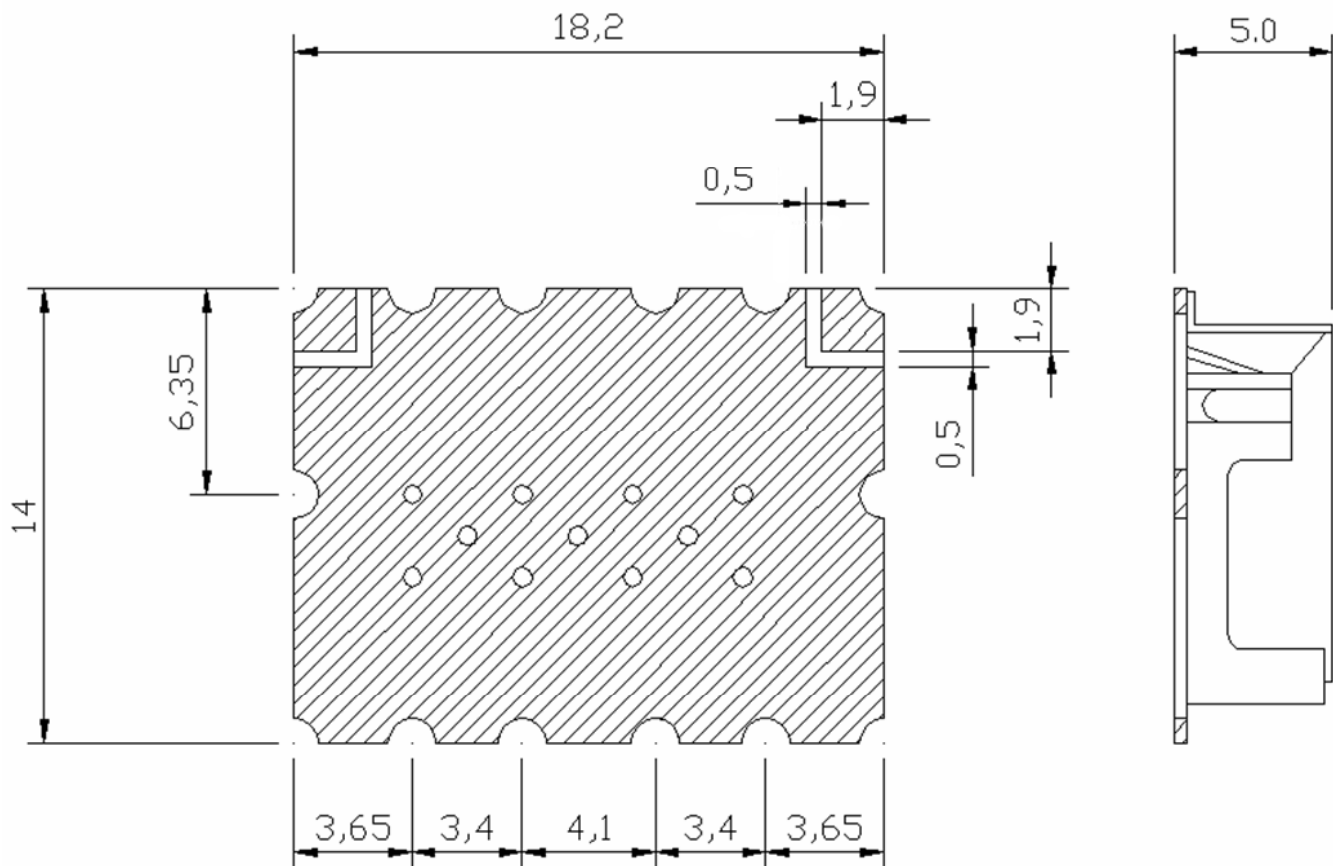

Unit : mm

Tolerance : ± 0.3