

DirectFET™ Power MOSFET

Typical values (unless otherwise specified)

| | | |
|--------------------------|-----------------------|---------------------------|
| V_{DS} | V_{GS} | R_{DS(on)} |
| 60V min | ±20V max | 1.7mΩ @ 10V |
| Q_{g tot} | Q_{gd} | V_{gs(th)} |
| 146nC | 40nC | 2.9V |

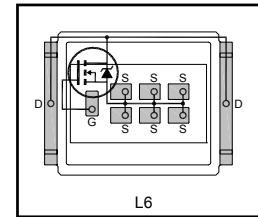

Applications

- [RoHS Compliant, Halogen Free](#) ②
- [Lead-Free \(Qualified up to 260°C Reflow\)](#) ①
- Ideal for High Performance Isolated Converter Primary Switch Socket
- Optimized for Synchronous Rectification
- Low Conduction Losses
- High Cdv/dt Immunity
- Low Profile (<0.7mm)
- [Dual Sided Cooling Compatible](#) ①
- [Compatible with existing Surface Mount Techniques](#) ①
- Industrial Qualified

[Applicable DirectFET Outline and Substrate Outline](#) ①

| | | | | | | | |
|-----------|-----------|--|-----------|-----------|-----------|-----------|-----------|
| SB | SC | | M2 | M4 | L4 | L6 | L8 |
|-----------|-----------|--|-----------|-----------|-----------|-----------|-----------|

Description

The IRF7748L1TRPbF combines the latest HEXFET® Power MOSFET Silicon technology with the advanced DirectFET™ packaging to achieve the lowest on-state resistance in a package that has a footprint smaller than a D2PAK and only 0.7 mm profile. The DirectFET package is compatible with existing layout geometries used in power applications, PCB assembly equipment and vapor phase, infra-red or convection soldering techniques, when [application note AN-1035](#) is followed regarding the manufacturing methods and processes. The DirectFET package allows dual sided cooling to maximize thermal transfer in power systems.

The IRF7748L1TRPbF is optimized for high frequency switching and synchronous rectification applications. The reduced total losses in the device coupled with the high level of thermal performance enables high efficiency and low temperatures, which are key for system reliability improvements, and makes this device ideal for high performance power converters.

Ordering Information

| Base part number | Package Type | Standard Pack | | Orderable Part Number |
|------------------|---------------------|---------------|----------|-----------------------|
| | | Form | Quantity | |
| IRF7748L1TRPbF | DirectFET Large Can | Tape and Reel | 4000 | IRF7748L1TRPbF |

Absolute Maximum Ratings

| | Parameter | Max. | Units |
|---|--|------|-------|
| V _{DS} | Drain-to-Source Voltage | 60 | V |
| V _{GS} | Gate-to-Source Voltage | ±20 | |
| I _D @ T _C = 25°C | Continuous Drain Current, V _{GS} @ 10V (Silicon Limited)④ | 148 | |
| I _D @ T _C = 100°C | Continuous Drain Current, V _{GS} @ 10V (Silicon Limited)④ | 104 | A |
| I _D @ T _A = 25°C | Continuous Drain Current, V _{GS} @ 10V (Silicon Limited)③ | 28 | |
| I _{DM} | Pulsed Drain Current⑤ | 592 | |
| E _{AS} | Single Pulse Avalanche Energy ⑥ | 129 | mJ |
| I _{AR} | Avalanche Current ⑥ | 89 | A |

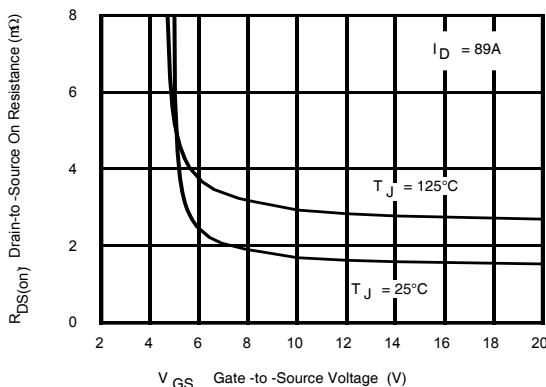

Fig 1. Typical On-Resistance vs. Gate Voltage

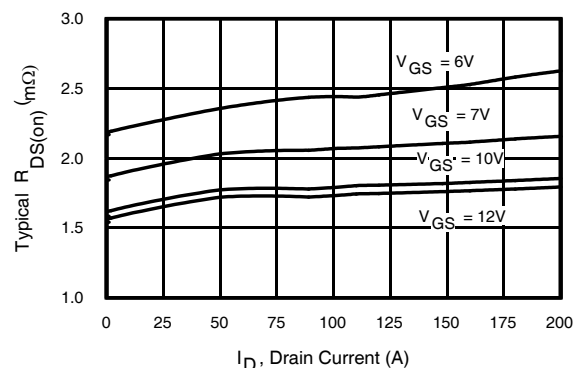

Fig 2. Typical On-Resistance vs. Drain Current

Notes

- ① Click on this section to link to the appropriate technical paper.
- ② Click on this section to link to the DirectFET Website.
- ③ Surface mounted on 1 in. square Cu board, steady state.

- ④ TC measured with thermocouple mounted to top (Drain) of part.
- ⑤ Repetitive rating; pulse width limited by max. junction temperature.
- ⑥ Starting T_J = 25°C, L = 0.033mH, R_G = 50Ω, I_{AS} = 89A.

Static @ T_J = 25°C (unless otherwise specified)

| | Parameter | Min. | Typ. | Max. | Units | Conditions |
|---------------------------------------|---|------|-------|------|-------|--|
| BV _{DSS} | Drain-to-Source Breakdown Voltage | 60 | — | — | V | V _{GS} = 0V, I _D = 250μA |
| ΔBV _{DSS} /ΔT _J | Breakdown Voltage Temp. Coefficient | — | 0.022 | — | V/°C | Reference to 25°C, I _D = 2mA |
| R _{DS(on)} | Static Drain-to-Source On-Resistance | — | 1.7 | 2.2 | mΩ | V _{GS} = 10V, I _D = 89A ⑦ |
| V _{GS(th)} | Gate Threshold Voltage | 2.0 | 2.9 | 4.0 | V | V _{DS} = V _{GS} , I _D = 250μA |
| ΔV _{GS(th)} /ΔT _J | Gate Threshold Voltage Temp. Coefficient | — | -9.9 | — | mV/°C | |
| I _{DSS} | Drain-to-Source Leakage Current | — | — | 20 | μA | V _{DS} = 60V, V _{GS} = 0V |
| | | — | — | 250 | | V _{DS} = 60V, V _{GS} = 0V, T _J = 125°C |
| I _{GSS} | Gate-to-Source Forward Leakage | — | — | 100 | nA | V _{GS} = 20V |
| | Gate-to-Source Reverse Leakage | — | — | -100 | | V _{GS} = -20V |
| g _{fs} | Forward Transconductance | 176 | — | — | S | V _{DS} = 10V, I _D = 89A |
| Q _g | Total Gate Charge | — | 146 | 220 | nC | V _{DS} = 30V V _{GS} = 10V I _D = 89A See Fig.9 |
| Q _{gs1} | Pre- V _{th} Gate-to-Source Charge | — | 31 | — | | |
| Q _{gs2} | Post- V _{th} Gate-to-Source Charge | — | 12 | — | | |
| Q _{gd} | Gate-to-Drain Charge | — | 40 | — | | |
| Q _{godr} | Gate Charge Overdrive | — | 63 | — | | |
| Q _{sw} | Switch Charge (Q _{gs2} + Q _{gd}) | — | 52 | — | nC | V _{DS} = 16V, V _{GS} = 0V |
| Q _{oss} | Output Charge | — | 82 | — | | |
| R _G | Gate Resistance | — | 1.3 | — | Ω | |
| t _{d(on)} | Turn-On Delay Time | — | 19 | — | ns | V _{DD} = 30V, V _{GS} = 10V ⑦ I _D = 89A R _G = 1.8Ω |
| t _r | Rise Time | — | 104 | — | | |
| t _{d(off)} | Turn-Off Delay Time | — | 54 | — | | |
| t _f | Fall Time | — | 77 | — | | |
| C _{iss} | Input Capacitance | — | 8075 | — | pF | V _{GS} = 0V V _{DS} = 50V f = 1.0MHz V _{GS} = 0V, V _{DS} = 1.0V, f = 1.0MHz V _{GS} = 0V, V _{DS} = 48V, f = 1.0MHz |
| C _{oss} | Output Capacitance | — | 1150 | — | | |
| C _{rss} | Reverse Transfer Capacitance | — | 540 | — | | |
| C _{oss} | Output Capacitance | — | 5390 | — | | |
| C _{oss} | Output Capacitance | — | 850 | — | | |

Diode Characteristics

| | Parameter | Min. | Typ. | Max. | Units | Conditions |
|-----------------|--|------|------|------|-------|---|
| I _S | Continuous Source Current (Body Diode) | — | — | 85 | A | MOSFET symbol showing the integral reverse p-n junction diode. |
| I _{SM} | Pulsed Source Current (Body Diode) ⑤ | — | — | 592 | | |
| V _{SD} | Diode Forward Voltage | — | — | 1.3 | V | T _J = 25°C, I _S = 89A, V _{GS} = 0V ⑦ |
| t _{rr} | Reverse Recovery Time | — | 58 | — | ns | T _J = 25°C, I _F = 89A, V _{DD} = 30V |
| Q _{rr} | Reverse Recovery Charge | — | 113 | — | nC | di/dt = 100A/μs ⑦ |

Notes:

⑤ Repetitive rating; pulse width limited by max. junction temperature.

⑦ Pulse width ≤ 400μs; duty cycle ≤ 2%

Absolute Maximum Ratings

| Symbol | Parameter | Max. | Units |
|---------------------------------|----------------------------|--------------|------------------|
| $P_D @ T_C = 25^\circ\text{C}$ | Power Dissipation ④ | 94 | W |
| $P_D @ T_C = 100^\circ\text{C}$ | Power Dissipation ④ | 47 | |
| $P_D @ T_A = 25^\circ\text{C}$ | Power Dissipation ③ | 3.3 | |
| T_P | Peak Soldering Temperature | 270 | $^\circ\text{C}$ |
| T_J | Operating Junction and | -55 to + 175 | |
| T_{STG} | Storage Temperature Range | | |

Thermal Resistance

| Symbol | Parameter | Typ. | Max. | Units |
|---------------|-------------------------|------|------|--------------------|
| R_{qJA} | Junction-to-Ambient ③ | — | 45 | $^\circ\text{C/W}$ |
| R_{qJA} | Junction-to-Ambient ⑧ | 12.5 | — | |
| R_{qJA} | Junction-to-Ambient ⑨ | 20 | — | |
| R_{qJC} | Junction-to-Can ④⑩ | — | 1.6 | |
| $R_{qJA-PCB}$ | Junction-to-PCB Mounted | — | 0.5 | |

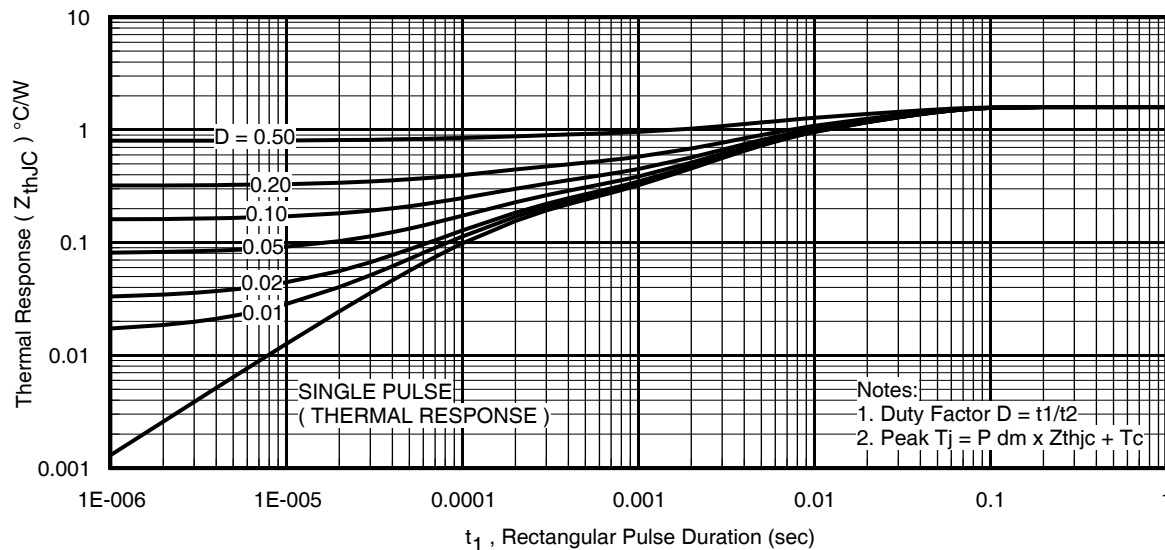
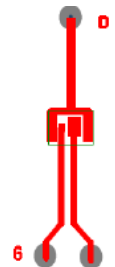
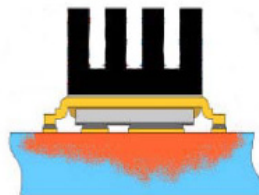
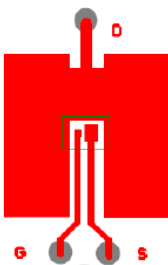

Fig 3. Maximum Effective Transient Thermal Impedance, Junction-to-Case

Notes:

- ③ Surface mounted on 1 in. square Cu board, steady state.
- ④ T_C measured with thermocouple incontact with top (Drain) of part.
- ⑤ Repetitive rating; pulse width limited by max. junction temperature.
- ⑧ Used double sided cooling, mounting pad with large heatsink.
- ⑨ Mounted on minimum footprint full size board with metalized back and with small clip heatsink.
- ⑩ R_θ is measured at T_J of approximately 90°C .



③ Surface mounted on 1 in. square Cu board (still air).

⑨ Mounted on minimum footprint full size board with metalized back and with small clip heatsink (still air)

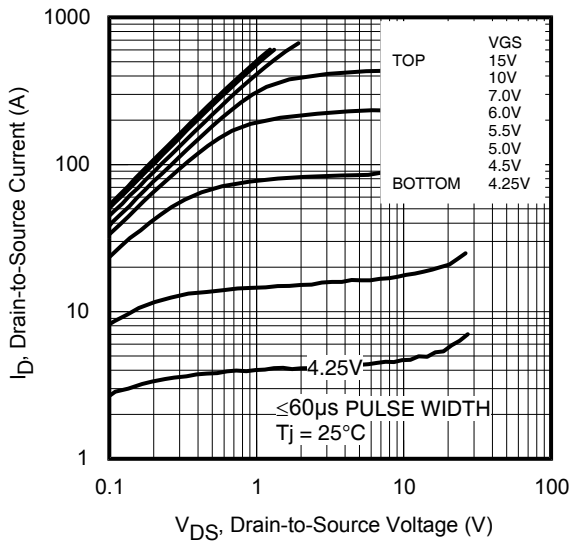
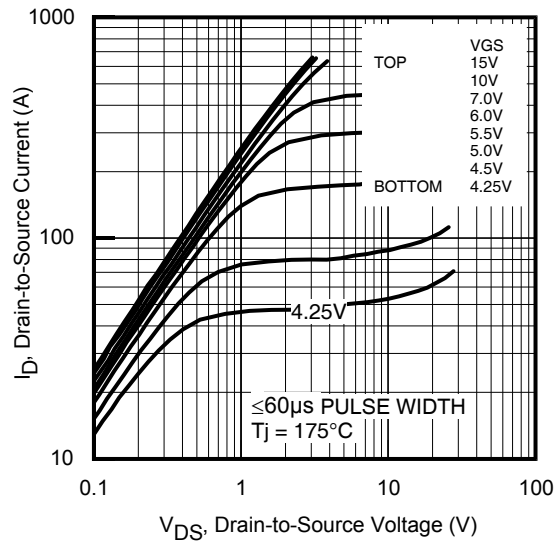
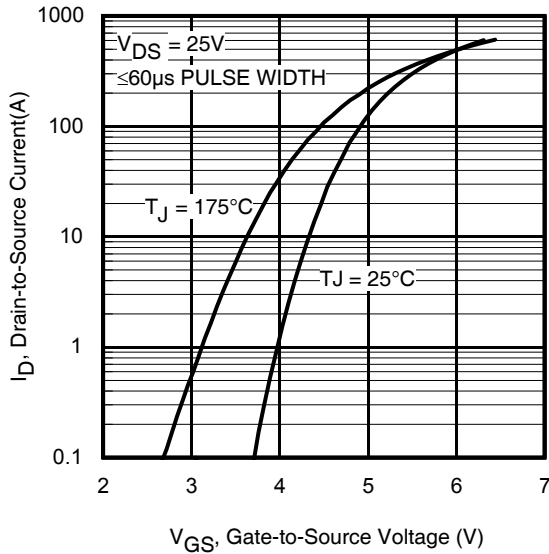
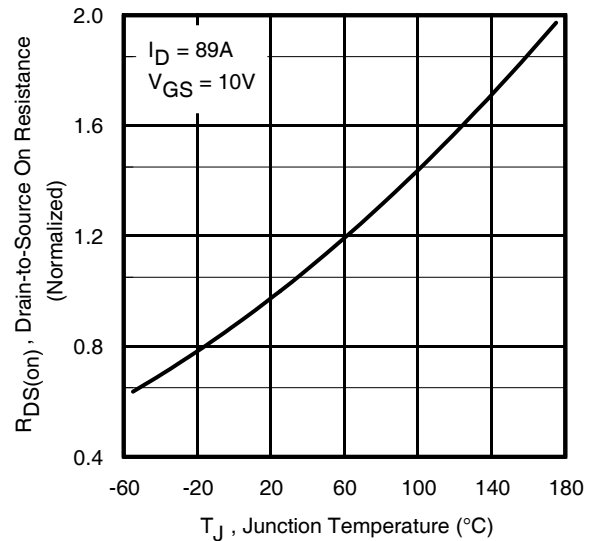
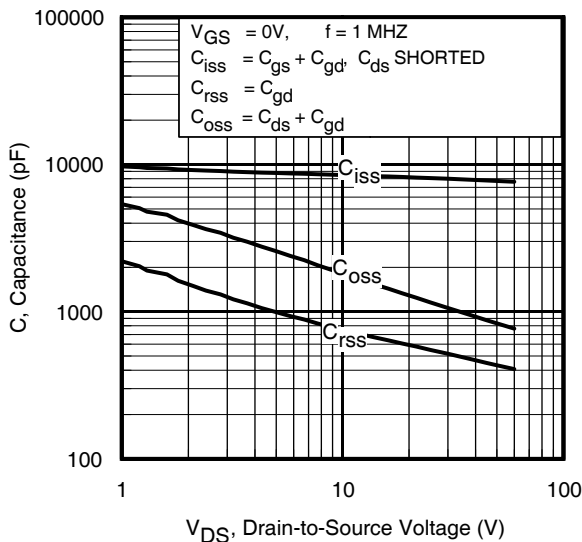
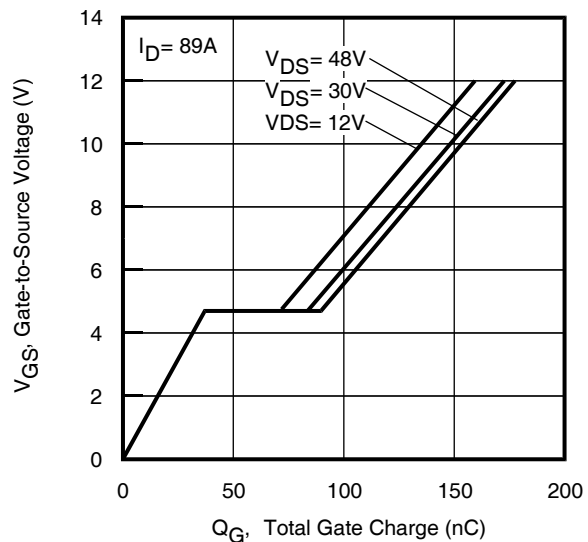
Fig 4. Typical Output Characteristics

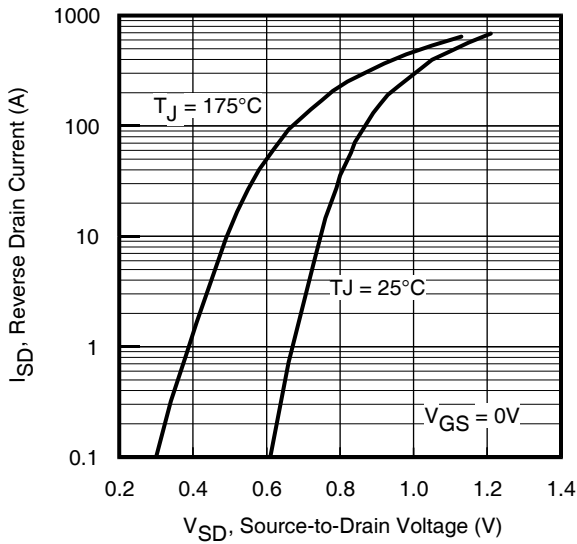
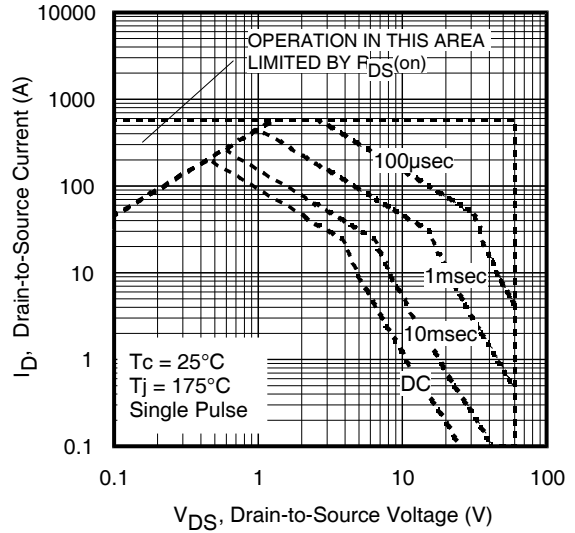
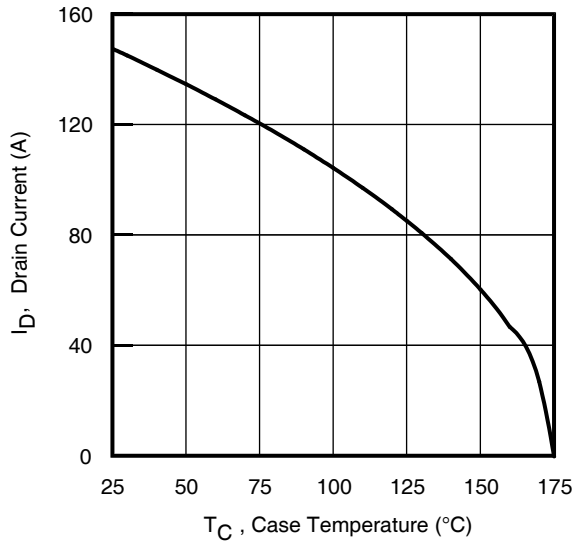
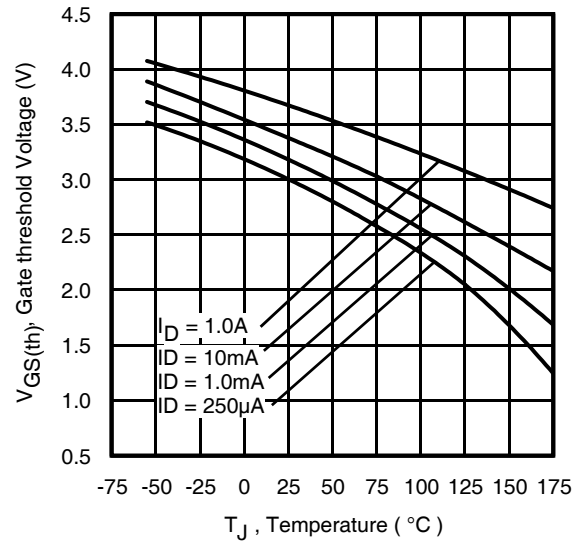
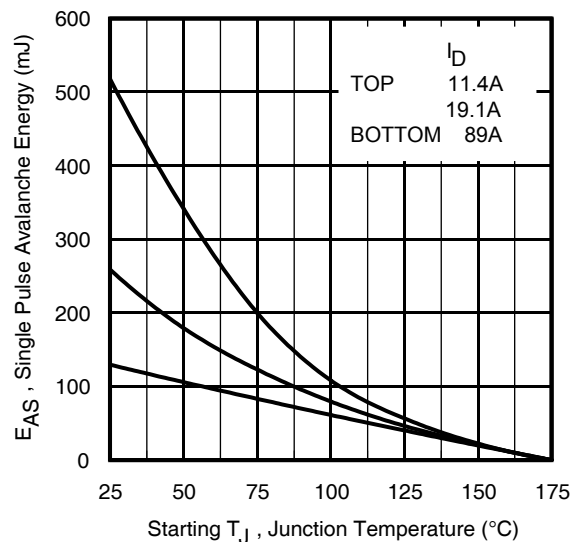
Fig 5. Typical Output Characteristics

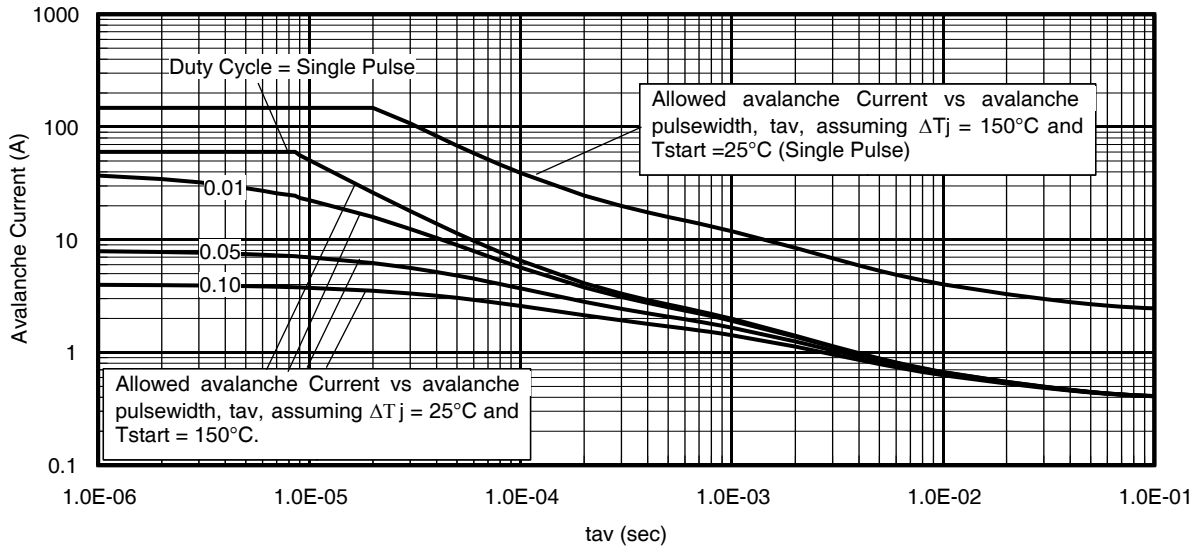
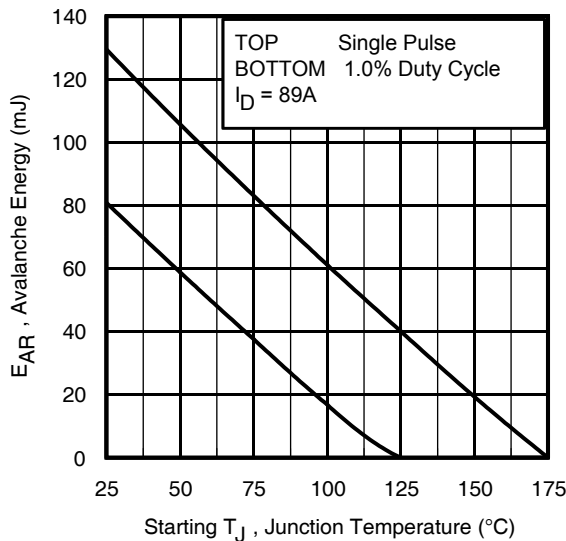
Fig 6. Typical Transfer Characteristics

Fig 7. Normalized On-Resistance vs. Temperature

Fig 8. Typical Capacitance vs. Drain-to-Source Voltage

Fig 9. Typical Gate Charge vs. Gate-to-Source Voltage

Fig 10. Typical Source-Drain Diode Forward Voltage

Fig 11. Maximum Safe Operating Area

Fig 12. Maximum Drain Current vs. Case Temperature

Fig 13. Typical Threshold Voltage vs. Junction Temperature

Fig 14. Maximum Avalanche Energy vs. Drain Current

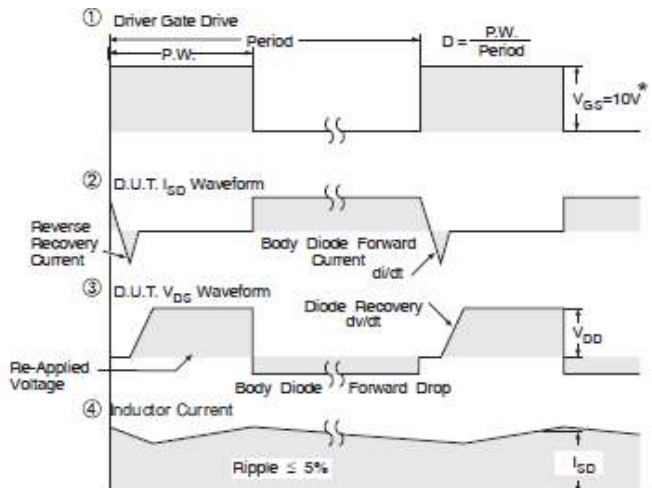
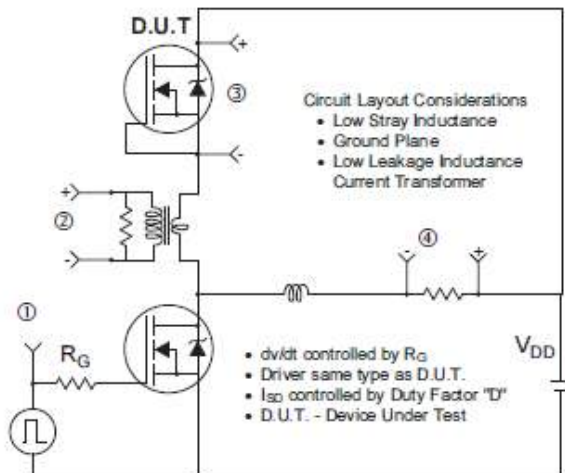

Fig 15. Typical Avalanche Current vs. Pulse width

Fig 16. Maximum Avalanche Energy vs. Temperature
**Notes on Repetitive Avalanche Curves , Figures 15, 16:
(For further info, see AN-1005)**

1. Avalanche failures assumption:
Purely a thermal phenomenon and failure occurs at a temperature far in excess of T_{jmax} . This is validated for every part type.
2. Safe operation in Avalanche is allowed as long as T_{jmax} is not exceeded.
3. Equation below based on circuit and waveforms shown in Figures 19a, 19b.
4. $P_{D(ave)}$ = Average power dissipation per single avalanche pulse.
5. BV = Rated breakdown voltage (1.3 factor accounts for voltage increase during avalanche).
6. I_{av} = Allowable avalanche current.
7. ΔT = Allowable rise in junction temperature, not to exceed T_{jmax} (assumed as 25°C in Figure 15, 16).
 t_{av} = Average time in avalanche.
 D = Duty cycle in avalanche = $t_{av} \cdot f$
 $Z_{thJC}(D, t_{av})$ = Transient thermal resistance, see Figures 3)

$$P_{D(ave)} = \frac{1}{2} (1.3 \cdot BV \cdot I_{av}) = \frac{\Delta T}{Z_{thJC}}$$

$$I_{av} = \frac{2\Delta T}{[1.3 \cdot BV \cdot Z_{th}]}$$

$$E_{AS(AR)} = P_{D(ave)} \cdot t_{av}$$



* $V_{GS} = 5V$ for Logic Level Devices

Fig 17. Peak Diode Recovery dv/dt Test Circuit for N-Channel HEXFET® Power MOSFETs

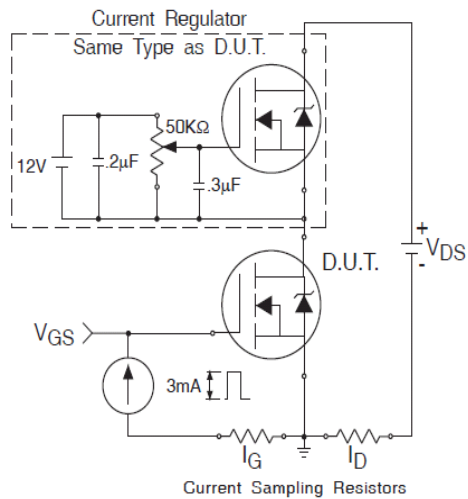
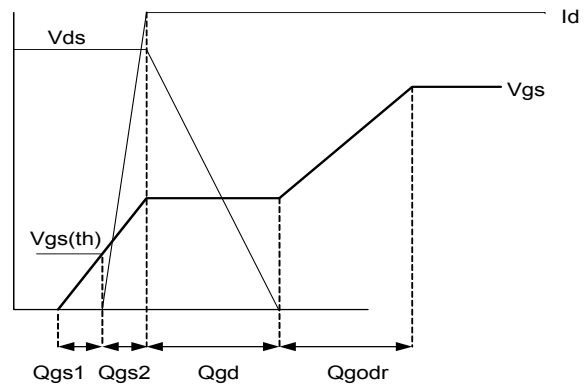
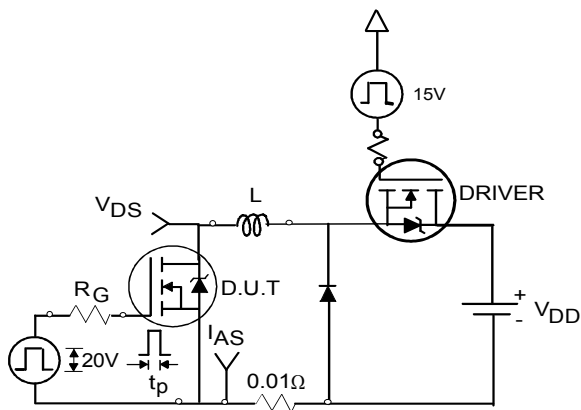
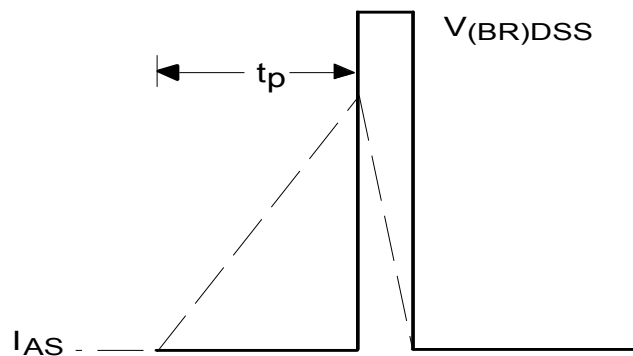
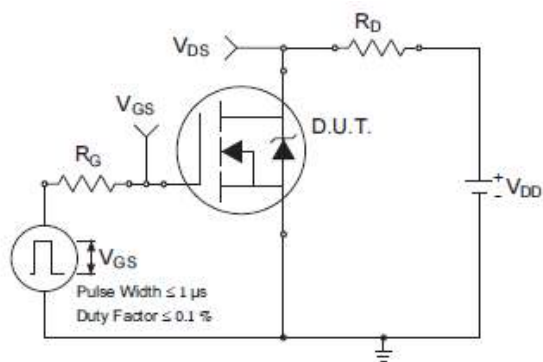
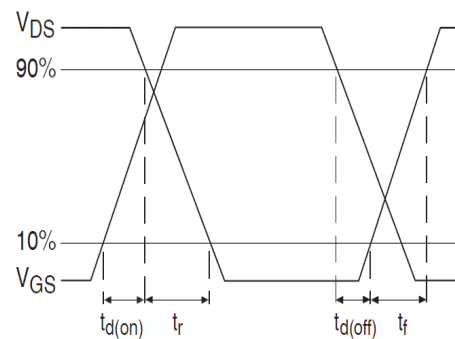
Fig 18a. Gate Charge Test Circuit

Fig 18b. Gate Charge Waveform

Fig 19a. Unclamped Inductive Test Circuit

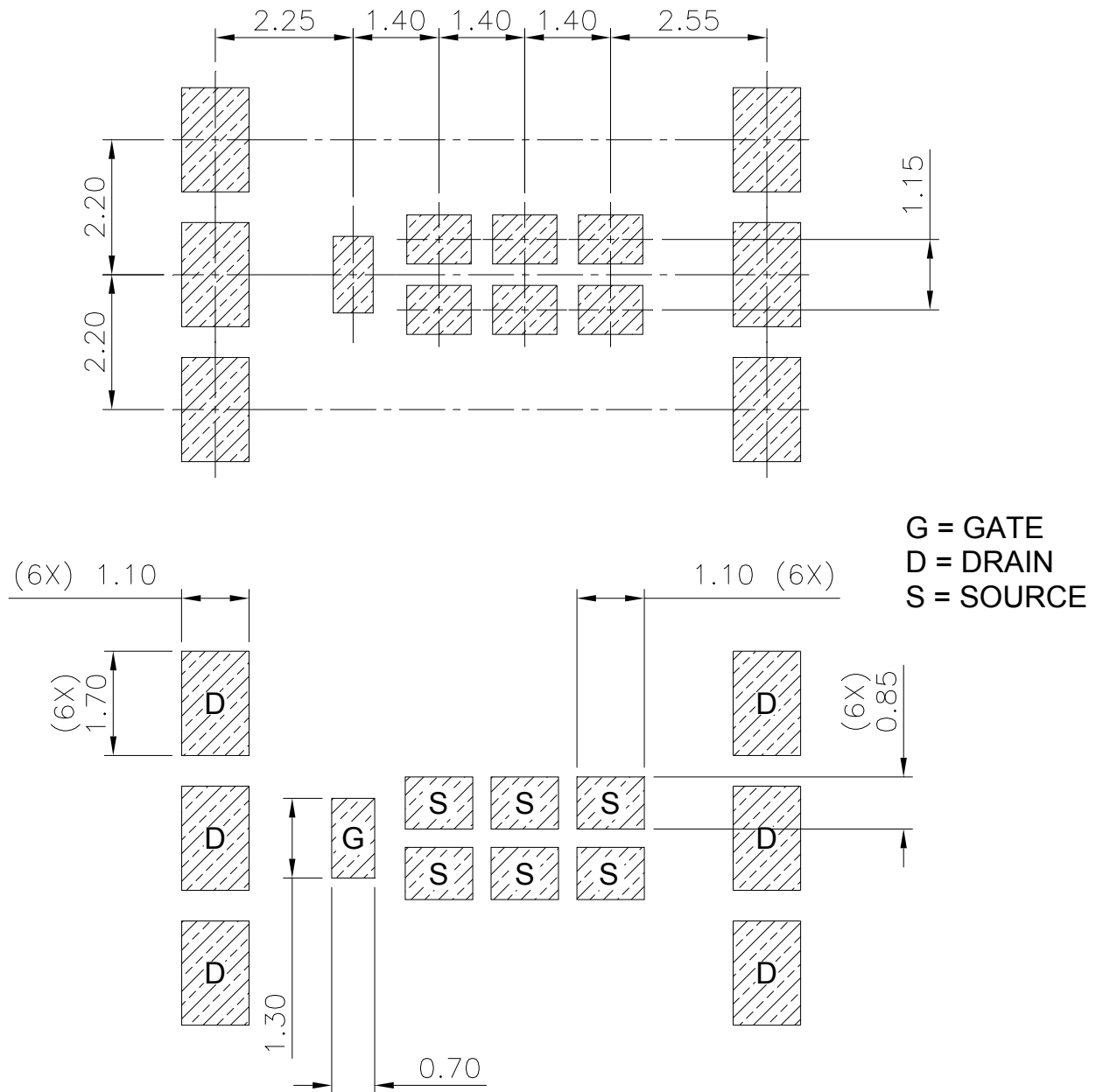
Fig 19b. Unclamped Inductive Waveforms

Fig 20a. Switching Time Test Circuit

Fig 20b. Switching Time Waveforms

DirectFET™ Board Footprint, L6 Outline (Large Size Can, 6-Source Pads).

Please see DirectFET application note [AN-1035](#) for all details regarding the assembly of DirectFET. This includes all recommendations for stencil and substrate designs.



Note: For the most current drawing please refer to IR website at <http://www.irf.com/package/>

**DirectFET® Outline Dimension, L6 Outline
(Large Size Can, 6-Source Pads).**

Please see DirectFET application note [AN-1035](#) for all details regarding the assembly of DirectFET. This includes all recommendations for stencil and substrate designs.

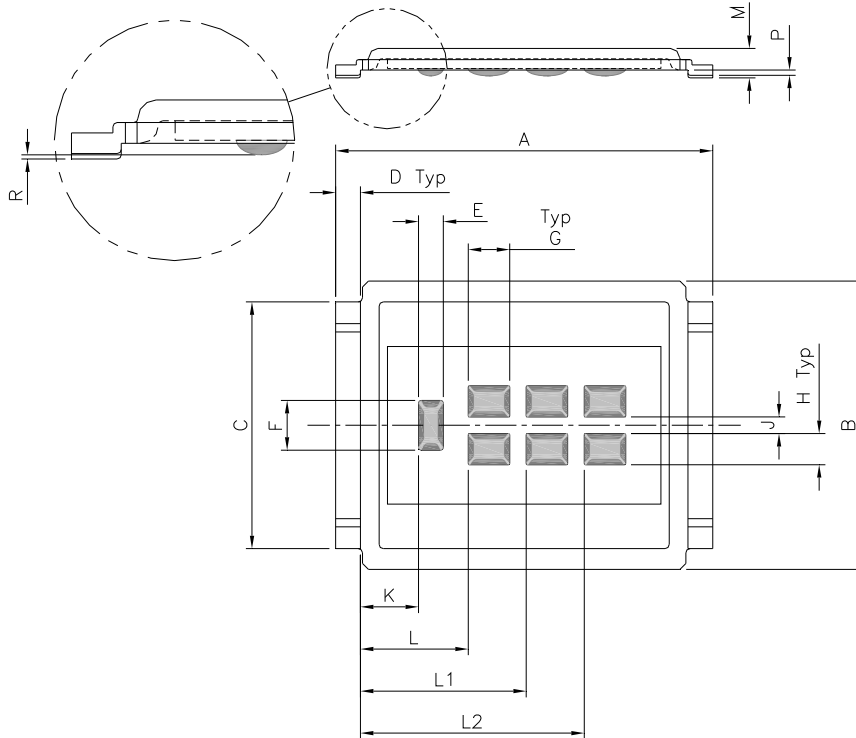

| CODE | METRIC | | IMPERIAL | |
|------|--------|------|----------|-------|
| | MIN | MAX | MIN | MAX |
| A | 9.05 | 9.15 | 0.356 | 0.360 |
| B | 6.85 | 7.10 | 0.270 | 0.280 |
| C | 5.90 | 6.00 | 0.232 | 0.236 |
| D | 0.55 | 0.65 | 0.022 | 0.026 |
| E | 0.58 | 0.62 | 0.023 | 0.024 |
| F | 1.18 | 1.22 | 0.046 | 0.048 |
| G | 0.98 | 1.02 | 0.039 | 0.040 |
| H | 0.73 | 0.77 | 0.029 | 0.030 |
| J | 0.38 | 0.42 | 0.015 | 0.017 |
| K | 1.35 | 1.45 | 0.053 | 0.057 |
| L | 2.55 | 2.65 | 0.100 | 0.104 |
| L1 | 3.95 | 4.05 | 0.155 | 0.159 |
| L2 | 5.35 | 5.45 | 0.210 | 0.214 |
| M | 0.68 | 0.74 | 0.027 | 0.029 |
| P | 0.09 | 0.17 | 0.003 | 0.007 |
| R | 0.02 | 0.08 | 0.001 | 0.003 |

Dimensions are shown in millimeters (inches)

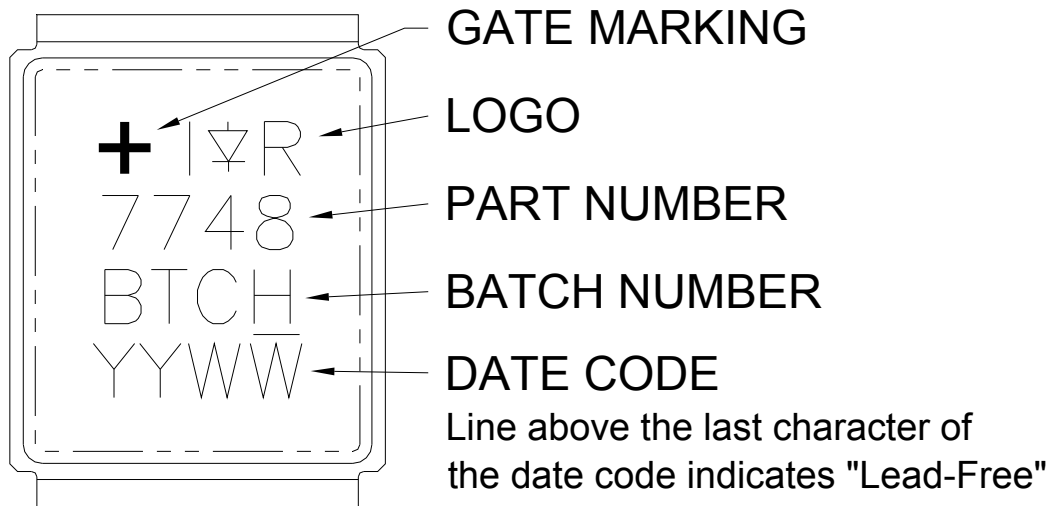
DirectFET® Part Marking

Note: For the most current drawing please refer to IR website at <http://www.irf.com/package/>

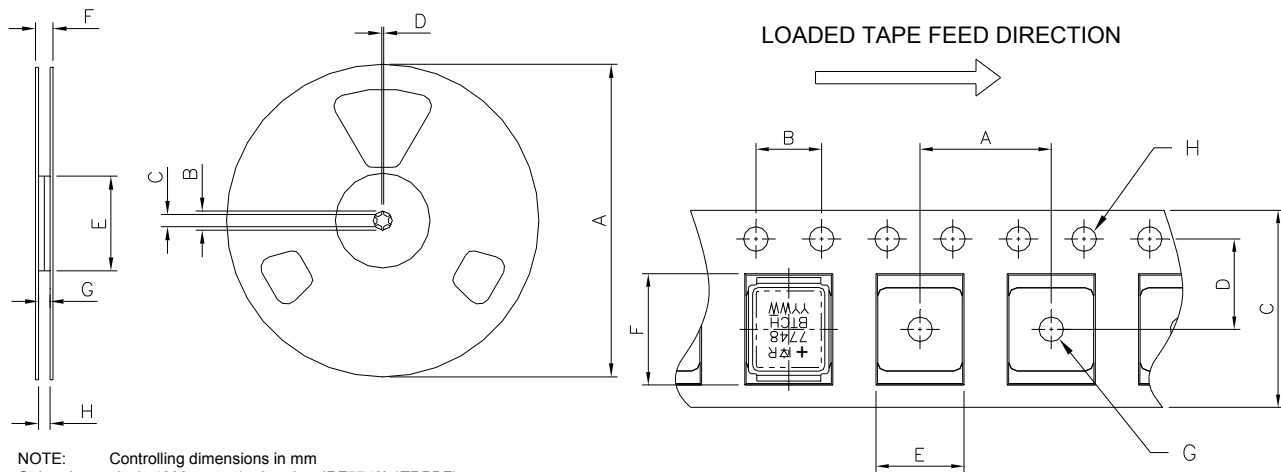
DirectFET® Tape & Reel Dimension (Showing component orientation).

NOTE: Controlling dimensions in mm
Std reel quantity is 4000 parts. (ordered as IRF7748L1TRPBF).

| REEL DIMENSIONS | | | | |
|----------------------------|--------|--------|----------|-------|
| STANDARD OPTION (QTY 4000) | | | | |
| CODE | METRIC | | IMPERIAL | |
| | MIN | MAX | MIN | MAX |
| A | 330.00 | N.C | 12.992 | N.C |
| B | 20.20 | N.C | 0.795 | N.C |
| C | 12.80 | 13.20 | 0.504 | 0.520 |
| D | 1.50 | N.C | 0.059 | N.C |
| E | 99.00 | 100.00 | 3.900 | 3.940 |
| F | N.C | 22.40 | N.C | 0.880 |
| G | 16.40 | 18.40 | 0.650 | 0.720 |
| H | 15.90 | 19.40 | 0.630 | 0.760 |

NOTE: CONTROLLING DIMENSIONS IN MM

| CODE | DIMENSIONS | | | |
|------|------------|-------|----------|-------|
| | METRIC | | IMPERIAL | |
| | MIN | MAX | MIN | MAX |
| A | 11.90 | 12.10 | 4.69 | 0.476 |
| B | 3.90 | 4.10 | 0.154 | 0.161 |
| C | 15.90 | 16.30 | 0.623 | 0.642 |
| D | 7.40 | 7.60 | 0.291 | 0.299 |
| E | 7.20 | 7.40 | 0.283 | 0.291 |
| F | 9.90 | 10.10 | 0.390 | 0.398 |
| G | 1.50 | N.C | 0.059 | N.C |
| H | 1.50 | 1.60 | 0.059 | 0.063 |

Note: For the most current drawing please refer to IR website at <http://www.irf.com/package/>

Qualification Information†

| | | |
|-----------------------------------|----------------|-----------------------------------|
| Qualification Level | Industrial†† * | |
| Moisture Sensitivity Level | DirectFET | MSL1 (per JEDEC J-STD-020D†††) |
| RoHS Compliant | Yes | |

† Qualification standards can be found at International Rectifier's web site

<http://www.irf.com/product-info/reliability>

†† Higher qualification ratings may be available should the user have such requirements.

Please contact your International Rectifier sales representative for further information:

<http://www.irf.com/whoto-call/salesrep/>

††† Applicable version of JEDEC standard at the time of product release.

* Industrial qualification standards except autoclave test conditions.

Revision History

| Date | Comments |
|---------|--|
| 2/13/13 | TR1 option removed and Tape & Reel Info updated accordingly. Hyperlinks added throw-out the document |