

GENERAL DESCRIPTION

The 87973 is a LVCMOS/LVTTL clock generator. The 87973 has three selectable inputs and provides fourteen LVCMOS/LVTTL outputs.

The 87973 is a highly flexible device. The three selectable inputs (1 differential and 2 single ended inputs) are often used in systems requiring redundant clock sources. Up to three different output frequencies can be generated among the three output banks.

The three output banks and feedback output each have their own output dividers which allows the device to generate a multitude of different bank frequency ratios and output-to-input frequency ratios. In addition, 2 outputs in Bank C (QC2, QC3) can be selected to be inverting or non-inverting. The output frequency range is 8.33MHz to 125MHz. The input frequency range is 5MHz to 120MHz.

The 87973 also has a QSYNC output which can be used for system synchronization purposes. It monitors Bank A and Bank C outputs and goes low one period prior to coincident rising edges of Bank A and Bank C clocks. QSYNC then goes high again when the coincident rising edges of Bank A and Bank C occur. This feature is used primarily in applications where Bank A and Bank C are running at different frequencies, and is particularly useful when they are running at non-integer multiples of one another.

Example Applications:

1. *System Clock generator:* Use a 16.66MHz reference clock to generate eight 33.33MHz copies for PCI and four 100MHz copies for the CPU or PCI-X.
2. *Line Card Multiplier:* Multiply differential 62.5MHz from a back plane to single-ended 125MHz for the line Card ASICs and Gigabit Ethernet Serdes.
3. *Zero Delay buffer for Synchronous memory:* Fan out up to twelve 100MHz copies from a memory controller reference clock to the memory chips on a memory module with zero delay.

FEATURES

- Fully integrated PLL
- Fourteen LVCMOS/LVTTL outputs; twelve clock outputs, one feedback, one sync
- Selectable LVCMOS/LVTTL or differential CLK, nCLK inputs
- CLK0, CLK1 can accept the following input levels: LVCMOS or LVTTL
- CLK, nCLK pair can accept the following differential input levels: LVPECL, LVDS, LVHSTL, SSTL, HCSL
- Output frequency range: 8.33MHz to 125MHz
- VCO range: 200MHz to 480MHz
- Output skew: 550ps (maximum)
- Cycle-to-cycle jitter: ± 100 ps (typical)
- Full 3.3V supply voltage
- -40°C to 85°C ambient operating temperature
- Available in lead-free RoHS compliant package
- Compatible with PowerPC™ and Pentium™ Microprocessors

PIN ASSIGNMENT

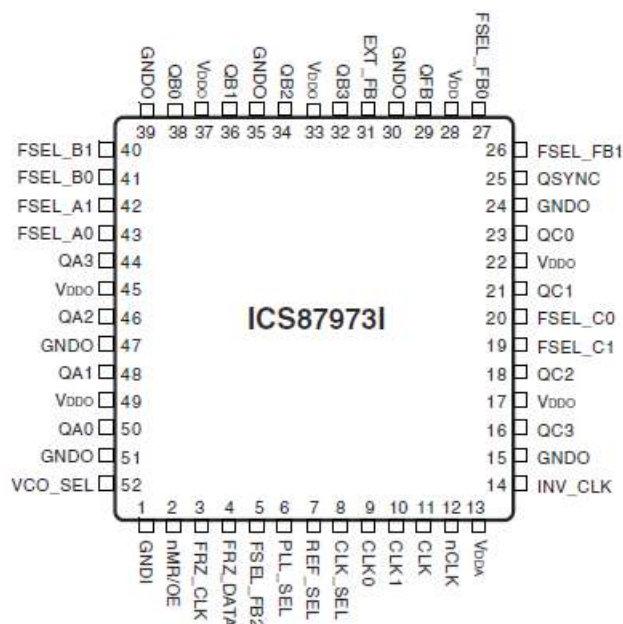

BLOCK DIAGRAM

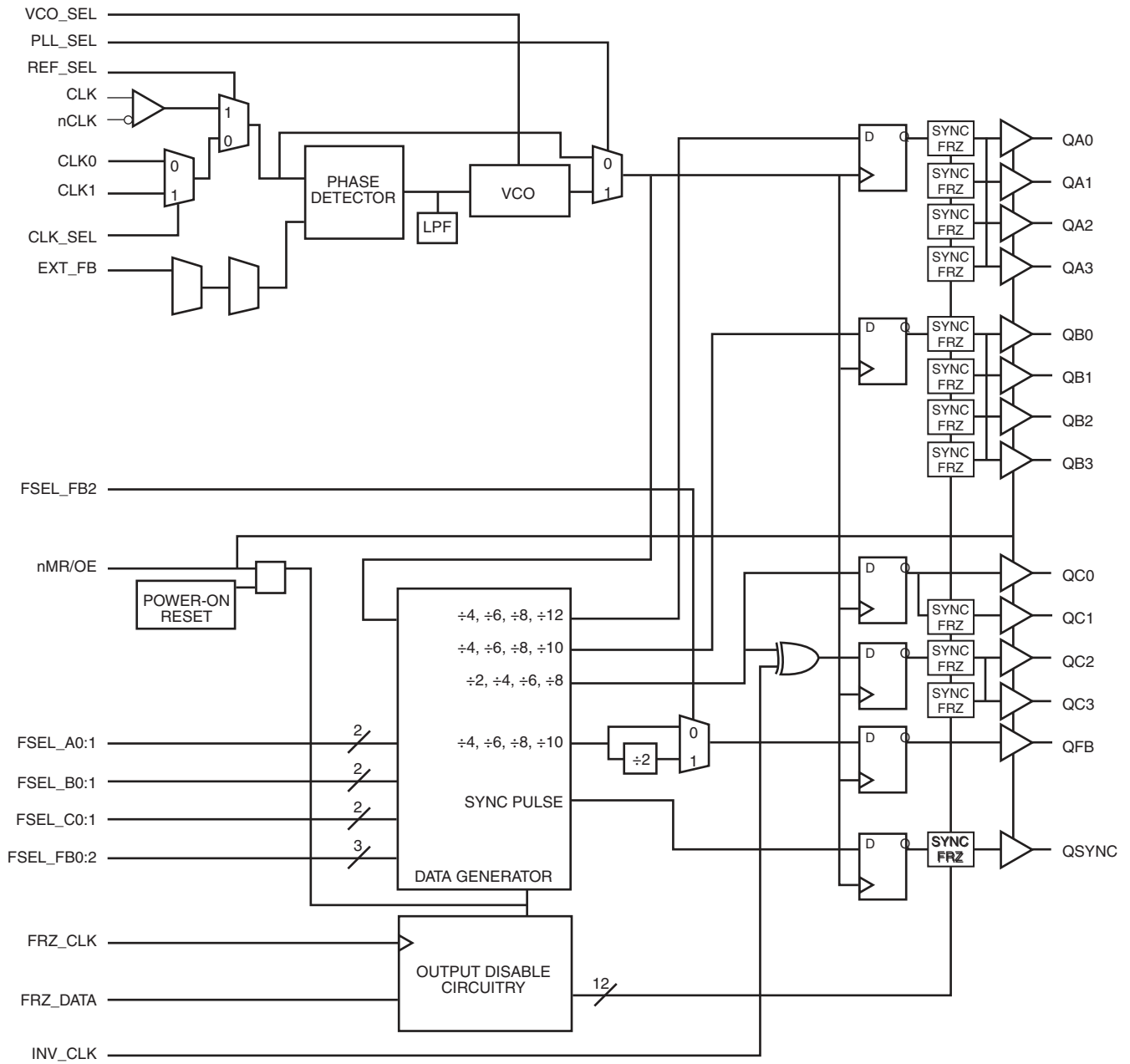

SIMPLIFIED BLOCK DIAGRAM

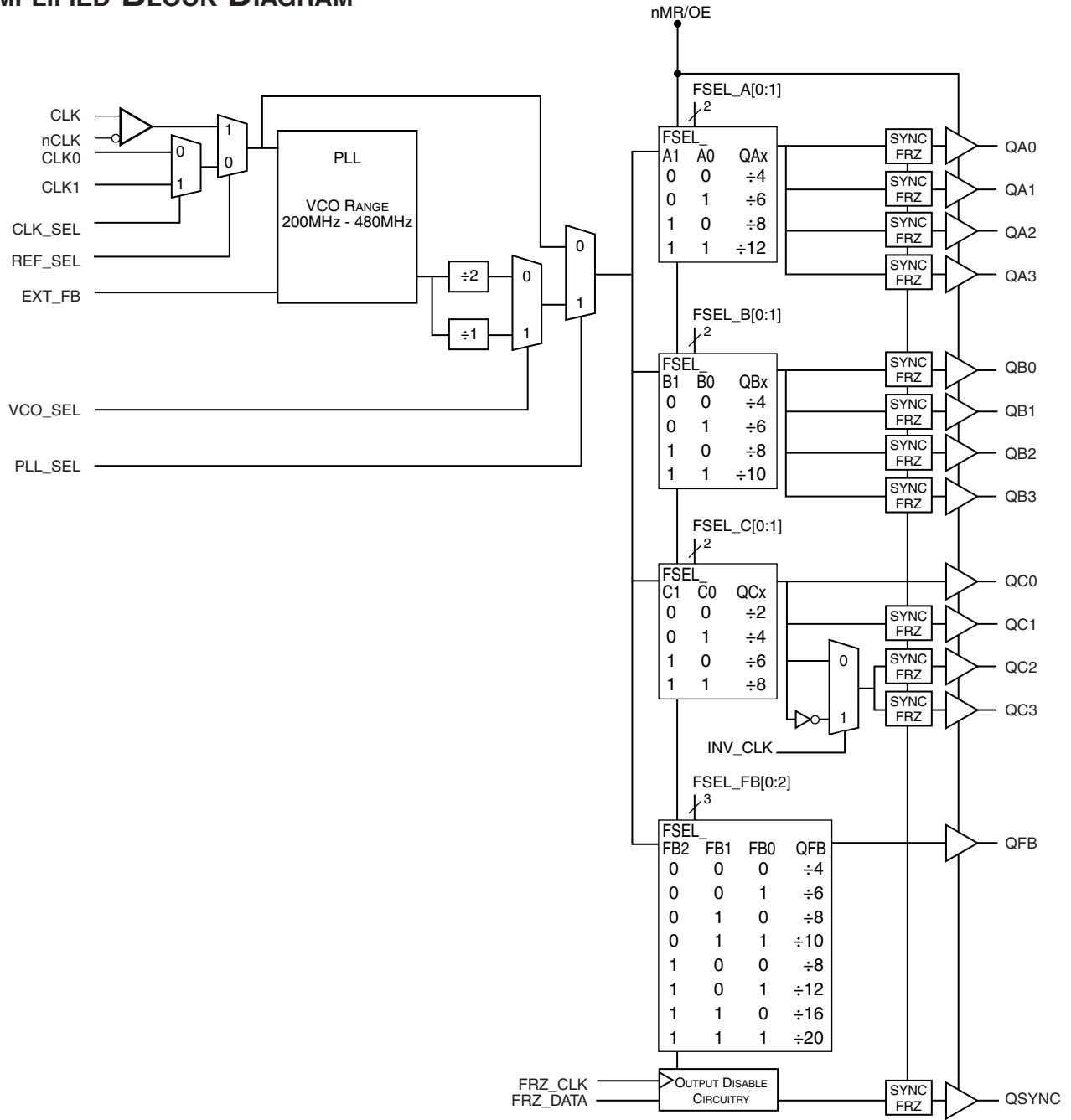

TABLE 1. PIN DESCRIPTIONS

Number	Name	Type		Description
1	GNDI	Power		Power supply ground.
2	nMR/OE	Input	Pullup	Master reset and output enable. When HIGH, enables the outputs. When LOW, resets the outputs to tristate and resets output divide circuitry. Enables and disables all outputs. LVCMOS / LVTTTL interface levels.
3	FRZ_CLK	Input	Pullup	Clock input for freeze circuitry. LVCMOS / LVTTTL interface levels.
4	FRZ_DATA	Input	Pullup	Configuration data input for freeze circuitry. LVCMOS / LVTTTL interface levels.
5, 26, 27	FSEL_FB2, FSEL_FB1, FSEL_FB0	Input	Pullup	Select pins control Feedback Divide value. LVCMOS / LVTTTL interface levels.
6	PLL_SEL	Input	Pullup	Selects between the PLL and reference clocks as the input to the output dividers. When HIGH, selects PLL. When LOW, bypasses the PLL. LVCMOS / LVTTTL interface levels.
7	REF_SEL	Input	Pullup	Selects between CLK0 or CLK1 and CLK, nCLK inputs. When HIGH, selects CLK, nCLK. When LOW, selects CLK0 or CLK1. LVCMOS / LVTTTL interface levels.
8	CLK_SEL	Input	Pullup	Clock select input. Selects between CLK0 and CLK1 as phase detector reference. When LOW, selects CLK0. When HIGH, selects CLK1. LVCMOS / LVTTTL interface levels.
9, 10	CLK0,CLK1	Input	Pullup	Reference clock inputs. LVCMOS / LVTTTL interface levels.
11	CLK	Input	Pullup	Non-inverting differential clock input.
12	nCLK	Input	Pullup/ Pulldown	Inverting differential clock input. $V_{DD}/2$ default when left floating.
13	V_{DDA}	Power		Analog supply pin.
14	INV_CLK	Input	Pullup	Inverted clock select for QC2 and QC3 outputs. LVCMOS / LVTTTL interface levels.
15, 24, 30, 35, 39, 47, 51	GND0	Power		Power supply ground.
16, 18, 21, 23	QC3, QC2, QC1, QC0	Output		Bank C clock outputs. 7Ω typical output impedance. LVCMOS / LVTTTL interface levels.
17, 22, 33, 37, 45, 49	V_{DDO}	Power		Output supply pins.
19, 20	FSEL_C1, FSEL_C0	Input	Pullup	Select pins for Bank C outputs. LVCMOS / LVTTTL interface levels.
25	QSYNC	Output		Synchronization output for Bank A and Bank C. Refer to Figure 1, Timing Diagrams. LVCMOS / LVTTTL interface levels.
28	V_{DD}	Power		Core supply pins.
29	QFB	Output		Feedback clock output. LVCMOS / LVTTTL interface levels.
31	EXT_FB	Input	Pullup	Extended feedback. LVCMOS / LVTTTL interface levels.
32, 34, 36, 38	QB3, QB2, QB1, QB0	Output		Bank B clock outputs. 7Ω typical output impedance. LVCMOS / LVTTTL interface levels.
40, 41	FSEL_B1, FSEL_B0	Input	Pullup	Select pins for Bank B outputs. LVCMOS / LVTTTL interface levels.
42, 43	FSEL_A1, FSEL_A0	Input	Pullup	Select pins for Bank A outputs. LVCMOS / LVTTTL interface levels.
44, 46, 48, 50	QA3, QA2, QA1, QA0	Output		Bank A clock outputs. 7Ω typical output impedance. LVCMOS / LVTTTL interface levels.
52	VCO_SEL	Input	Pullup	Selects VCO. When HIGH, selects $VCO \div 1$. When LOW, selects $VCO \div 2$. LVCMOS / LVTTTL interface levels.

NOTE: Pullup and Pulldown refer to internal input resistors. See table 2, Pin Characteristics, for typical values.

TABLE 2. PIN CHARACTERISTICS

Symbol	Parameter	Test Conditions	Minimum	Typical	Maximum	Units
C_{IN}	Input Capacitance			4		pF
$R_{PULLUP}/R_{PULLDOWN}$	Input Pullup/Pulldown Resistor			51		k Ω
C_{PD}	Power Dissipation Capacitance (per output)	$V_{DD}, V_{DDA}, V_{DDO} = 3.465V$			18	pF
R_{OUT}	Output Impedance		5	7	12	Ω

TABLE 3A. OUTPUT BANK CONFIGURATION SELECT FUNCTION TABLE

Inputs		Outputs	Inputs		Outputs	Inputs		Outputs
FSEL_A1	FSEL_A0	QA	FSEL_B1	FSEL_B0	QB	FSEL_C1	FSEL_C0	QC
0	0	$\div 4$	0	0	$\div 4$	0	0	$\div 2$
0	1	$\div 6$	0	1	$\div 6$	0	1	$\div 4$
1	0	$\div 8$	1	0	$\div 8$	1	0	$\div 6$
1	1	$\div 12$	1	1	$\div 10$	1	1	$\div 8$

TABLE 3B. FEEDBACK CONFIGURATION SELECT FUNCTION TABLE

Inputs			Outputs
FSEL_FB2	FSEL_FB1	FSEL_FB0	QFB
0	0	0	$\div 4$
0	0	1	$\div 6$
0	1	0	$\div 8$
0	1	1	$\div 10$
1	0	0	$\div 8$
1	0	1	$\div 12$
1	1	0	$\div 16$
1	1	1	$\div 20$

TABLE 3C. CONTROL INPUT SELECT FUNCTION TABLE

Control Pin	Logic 0	Logic 1
VCO_SEL	VCO/2	VCO
REF_SEL	CLK0 or CLK1	CLK, nCLK
CLK_SEL	CLK0	CLK1
PLL_SEL	BYPASS PLL	Enable PLL
nMR/OE	Master Reset/Output Hi Z	Enable Outputs
INV_CLK	Non-Inverted QC2, QC3	Inverted QC2, QC3

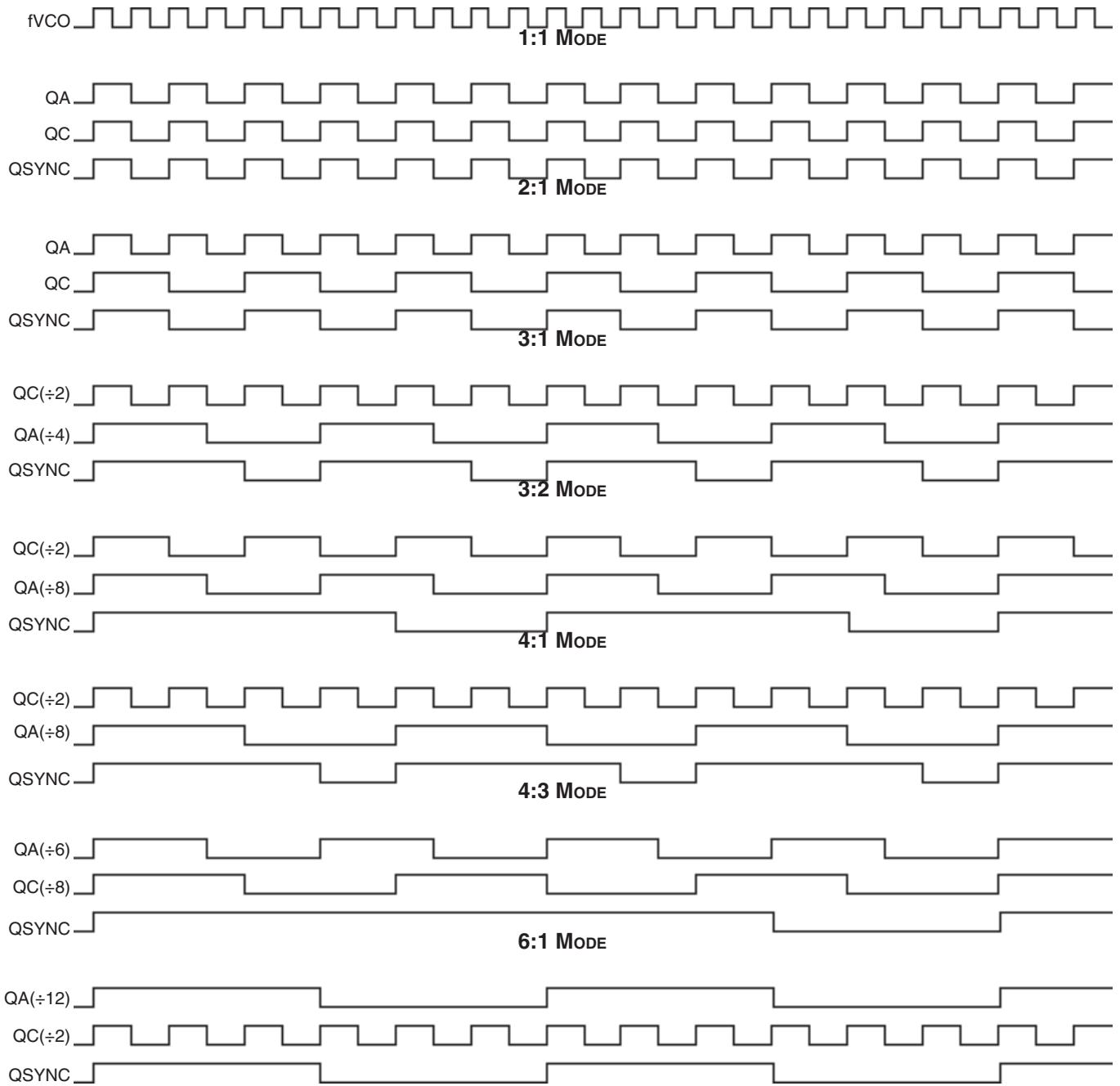

FIGURE 1. TIMING DIAGRAMS

ABSOLUTE MAXIMUM RATINGS

Supply Voltage, V_{DD}	4.6V
Inputs, V_I	-0.5V to $V_{DD} + 0.5V$
Outputs, V_O	-0.5V to $V_{DDO} + 0.5V$
Package Thermal Impedance, θ_{JA}	42.3°C/W (0 lfpm)
Storage Temperature, T_{STG}	-65°C to 150°C

NOTE: Stresses beyond those listed under Absolute Maximum Ratings may cause permanent damage to the device. These ratings are stress specifications only. Functional operation of product at these conditions or any conditions beyond those listed in the *DC Characteristics* or *AC Characteristics* is not implied. Exposure to absolute maximum rating conditions for extended periods may affect product reliability.

TABLE 4A. POWER SUPPLY DC CHARACTERISTICS, $V_{DD} = V_{DDA} = V_{DDO} = 3.3V \pm 5\%$, $T_A = -40^\circ C$ TO $85^\circ C$

Symbol	Parameter	Test Conditions	Minimum	Typical	Maximum	Units
V_{DD}	Core Supply Voltage		3.135	3.3	3.465	V
V_{DDA}	Analog Supply Voltage		2.935	3.3	3.465	V
V_{DDO}	Output Supply Voltage		3.135	3.3	3.465	V
I_{DD}	Power Supply Current	All power pins			225	mA
I_{DDA}	Analog Supply Current				20	mA

NOTE: Special thermal handling may be required in some configurations.

TABLE 4B. DC CHARACTERISTICS, $V_{DD} = V_{DDA} = V_{DDO} = 3.3V \pm 5\%$, $T_A = -40^\circ C$ TO $85^\circ C$

Symbol	Parameter	Test Conditions	Minimum	Typical	Maximum	Units
V_{IH}	Input High Voltage		2		3.6	V
V_{IL}	Input Low Voltage				0.8	V
I_{IN}	Input Current				± 120	μA
V_{OH}	Output High Voltage	$I_{OH} = -20mA$	2.4			V
V_{OL}	Output Low Voltage	$I_{OL} = 20mA$			0.5	V
V_{PP}	Peak-to-Peak Input Voltage; NOTE 1, 2	CLK, nCLK	0.3		1	V
V_{CMR}	Common Mode Input Voltage; NOTE 1, 2	CLK, nCLK	$V_{DD} - 2V$		$V_{DD} - 0.6V$	V

NOTE 1: Common mode voltage is defined as V_{IH} .

NOTE 2: For single ended applications, the maximum input voltage for CLK and nCLK is $V_{DD} + 0.3V$.

TABLE 5. INPUT FREQUENCY CHARACTERISTICS, $V_{DD} = V_{DDA} = V_{DDO} = 3.3V \pm 5\%$, $T_A = -40^\circ C$ TO $85^\circ C$

Symbol	Parameter	Test Conditions	Minimum	Typical	Maximum	Units
f_{IN}	Input Frequency	CLK0, CLK1, CLK, nCLK; NOTE 1			120	MHz
		FRZ_CLK			20	MHz

NOTE 1: Input frequency depends on the feedback divide ratio to ensure "clock * Feedback Divide" is in the VCO range of 200MHz to 480MHz.

TABLE 6. AC CHARACTERISTICS, $V_{DD} = V_{DDA} = V_{DDO} = 3.3V \pm 5\%$, $T_A = -40^\circ\text{C}$ TO 85°C

Symbol	Parameter	Test Conditions	Minimum	Typical	Maximum	Units	
fMAX	Output Frequency	± 2			125	MHz	
		± 4			120	MHz	
		± 6			80	MHz	
		± 8			60	MHz	
t(\emptyset)	Static Phase Offset; NOTE 1	CLK0	QFB ± 8 In Frequency = 50MHz	-70	130	330	ps
		CLK1		-130	70	270	ps
		CLK, nCLK		-225	-25	175	ps
t _{sk(o)}	Output Skew; NOTE 2				550	ps	
tjit(cc)	Cycle-to-Cycle Jitter; NOTE 3, 4			± 100		ps	
f _{VCO}	PLL VCO Lock Range		200		480	MHz	
t _{LOCK}	PLL Lock Time; NOTE 3				10	mS	
t _R /t _F	Output Rise/Fall Time; NOTE 3	0.8V to 2V	0.15		1.2	ns	
t _{PW}	Output Pulse Width		$\frac{t_{PERIOD}}{2} - \frac{750}{750}$	$\frac{t_{PERIOD}}{2} \pm \frac{500}{500}$	$\frac{t_{PERIOD}}{2} + \frac{750}{750}$	ps	
t _{PZL} , t _{PZH}	Output Enable Time; NOTE 3		2		10	ns	
t _{PLZ} , t _{PHZ}	Output Disable Time; NOTE 3		2		8	ns	

NOTE 1: Defined as the time difference between the input reference clock and the average feedback input signal when the PLL is locked and the input reference frequency is stable.

NOTE 2: Defined as skew between outputs at the same supply voltage and with equal load conditions.

Measured at $V_{DDO}/2$.

NOTE 3: These parameters are guaranteed by characterization. Not tested in production.

NOTE 4: This parameter is defined in accordance with JEDEC Standard 65.

PARAMETER MEASUREMENT INFORMATION

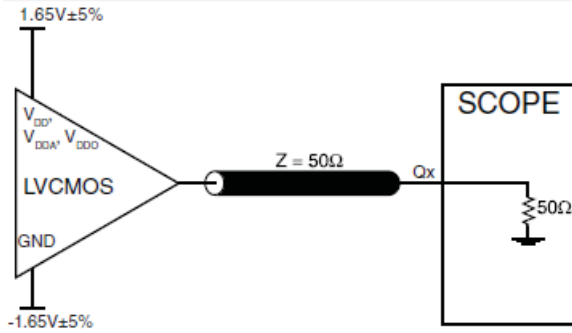

3.3V OUTPUT LOAD AC TEST CIRCUIT

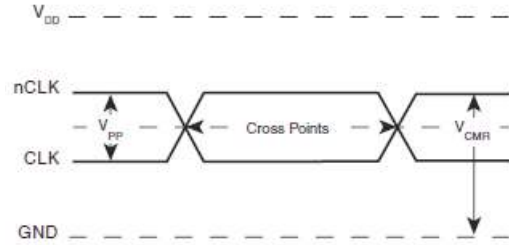

DIFFERENTIAL INPUT LEVEL

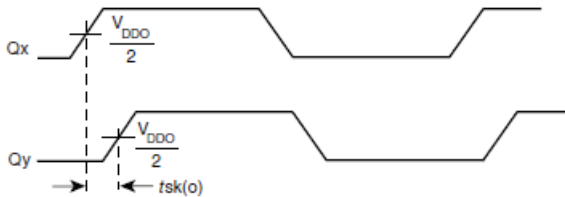

OUTPUT SKEW

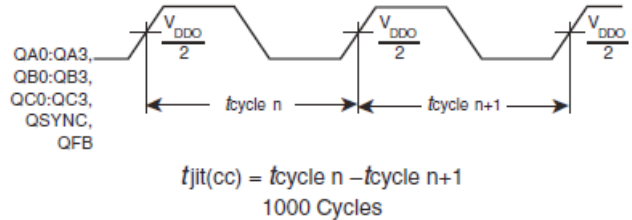

CYCLE-TO-CYCLE JITTER

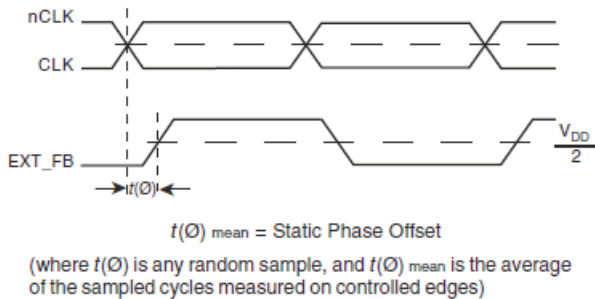

STATIC PHASE OFFSET (DIFFERENTIAL)

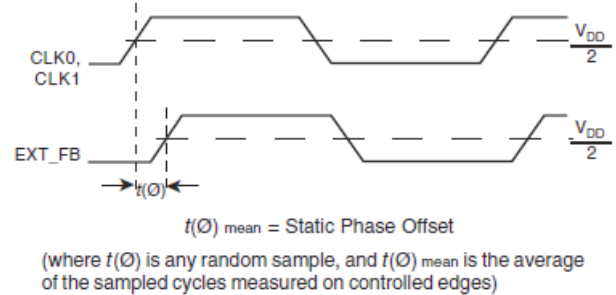

STATIC PHASE OFFSET (LVCMOS)

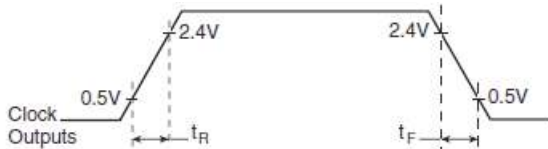

OUTPUT RISE/FALL TIME

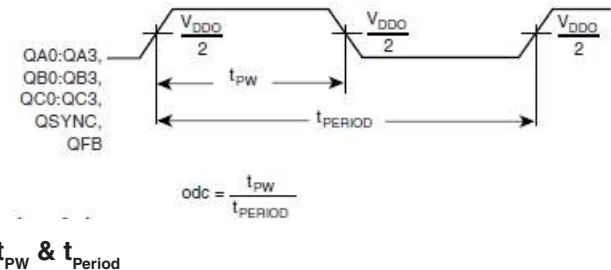

APPLICATION INFORMATION

USING THE OUTPUT FREEZE CIRCUITRY

OVERVIEW

To enable low power states within a system, each output of 87973 (Except QC0 and QFB) can be individually frozen (stopped in the logic “0” state) using a simple serial interface to a 12 bit shift register. A serial interface was chosen to eliminate the need for each output to have its own Output Enable pin, which would dramatically increase pin count and package cost. Common sources in a system that can be used to drive the 87973 serial interface are FPGA’s and ASICs.

PROTOCOL

The Serial interface consists of two pins, FRZ_Data (Freeze Data) and FRZ_CLK (Freeze Clock). Each of the outputs which can be frozen has its own freeze enable bit in the 12 bit shift register. The sequence is started by supplying a logic “0” start bit followed by 12NRZ freeze enable bits. The period of each FRZ_DATA bit equals the period of the FRZ_CLK signal. The FRZ_DATA serial transmission should be timed so the 87973 can sample each FRZ_DATA bit with the rising edge of the FRZ_CLK

signal. To place an output in the freeze state, a logic “0” must be written to the respective freeze enable bit in the shift register. To unfreeze an output, a logic “1” must be written to the respective freeze enable bit. Outputs will not become enabled/disabled until all 12 data bits are shifted into the shift register. When all 12 data bits are shifted in the register, the next rising edge of FRZ_CLK will enable or disable the outputs. If the bit that is following the 12th bit in the register is a logic “0”, it is used for the start bit of the next cycle; otherwise, the device will wait and won’t start the next cycle until it sees a logic “0” bit. Freezing and unfreezing of the output clock is synchronous (see the timing diagram below). When going into a frozen state, the output clock will go LOW at the time it would normally go LOW, and the freeze logic will keep the output low until unfrozen. Likewise, when coming out of the frozen state, the output will go HIGH only when it would normally go HIGH. This logic, therefore, prevents runt pulses when going into and out of the frozen state.

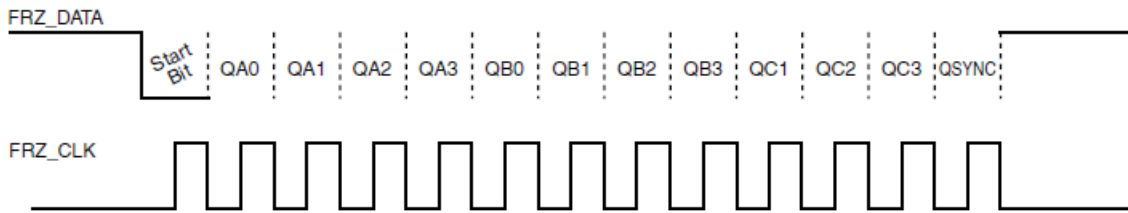

FIGURE 2A. FREEZE DATA INPUT PROTOCOL

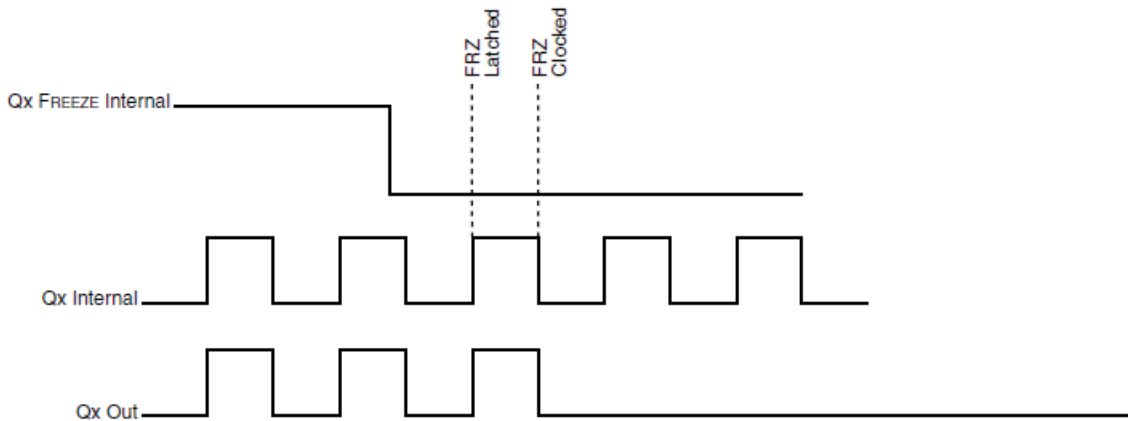

FIGURE 2B. OUTPUT DISABLE TIMING

POWER SUPPLY FILTERING TECHNIQUES

As in any high speed analog circuitry, the power supply pins are vulnerable to random noise. The 87973 provides separate power supplies to isolate any high switching noise from the outputs to the internal PLL. V_{DD} , V_{DDA} , and V_{DDO} should be individually connected to the power supply plane through vias, and bypass capacitors should be used for each pin. To achieve optimum jitter performance, power supply isolation is required. *Figure 3* illustrates how a 10Ω resistor along with a $10\mu\text{F}$ and a $.01\mu\text{F}$ bypass capacitor should be connected to each V_{DDA} pin. The 10Ω resistor can also be replaced by a ferrite bead.

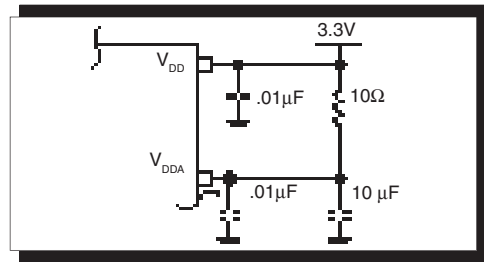

FIGURE 3. POWER SUPPLY FILTERING

WIRING THE DIFFERENTIAL INPUT TO ACCEPT SINGLE ENDED LEVELS

Figure 4 shows how the differential input can be wired to accept single ended levels. The reference voltage $V_{REF} = V_{DD}/2$ is generated by the bias resistors R1, R2 and C1. This bias circuit should be located as close as possible to the input pin. The ratio

of R1 and R2 might need to be adjusted to position the V_{REF} in the center of the input voltage swing. For example, if the input clock swing is only 2.5V and $V_{DD} = 3.3\text{V}$, V_{REF} should be 1.25V and $R2/R1 = 0.609$.

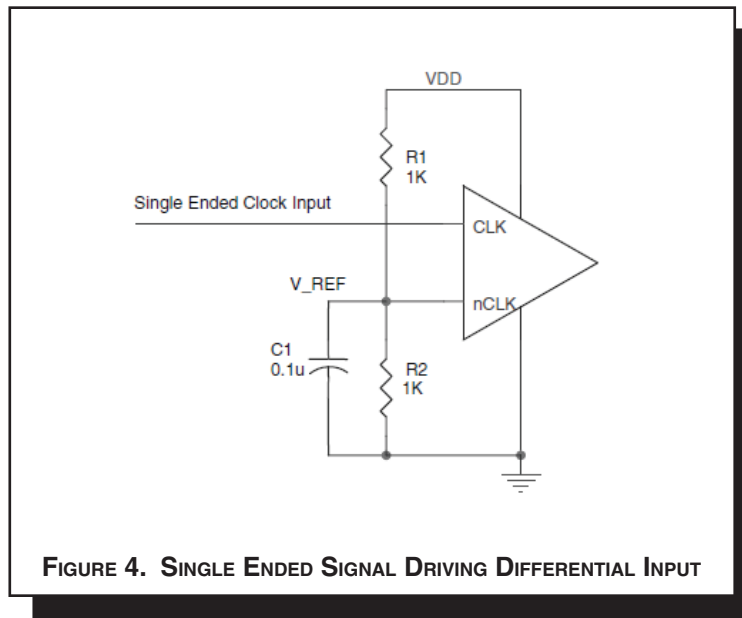

FIGURE 4. SINGLE ENDED SIGNAL DRIVING DIFFERENTIAL INPUT

DIFFERENTIAL CLOCK INPUT INTERFACE

The CLK/nCLK accepts LVDS, LVPECL, LVHSTL, SSTL, HCSL and other differential signals. Both V_{SWING} and V_{OH} must meet the V_{PP} and V_{CMR} input requirements. Figures 5A to 5D show interface examples for the CLK/nCLK input driven by the most common driver types. The input interfaces suggested here are

examples only. Please consult with the vendor of the driver component to confirm the driver termination requirements. For example in *Figure 5A*, the input termination applies for LVHSTL drivers. If you are using an LVHSTL driver from another vendor, use their termination recommendation.

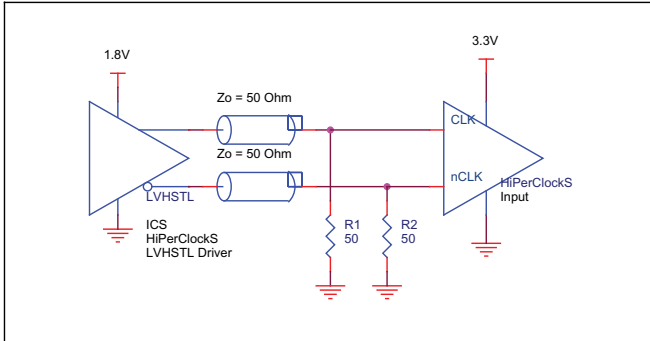

FIGURE 5A. CLK/nCLK INPUT DRIVEN BY LVHSTL DRIVER

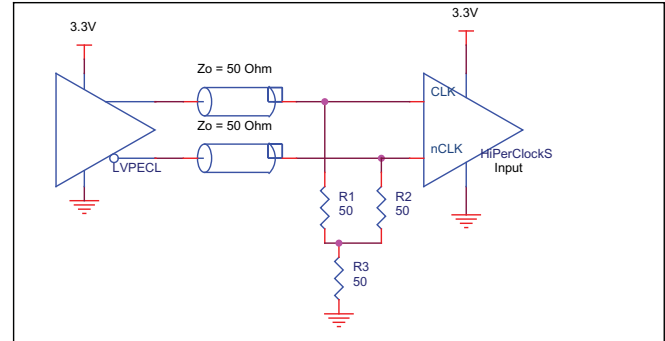

FIGURE 5B. CLK/nCLK INPUT DRIVEN BY 3.3V LVPECL DRIVER

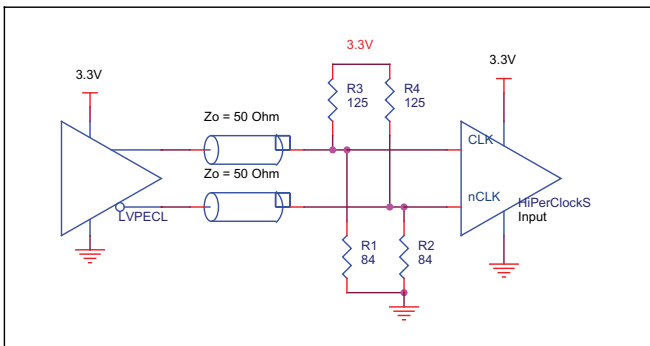

FIGURE 5C. CLK/nCLK INPUT DRIVEN BY 3.3V LVPECL DRIVER

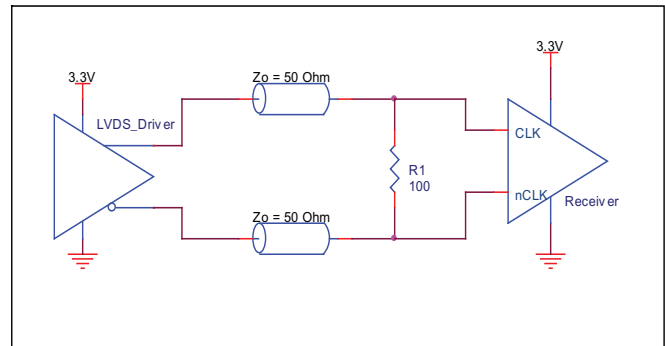

FIGURE 5D. CLK/nCLK INPUT DRIVEN BY 3.3V LVDS DRIVER

RECOMMENDATIONS FOR UNUSED INPUT AND OUTPUT PINS

INPUTS:

CLK INPUT:

For applications not requiring the use of a clock input, it can be left floating. Though not required, but for additional protection, a 1k Ω resistor can be tied from the CLK input to ground.

CLK/nCLK INPUT:

For applications not requiring the use of the differential input, both CLK and nCLK can be left floating. Though not required, but for additional protection, a 1k Ω resistor can be tied from CLK to ground.

LVC MOS CONTROL PINS:

All control pins have internal pull-ups or pull-downs; additional resistance is not required but can be added for additional protection. A 1k Ω resistor can be used.

OUTPUTS:

LVC MOS OUTPUT:

All unused LVC MOS output can be left floating. There should be no trace attached.

RELIABILITY INFORMATION

TABLE 7. θ_{JA} VS. AIR FLOW TABLE

θ_{JA} by Velocity (Linear Feet per Minute)			
	0	200	500
Single-Layer PCB, JEDEC Standard Test Boards	58.0°C/W	47.1°C/W	42.0°C/W
Multi-Layer PCB, JEDEC Standard Test Boards	42.3°C/W	36.4°C/W	34.0°C/W

NOTE: Most modern PCB designs use multi-layered boards. The data in the second row pertains to most designs.

TRANSISTOR COUNT

The transistor count for 87973 is: 8364

PACKAGE OUTLINE - Y SUFFIX FOR 52 LEAD LQFP

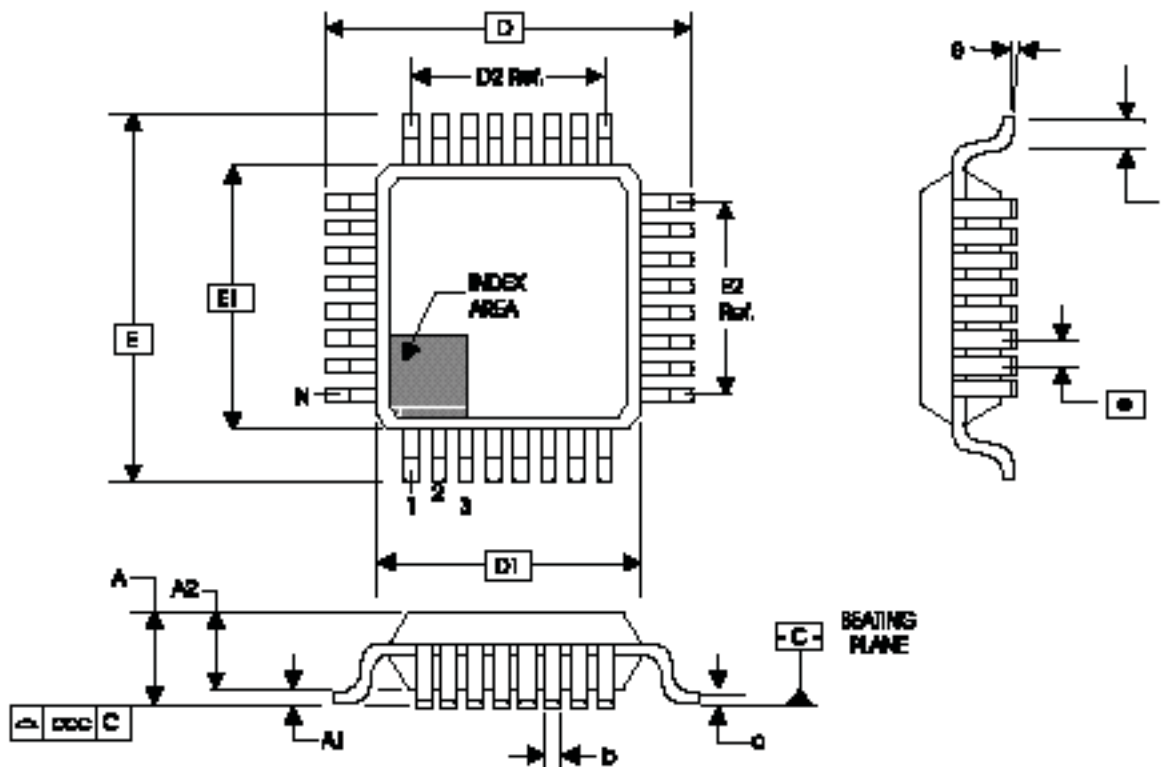

TABLE 8. PACKAGE DIMENSIONS

JEDEC VARIATION ALL DIMENSIONS IN MILLIMETERS			
SYMBOL	BCC		
	MINIMUM	NOMINAL	MAXIMUM
N	52		
A	--	--	1.60
A1	0.05	--	0.15
A2	1.35	1.40	1.45
b	0.22	0.32	0.38
c	0.09	--	0.20
D	12.00 BASIC		
D1	10.00 BASIC		
E	12.00 BASIC		
E1	10.00 BASIC		
e	0.65 BASIC		
L	0.45	--	0.75
θ	0°	--	7°
ccc	--	--	0.08

Reference Document: JEDEC Publication 95, MS-026

TABLE 9. ORDERING INFORMATION

Part/Order Number	Marking	Package	Shipping Packaging	Temperature
87973DYILF	ICS87973DYILF	52 Lead "Lead-Free" LQFP	tray	-40°C to 85°C
87973DYILFT	ICS87973DYILF	52 Lead "Lead-Free" LQFP	tape & reel	-40°C to 85°C

REVISION HISTORY SHEET				
Rev	Table	Page	Description of Change	Date
A	T1	4	Pin Description Table - added pins 20 and 21.	9/9/02
A		2	Block Diagram - added missing dividers to the Data Generator.	10/18/02
B	T4B	7	DC Characteristics table - updated V _{CMR} values from GND + 1.5V min., V _{DD} max. to V _{DD} - 2V min., V _{DD} - 0.6V max.	10/23/02
B	T1	4	Pin Description Table - corrected CLK Type to read Pullup from Pulldown.	11/18/02
	T8	12	Revised Package Drawing. Corrected Package Dimensions table to correspond with the Package Drawing.	
B		1	Added LVTTTL to title.	12/10/02
		12	Corrected Package Outline to correspond with the Package Dimensions table.	
C	T2	5	Pin Characteristics - changed the C _{PD} limit from 25pF typical to 18pF max.	3/21/03
	T4A	7	Power Supply Table - changed the I _{DD} limit from 215mA max. to 225mA max.	
		11	Application Information: Added sections, "Power Supply Filtering Techniques" and "Wiring the Differential Level..."	
		12	Added "Differential Clock Input Interface" section.	
C	T2	5	Pin Characteristics - changed C _{IN} from 4pF max. to 4pF typical.	5/7/03
		10	Corrected Freeze Data labeling on Figure 2A.	
D	T4A	7	Power Supply Table - changed V _{DDA} minimum from 3.135V to 2.935V.	6/27/03
D	T1	4	Pin Characteristics Table - added Pullup/Pulldown to pin 12, nCLK.	7/9/03
	T2	5	Pin Characteristics Table - added to R _{OUT} 5Ω min. and 12Ω max.	
D	T9	1	Features section - added lead-free bullet.	5/19/06
		12	Added <i>Recommendations for Unused Input and Output Pins</i> .	
		15	Ordering Information Table - added lead-free part number, marking and note.	
D	T9	15	Updated datasheet's header/footer with IDT from ICS.	8/15/10
			Removed ICS"prefix from Part/Order Number column.	
		17	Added Contact Page.	
D	T9	15	Ordering Information - removed leaded devices, quantity for tape & reel and LF suffix note. Updated DS header and footer.	12/7/15

IMPORTANT NOTICE AND DISCLAIMER

RENESAS ELECTRONICS CORPORATION AND ITS SUBSIDIARIES (“RENESAS”) PROVIDES TECHNICAL SPECIFICATIONS AND RELIABILITY DATA (INCLUDING DATASHEETS), DESIGN RESOURCES (INCLUDING REFERENCE DESIGNS), APPLICATION OR OTHER DESIGN ADVICE, WEB TOOLS, SAFETY INFORMATION, AND OTHER RESOURCES “AS IS” AND WITH ALL FAULTS, AND DISCLAIMS ALL WARRANTIES, EXPRESS OR IMPLIED, INCLUDING, WITHOUT LIMITATION, ANY IMPLIED WARRANTIES OF MERCHANTABILITY, FITNESS FOR A PARTICULAR PURPOSE, OR NON-INFRINGEMENT OF THIRD PARTY INTELLECTUAL PROPERTY RIGHTS.

These resources are intended for developers skilled in the art designing with Renesas products. You are solely responsible for (1) selecting the appropriate products for your application, (2) designing, validating, and testing your application, and (3) ensuring your application meets applicable standards, and any other safety, security, or other requirements. These resources are subject to change without notice. Renesas grants you permission to use these resources only for development of an application that uses Renesas products. Other reproduction or use of these resources is strictly prohibited. No license is granted to any other Renesas intellectual property or to any third party intellectual property. Renesas disclaims responsibility for, and you will fully indemnify Renesas and its representatives against, any claims, damages, costs, losses, or liabilities arising out of your use of these resources. Renesas' products are provided only subject to Renesas' Terms and Conditions of Sale or other applicable terms agreed to in writing. No use of any Renesas resources expands or otherwise alters any applicable warranties or warranty disclaimers for these products.

(Disclaimer Rev.1.0 Mar 2020)

Corporate Headquarters

TOYOSU FORESIA, 3-2-24 Toyosu,
Koto-ku, Tokyo 135-0061, Japan
www.renesas.com

Contact Information

For further information on a product, technology, the most up-to-date version of a document, or your nearest sales office, please visit:
www.renesas.com/contact/

Trademarks

Renesas and the Renesas logo are trademarks of Renesas Electronics Corporation. All trademarks and registered trademarks are the property of their respective owners.