

# HFCT-711XPD

## Multi-rate 1310 nm XFP 10 Gbit/s Optical Transceiver

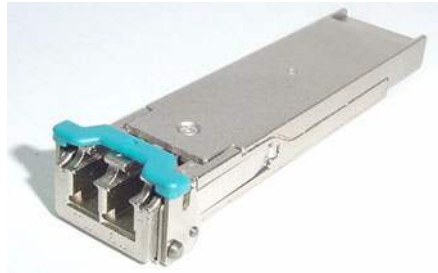

### Data Sheet



#### Description

The 1310 nm XFP transceiver is a high performance, cost effective module for serial optical data communications applications specified for signal rates of 9.95 Gb/s to 10.5 Gb/s. It is compliant to XFP MSA Rev 4.5. The module is designed for single mode fiber and operates at a nominal wavelength of 1310 nm. The transmitter section incorporates a directly modulated 1310 nm distributed feedback laser (DFB). The receiver section uses an MOVPE grown planar SEDET PIN photodetector for low dark current and excellent responsivity. Integrated Tx and Rx eye openers provide high jitter-tolerance and low jitter-generation and transfer for full XFI and SONET compliance. The internally ac coupled high speed serial I/O simplifies interfacing to external circuitry. The electrical interface is made using an industry standard 0.8 mm pitch 30-pin right angle connector. Optical connection is made via the duplex LC connector.

#### Features

- Compliant to XFP MSA
- Multi-protocol multi-bitrate compliant
  - Compliant to SONET/SDH OC-192/STM-64 rate 9.9532 Gb/s, Telcordia GR-253-CORE SR-1, ITU-T G.691 164.1
  - Compliant to IEEE 802.3ae 10GBASE-LR for 10GbE, 10.3125 Gb/s
  - Compliant to 10GFC 1310 nm Serial PMD, type 1200-SM-LL-L, 10.51875 Gb/s
  - Compatible with 10.7Gb/s and 11.3Gb/s operation for FEC functionality
- Uncooled 1310 nm DFB Laser and PIN Photodiode
- Compliant XFI 10G Serial electrical interface
- LC Duplex optical connector interface conforming to ANSI TIA/EIA604-10 (FOCIS 10)
- 1.5W typical power dissipation
- Superior Thermal and EMI performance to support high port densities

- Customizable clip-on heatsink to support a variety of line card environments
- -5 to +70 °C case operating temperature range
- Capable of extended temperature (-10°C to +85°C, Case temperature) operation\*\*
- Hardware pins are available for the following control signals:
  - Transmitter disable
  - Module power down/reset
  - Receiver loss of signal
  - Module not ready
  - programmable interrupt
- 2-wire serial management interface provides real time monitors of:
  - Transmitted Optical Power
  - Received Optical Power
  - Laser Bias Current
  - Module Temperature
  - Supply Voltage
  - Laser Temperature
- Link Lengths up to 10 km with 9 μm SMF
- IEC 60825-1 Class 1/CDRH Class 1 laser eye safe

Note:

\*\* Long term reliability at elevated temperatures is not guaranteed"

#### Applications

- Fiber Channel Switches
- Host Bus Adapter Cards
- Mass Storage System and Server I/O
- Optical Cross Connect Switches
  - Next generation SONET/SDH ADMs
  - Core Routers

The product offers digital diagnostics using the 2-wire serial interface defined in the XFP MSA. The product provides real time temperature (module and laser), supply voltage, laser bias current, laser average output power and received input power. The digital diagnostic interface also adds the ability to disable the transmitter (TX\_DIS), power down the module, monitor for module faults and monitor for Receiver Loss of Signal (RX\_LOS). Transmitter disable, interrupt, power down/reset, receiver loss of signal and module not ready are also hard wired pins on the 30-pin right angle connector.

### Installation

The HFCT-711XPD is hot-pluggable, allowing the module to be installed while the host system is operating and on-line. The attach heatsink is designed to clip on to the XFP cage without a module present.

Upon insertion, the transceiver housing makes initial contact with the host board XFP cage, mitigating potential damage due to Electro-Static Discharge (ESD). Once fully inserted into the XFP cage, the top surface of the XFP module makes contact with the heatsink through a cutout in the top of the cage ensuring an effective thermal path for module heat.

## Functional Description

### Transmitter Section

The transmitter section includes a 1310 nm DFB (Distributed Feedback Laser) light source, a transmitter driver circuit and a signal conditioner circuit on the TX data inputs. (See Figure 1) Optical connection to the transmitter is provided via a LC connector. The optical output is controlled by a custom IC that detects the laser output via the monitor photodiode. This IC provides both dc and ac current drive to the laser to ensure correct modulation, eye diagram and extinction ratio over temperature, supply voltage and operating life.

#### TX\_DIS

Asserting pin 5, TX\_DIS, will disable the transmitter optical output. The transmitter output can also be disabled and monitored via the two-wire serial.

#### Eye Safety Circuit

Under normal operating conditions laser power will be maintained below Class 1 eye-safety limits. Should a catastrophic laser fault occur and optical power become uncontrolled, the micro-controller will detect the fault, shut down the laser, power down the module and assert the hard-wired MOD\_NR flag. The TX\_FAULT output in the 2-wire serial interface will also be asserted.

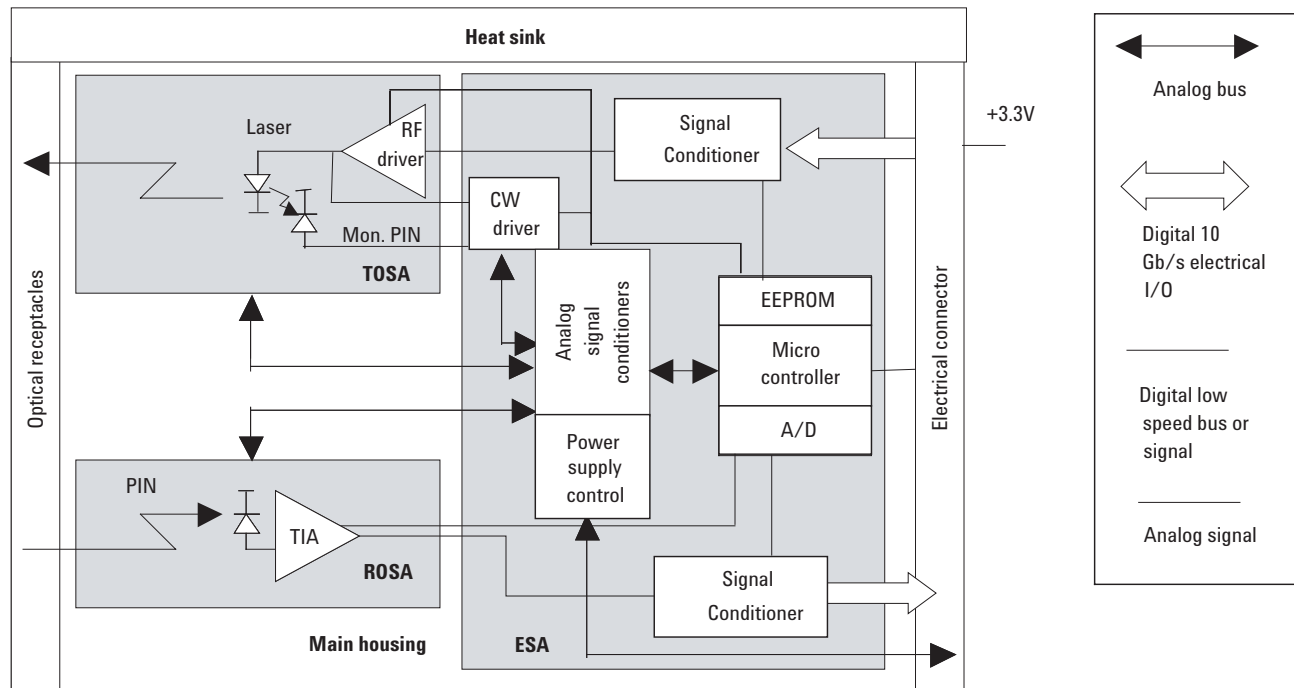

Figure 1. Transceiver Functional Diagram

## Receiver Section

The receiver section includes a PIN detector with amplification, quantization and signal conditioner circuits. (See Figure 1) Optical connection to the receiver is provided via a LC optical connector.

### RX\_LOS

The receiver section contains a loss of signal (RX\_LOS) circuit to indicate when the optical input signal power is insufficient for reliable signal detection. A high signal indicates loss of modulated signal, indicating link failure such as a broken fiber or nonfunctional remote transmitter. RX\_LOS can also be monitored via the two-wire serial interface (byte 110, bit 1).

## Functional Data I/O

Avago Technologies' HFCT-711XPD fiber-optic transceiver is designed to accept industry standard electrical input differential signals. The transceiver provides ac-coupled, internally terminated data input and output interfaces. Bias resistors and coupling capacitors have been included within the module to reduce the number of components required on the customer's board.

## Electrical Pinout

Top surface of edge connector on module		Bottom surface of edge connector on module	
		GND	15
16	GND	RX_LOS	14
17	RD-	MOD_NR	13
18	RD+	MOD_ABS	12
19	GND	SDA	11
20	VCC2	SCL	10
21	P_DOWN/RST	VCC3	9
22	VCC2	VCC3	8
23	GND	GND	7
24	REFCLK+	VCC5	6
25	REFCLK-	TX_DIS	5
26	GND	INTERRUPT	4
27	GND	MOD_DESEL	3
28	TD-	VEE5	2
29	TD+	GND	1
30	GND		

Figure 4. Host PCB XFP Pinout Top View

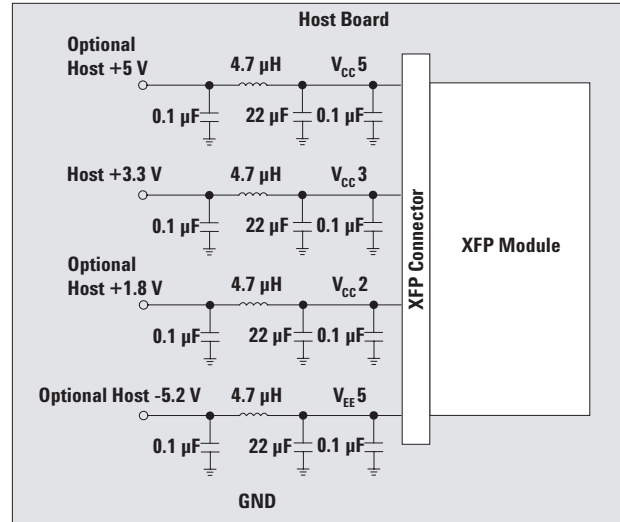

Figure 2. MSA Recommended Power Supply Filter

**Table 1. Electrical Pin Definitions**

Pin	Name	Logic	Function/Description	Notes
1	GND		Module Ground	1
2	V <sub>EE5</sub>		-5.2 V power supply. (Not Used)	
3	Mod-Desel	LVTTTL-I	Module De-select; When held low allows the module to respond to 2-wire Serial interface commands	
4	Interrupt	LVTTTL-0	Interrupt; Indicates presence of an important condition which can be read over the serial 2-wire interface	2
5	TX_DIS	LVTTTL-I	Transmitter Disable; Transmitter Laser Source Turned Off	
6	V <sub>CC5</sub>		5 V power supply. (Not Used)	
7	GND		Module Ground	1
8	V <sub>CC3</sub>		+3.3 V Power Supply	
9	V <sub>CC3</sub>		+3.3 V Power Supply	
10	SCL	LVTTTL-I	Two Wire Interface Clock	2
11	SDA	LVTTTL-I/O	Two Wire Interface Data Line	2
12	Mod_Abs	LVTTTL-0	LVTTTL-0 Mod_Abs Indicates Module is not present. Grounded in the Module	2
13	Mod_NR	LVTTTL-0	Module Not Ready; Indicating Module Operational Fault	2
14	RX_LOS	LVTTTL-0	Receiver Loss Of Signal Indicator	2
15	GND		Module Ground	1
16	GND		Module Ground	1
17	RD-	CML-0	Receiver Inverted Data Output	
18	RD+	CML-0	Receiver Non-Inverted Data Output	
19	GND		Module Ground	1
20	V <sub>CC2</sub>		+1.8 V Power Supply (Not Used)	
21	P_Down/RST	LVTTTL-I	Power down: When high, the module is put into a low power mode. Serial interface is functional in the low power mode. Reset: The falling edge initiates a complete reset of the module including the serial Interface, equivalent to a power cycle.	
22	V <sub>CC2</sub>		+1.8 V Power Supply (Not Used)	1
23	GND		Module Ground	
24	RefCLK+	PECL-I	Reference Clock Non-Inverted Input, ac coupled on the host board (Not Used)	
25	RefCLK-	PECL-I	Reference Clock Inverted Input, ac coupled on the host board (Not Used)	3
26	GND		Module Ground	1, 3
27	GND		Module Ground	1
28	TD-	CML-I	Transmitter Inverted Data Input	
29	TD+	CML-I	Transmitter Non-Inverted Data Input	
30	GND		Module Ground	1

**Notes:**

1. Module ground pins Gnd are isolated from the module case and chassis ground within the module.
2. Open Collector should be pulled up with 4.7 k-10 kOhms to a voltage between 3.15 V and 3.6 V on the host board.
3. RefCLK+/- are internally terminated (50Ω)

## Absolute Maximum Ratings

Parameter	Symbol	Minimum	Typical	Maximum	Unit	Notes
Storage Temperature (non-operating)	$T_S$	-40		+85	°C	1, 2, 3
Ambient Operating Temperature	$T_A$	-40		+85	°C	1, 2, 3
Relative Humidity	RH	10		90	%	1
Supply Voltage	$V_{CC3}$			3.6	V	1, 2
Low Speed Input Voltage	$V_{IN}$	-0.5		$V_{CC}+0.5$	V	1

## Recommended Operating Conditions

Parameter	Symbol	Minimum	Typical	Maximum	Unit	Notes
Case Operating Temperature	$T_C$	-5		+70	°C	3
Supply Voltage	$V_{CC3}$	3.135		3.465	V	4, 5
Data Rate		9.95		10.52	Gb/s	4

## Transceiver Electrical Characteristics

( $T_C = -5\text{ °C}$  to  $+70\text{ °C}$ ,  $V_{CC3} = 3.3\text{ V} \pm 5\%$ )

Parameter	Symbol	Minimum	Typical	Maximum	Unit	Notes
Power Supply Noise Rejection (peak-peak) under 1MHz	PSNR			2% of $V_{CC}$	mV	6
Power Supply Noise Rejection (peak-peak) 1MHz to 10 MHz	PSNR			3% of $V_{CC}$	mV	6
Module supply current	$I_{CC}$		396	605 (EOL)	mA	
Power Dissipation	$P_{DISS}$		1307	2100 (EOL)	mW	
<b>Low Speed Outputs:</b> MOD_NR, RX_LOS, MOD_ABS, INTERRUPT	$V_{OH}$ $V_{OL}$	Host_ $V_{CC}-0.5$ 0.0		Host_ $V_{CC}+0.3$ 0.4	V V	7 8
<b>Low Speed Inputs:</b> TX_DIS, MOD_DESEL, P_DOWN/RST	$V_{IH}$ $V_{IL}$	2.0 -0.5		$V_{CC3}+0.3$ 0.8	V V	9 10

### Notes:

1. Absolute Maximum Ratings are those values beyond which damage to the device may occur if these limits are exceeded for other than a short period of time. See Reliability Data Sheet for specific reliability performance.
2. Between Absolute Maximum Ratings and the Recommended Operating Conditions functional performance is not intended, device reliability is not implied, and damage to the device may occur over an extended period of time.
3. The Ambient Operating Temperature limitations are based on the Case Operating Temperature limitations and are subject to the host system thermal design.
4. Recommended Operating Conditions are those values for which functional performance and device reliability is implied
5.  $V_{CC}$  condition applies to supply voltage at the XFP module
6. Power Supply filtering on host board required as per XFP MSA specification
7. 4.7 k to 10 k $\Omega$  resistor pull-up to host\_  $V_{CC}$ , measured at the host side of connector.  $I_{OH(max)} = -2\text{ mA}$ .
8. 4.7 k to 10 k $\Omega$  resistor pull-up to host\_  $V_{CC}$ , measured at the host side of connector.  $I_{OL(max)} = 2\text{ mA}$ .
9. 4.7 k to 10 k $\Omega$  resistor pull-up to host\_  $V_{CC}$ , measured at the host side of connector.  $I_{OL(max)} = 10\text{ }\mu\text{A}$ .
10. 4.7 k to 10 k $\Omega$  resistor pull-up to host\_  $V_{CC}$ , measured at the host side of connector.  $I_{IH(max)} = -10\text{ }\mu\text{A}$ .

## Transmitter Electrical Input Characteristics

( $T_C = -5\text{ }^\circ\text{C}$  to  $+70\text{ }^\circ\text{C}$ ,  $V_{CC3} = 3.3\text{ V} \pm 5\%$ )

Parameter	Symbol	Minimum	Typical	Maximum	Unit	Notes
Differential Input Impedance	$Z_d$		100		$\Omega$	
Termination Mismatch	$DZ_M$			5	%	
Differential Input Amplitude	DVQD0	120		820	mV	peak to peak (1)
Differential Input Return Loss	SDD11	20			dB	0.05 to 0.1 GHz
Differential Input Return Loss	SDD11	8			dB	0.1 to 5.5 GHz
Differential Input Return Loss	SDD11	$8 - 20.66 \log_{10}(f/5.5)$			dB	5.5 - 12 GHz
Common Mode Input Return Loss	SCC11	3			dB	0.1 to 15 GHz
Differential to Common Mode Conversion	SCD11			-10	dB	0.1 to 15 GHz
Jitter and Eye Mask						XFP MSA Compliant

## Receiver Electrical Output Characteristics

Parameter	Symbol	Minimum	Typical	Maximum	Unit	Notes
Differential Output Impedance	$Z_d$		100		$\Omega$	
Termination Mismatch	$DZ_M$			5	%	
Differential Output Amplitude	DVQD0	340		850	mV	peak to peak (1)
DC Common Mode Potential	$V_{cm}$	0		3.6	V	
Output AC Common Mode Voltage				15	mV	RMS
Output Rise/Fall time (20% to 80%)	$t_r, t_f$	24			ps	
Common mode output return loss	SCC22	3			dB	0.1 to 15 GHz
Differential output return loss	SDD22	20			dB	0.05 to 0.1 GHz
Differential output return loss	SDD22	8			dB	0.1 to 5.5 GHz
Differential output return loss	SDD22	$8 - 20.66 \log_{10}(f/5.5)$ f in GHz			dB	5.5 to 12 GHz
Jitter and Eye Mask						XFP MSA Compliant

### Notes:

1. The differential input and output amplitudes are per XFP MSA Rev 4.5 mask at points B' and C'.

### Transmitter Optical Characteristics 10 GbE/10GFC

( $T_C = -5\text{ }^\circ\text{C}$  to  $+70\text{ }^\circ\text{C}$ ,  $V_{CC3} = 3.3\text{ V} \pm 5\%$ )

Parameter	Symbol	Minimum	Typical	Maximum	Unit	Notes
Optical Output Power	$P_{OMA}$	-5.2			dBm OMA	1, 2
Average Optical Output Power	$P_{out}$	-8.2		0.5	dBm	1, 2, 3
Extinction Ratio	ER	3.5			dB	1, 2
Spectral Width - rms	s, rms			0.2	nm RMS	3
Center Wavelength	$\lambda_c$	1260	1310	1355	nm	
Transmitter and dispersion penalty	TDP			3.2	dB	1, 2
Side mode suppression ratio		30			dB	1
Optical output power (min) in OMA - TDP		-6.2			dBm OMA	1, 2
$RIN_{12}$ (OMA)	RIN			-128	dB/Hz	1
Optical eye mask	Compliant with IEEE 802.3ae 10GBASE-LR					

### Receiver Optical Characteristics 10 GbE/10GFC

( $T_C = -5\text{ }^\circ\text{C}$  to  $+70\text{ }^\circ\text{C}$ ,  $V_{CC3} = 3.3\text{ V} \pm 5\%$ )

Parameter	Symbol	Minimum	Typical	Maximum	Unit	Notes
Average Receive power		-14.4		0.5	dBm mean	1
Stressed receiver sensitivity				-10.3	dBm OMA	1
Receiver sensitivity	$P_{IN}$			-12.6	dBm OMA	3
Max Receiver Reflectance				-12	dB	1
Wavelength	$\lambda_c$	1260	1310	1355	nm	
Jitter Tolerance Compliant with XFP MSA Rev 4.5						

### Transmitter Optical Characteristics OC-192 SONET SR-1

( $T_C = -5\text{ }^\circ\text{C}$  to  $+70\text{ }^\circ\text{C}$ ,  $V_{CC3} = 3.3\text{ V} \pm 5\%$ )

Parameter	Symbol	Minimum	Typical	Maximum	Unit	Notes
Optical Output Power	$P_0$	-6		-1	dbm	4
Extinction Ratio	ER	6			dB	
Spectral Width @ 20 dB	s			1	nm	5
Center Wavelength	$\lambda_c$	1290	1310	1330	nm	
Side mode suppression ratio	SMSR	30			dB	
Output Optical Eye Mask	Compliant with Telcordia GR-253-CORE, ITU-T G.691					
Jitter Generation (RMS)	$T_j$ rms			10	mUI	6
Jitter Generation (peak-to-peak)	$T_j$ pp			100	mUI	6
Jitter Transfer	Compliant with XFP MSA					

#### Notes:

- 10GFC 1200-SM-LL-L / IEEE 802.3ae 10BASE-LR compliant
- These parameters are interrelated: see IEEE 802.3ae
- For information only
- The output power is coupled into a 1 m single mode fiber. Minimum output optical level is at end of life.
- Measured 20 dB down from the maximum of the central wavelength peak
- Measured over frequency range 50 kHz to 80 MHz. Supports compliance to both GR-253-CORE and ITU-T G.783 specifications. Guarantee 100mUI p-p and 10mUI rms (50MHz-80MHz) when plugged into an XFI compliant interface

### Receiver Optical Characteristics OC-192 SONET SR-1

( $T_C = -5\text{ }^\circ\text{C}$  to  $+70\text{ }^\circ\text{C}$ ,  $V_{CC3} = 3.3\text{ V} \pm 5\%$ )

Parameter	Symbol	Minimum	Typical	Maximum	Unit	Notes
Receiver sensitivity	$P_{IN(MIN)}$		-17.3 (BOL, ER =6 dB)	-11	dBm	1
Receiver overload	$P_{IN(MAX)}$			-1	dBm	1
Max Receiver Reflectance				-14	dB	
Input Operating Wavelength		1290		1330	nm	
Jitter Tolerance	Compliant with GR-253 and ITU-T G.783 masks.					
Jitter Transfer	Compliant with XFP MSA.					



## Transceiver Timing Characteristics

( $T_C = -5\text{ }^\circ\text{C}$  to  $+70\text{ }^\circ\text{C}$ ,  $V_{CC3} = 3.3\text{ V} \pm 5\%$ )

Parameter	Symbol	Min	Typ	Max	Unit	Notes
TX_DIS Assert Time	t_off			10	$\mu\text{s}$	Time from rising edge of TX_DIS to when the optical output falls below 10% of nominal.
TX_DIS Negate Time	t_on			2	ms	Time from falling edge of TX_DIS to when the modulated optical output rises above 90% of nominal.
Time to initialize	t_init			300	ms	From power on or hot plug after meeting power supply specs
Interrupt assert delay	Interrupt_on			200	ms	From occurrence of the condition triggering interrupt
Interrupt negate delay	Interrupt_off			500	$\mu\text{s}$	From clear on read interrupt flags
P_Down/RST assert delay	P_Down/RST_on			100	$\mu\text{s}$	From Power down initiation
P-Down negate delay	P_Down/RST_off			300	ms	Max delay from negate to completion of power up and reset
Mod_NR assert delay	Mod_nr_on			1	ms	From Occurrence of fault to assertion of TX_NR
Mod_NR negate delay	Mod_nr_off			1	ms	From Occurrence of signal to negation of TX_NR
Mod_DeSel assert time	T_Mod_DeSel			2	ms	Maximum delay between assertion of Mod_DeSel and end of module response to 2-wire interface communications
Mod_DeSel de-assert time	T_Mod_Sel			2	ms	Maximum delay between de-assertion of Mod_DeSel and proper module response to 2-wire interface communications
P_Down reset time	t_reset	10			$\mu\text{s}$	Min length of P-Down assert to initial reset
RX_LOS Assert delay	T_loss_on			100	$\mu\text{s}$	From Occurrence of loss of signal to assertion of RX_LOS
RX_LOS negate delay	T_loss_off	2.3		100	$\mu\text{s}$	From Occurrence of presence of signal to negation of RX_LOS
Serial ID Clock Rate	f_serial_clock	0		400	kHz	

### Notes:

1. BER no worse than  $1 \times 10^{-12}$

## Digital Diagnostic Interface and Serial Identification

The 2-wire serial interface is explicitly defined in the XFP MSA document and is designed to be compatible with I2C host controllers. 2-wire timing specifications and the structure of the memory map are per XFP MSA Rev 4.0. The normal 256 Byte I2C address space is divided into lower and upper blocks of 128 Bytes. The lower block of 128 Bytes is always directly available and is used for diagnostic information providing the opportunity for Predictive Failure Identification, Compliance Prediction, Fault Isolation and Component Monitoring. The upper address space tables are used for less frequently accessed functions such as serial ID, user writeable EEPROM, reserved EEPROM and diagnostics and control spaces for future standards definition, as well as Avago Technologies specific functions.

### Predictive Failure Identification

The diagnostic information allows the host system to identify potential link problems. Once identified, a "fail over" technique can be used to isolate and replace suspect devices before system uptime is impacted.

### Compliance Prediction

The real-time diagnostic parameters can be monitored to alert the system when operating limits are exceeded and compliance cannot be ensured. As an example, the real time average receive optical power can be used to assess the compliance of the cable plant and remote transmitter.

### Fault Isolation

The diagnostic information can allow the host to pinpoint the location of a link problem and accelerate system servicing and minimize downtime.

### Component Monitoring

As part of host system qualification and verification, real time transceiver diagnostic information can be combined with system level monitoring to ensure performance and operating environment are meeting application requirements.

### Transceiver Internal Temperature

Temperature is measured on the HFCT-711XPD using sensing circuitry mounted on the internal PCB. The measured temperature will generally be cooler than laser junction and warmer than XFP case and can be indirectly correlated to XFP case or laser junction temperature using thermal resistance and capacitance modeling. This measurement can be used to observe drifts in thermal operating point or to detect extreme temperature fluctuations such as a failure in the system thermal control. For more information on correlating internal temperature to case or laser junction contact Avago Technologies.

### Transmitter Laser dc Bias Current

Laser bias current is measured using sensing circuitry located on the transmitter laser driver IC. Normal variations in laser bias current are expected to accommodate the impact of changing transceiver temperature and supply voltage operating points. The HFCT-711XPD uses a closed loop laser bias feedback circuit to maintain constant optical power and extinction ratio. This circuit compensates for normal laser parametric variations in quantum efficiency, forward voltage and lasing threshold due to changing transceiver operating points.

### Transmitted Average Optical Output Power

Variations in average optical power are *not* expected under normal operation because the HFCT-711XPD uses a closed loop laser bias feedback circuit to maintain constant optical power. This circuit compensates for normal laser parametric variations due to changing transceiver operating points. Only under extreme laser bias conditions will significant drifting in transmitted average optical power be observable. Therefore it is recommended Tx average optical power be used for fault isolation, rather than predictive failure purposes.

### Received Average Optical Input Power

Received average optical power measurements are a valuable asset for installers to verify cable plant compliance. Drifts in average power can be observed from the cable plant and remote transmitter for potential predictive failure use. Received average optical power can be used for fault isolation.

### Auxilliary Monitors

In addition to the parameters mentioned above, Laser Temperature and Supply Voltage are also reported as auxilliary parameters

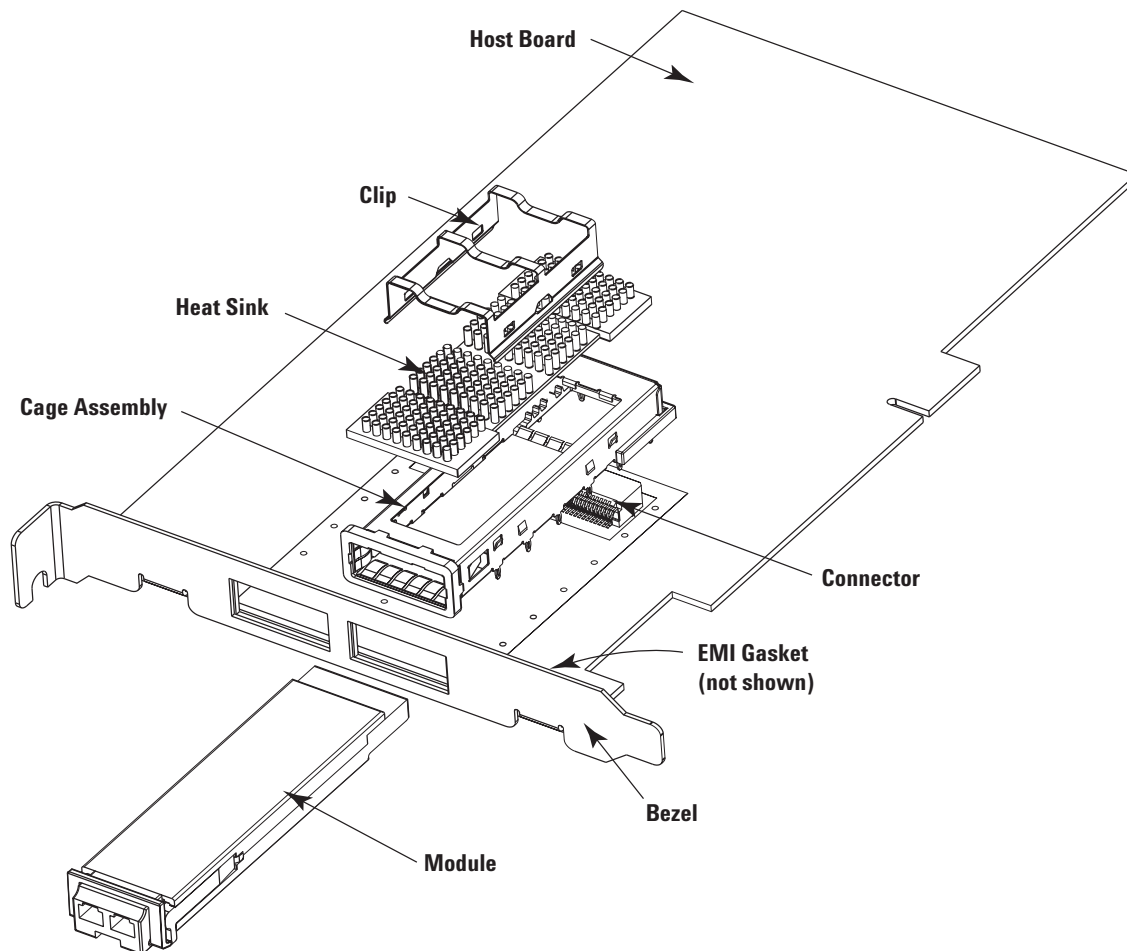

Figure 5. XFP Assembly Drawing

# Mechanical Specifications

## Package Dimensions

- 1 MODULE DETAIL CONTINUED IN FIG 23 AND  
DETAIL OF MODULE P.C.B. FIG 24.
- 2 INDICATED DIMENSIONS DEFINE ENLARGED  
SECTION OF TRANSDUCER TO ACCOMMODATE MATING  
PLUG AND ACTUATOR MECHANISM. A BAIL ACTUATOR  
IS THE PREFERRED DESIGN.
- 3 FLATNESS APPLIES FOR INDICATED LENGTH.  
SURFACE TO BE THERMALLY CONDUCTIVE.
- 4 RADIUS APPLIES TO MODULE BODY.
- 5 INDICATED SURFACES (ALL FOUR SIDES) TO BE  
CONDUCTIVE FOR CONNECTION TO CHASSIS GROUND.
- 6 SEE FIGURE 23.
- 7 DIMENSION APPLIES TO LATCH MECHANISM.  
(SEE FIG.23)

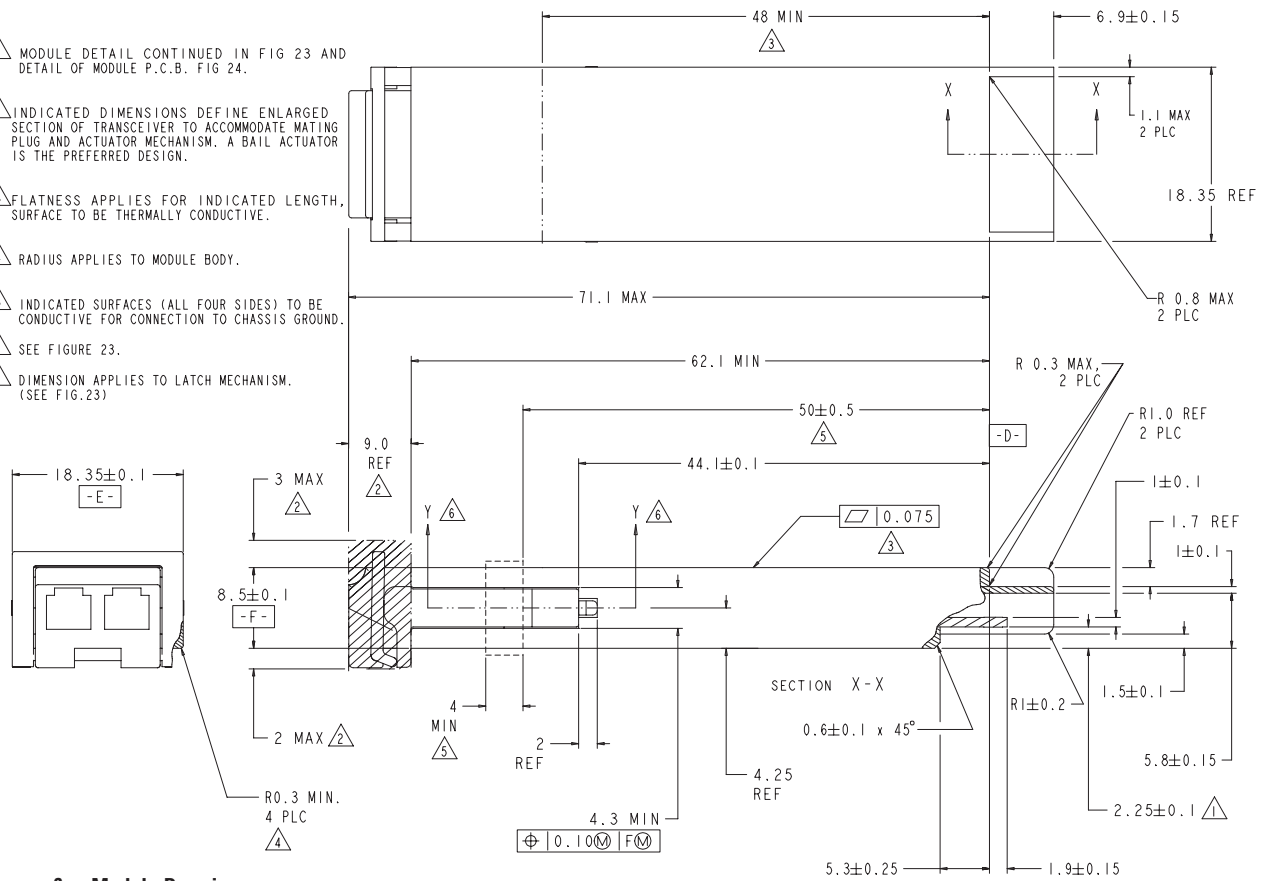

Figure 6a. Module Drawing

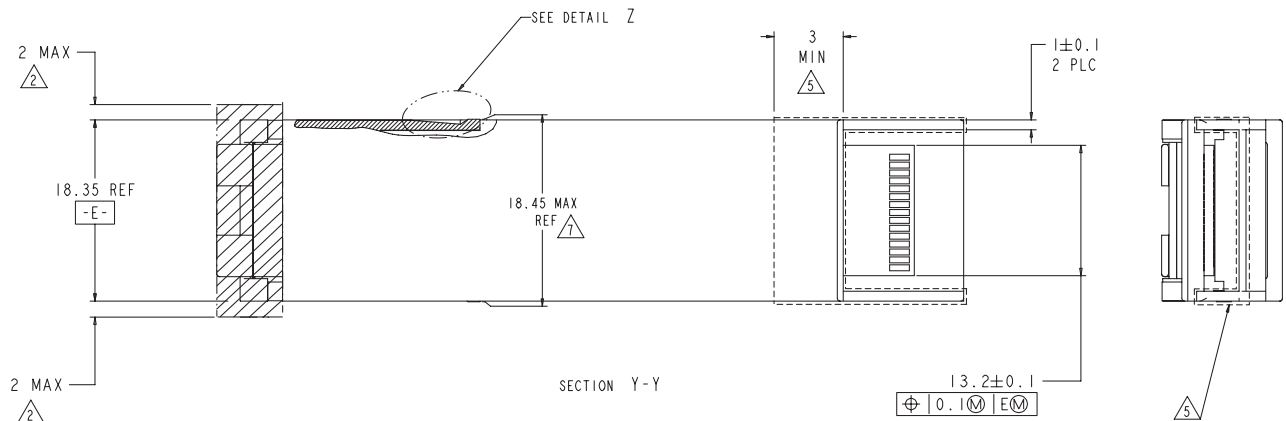
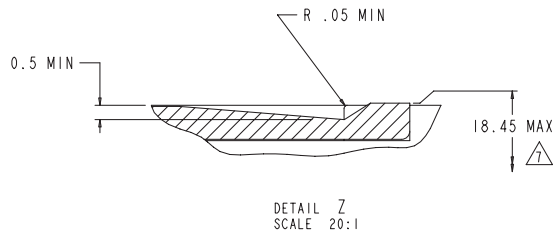

Figure 6b. Module Drawing

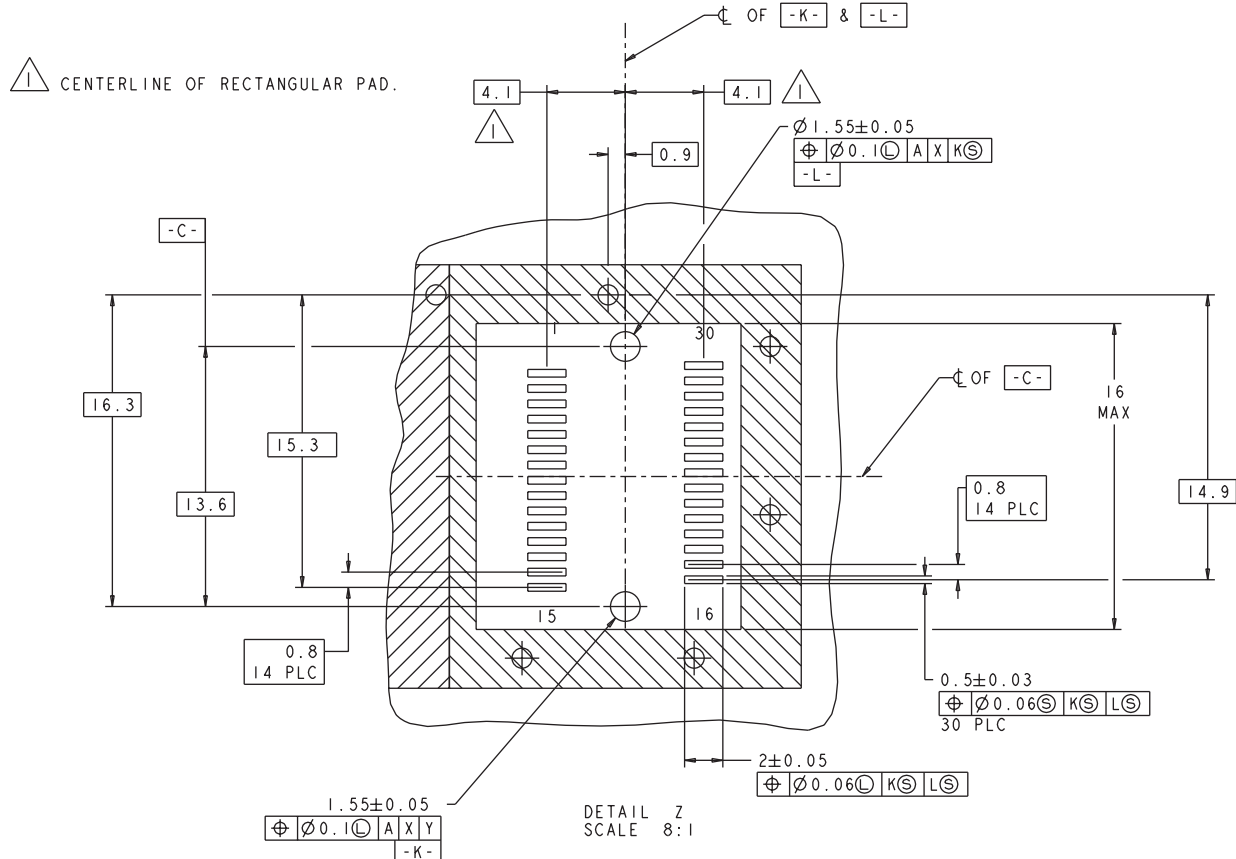
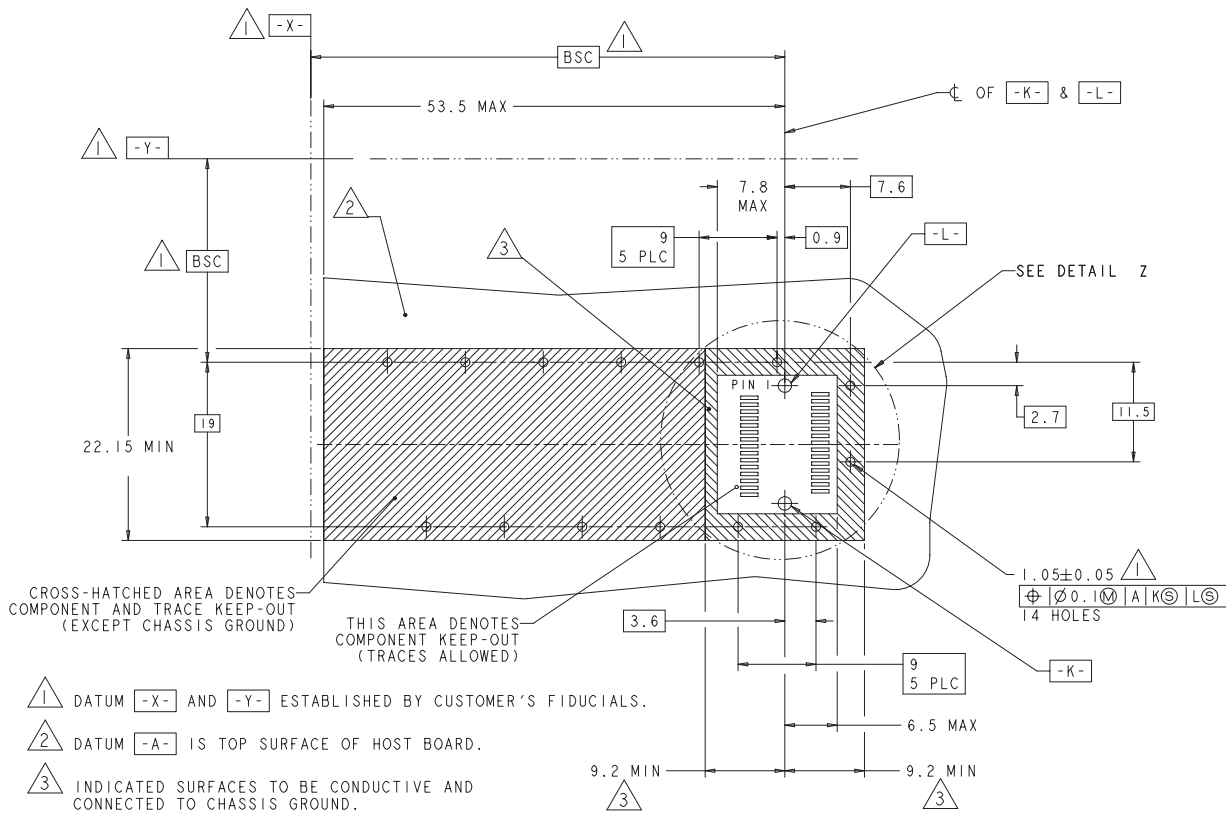

Figure 7. XFP host board mechanical layout

## Application Support

An Evaluation Kit and Reference Designs are available to assist in evaluation of the HFCT-711XPD. Please contact your local Field Sales representative for availability and ordering details.

## Regulatory Compliance

The transceiver Regulatory Compliance performance is provided in Table 2 as a figure of merit to assist the designer. The overall equipment design will determine the certification level.

### Electrostatic Discharge (ESD)

There are two conditions in which immunity to ESD damage is important. Table 13 documents the ESD immunity to both of these conditions.

The first condition is static discharge to the transceiver during handling such as when the transceiver is inserted into the transceiver port. To protect the transceiver, it is important to use normal ESD handling precautions including the use of grounded wrist straps, work benches, and floor mats in ESD controlled areas. The ESD sensitivity

of the HFCT-711XPD is compatible with typical industry production environments.

The second condition is static discharge to the exterior of the host equipment chassis after installation. To the extent that the duplex LC optical interface is exposed to the outside of the host equipment chassis, it may be subject to system-level ESD requirements.

The ESD performance of the HFCT-711XPD exceeds typical industry standards.

### Immunity

The transceivers have a shielded design to provide excellent immunity to radio-frequency electromagnetic fields which may be present in some operating environments.

### Electromagnetic Interference (EMI)

Most equipment designs using the HFCT-711XPD are subject to the requirements of the FCC in the United States, CENELEC EN55022 (CISPR 22) in Europe and VCCI in Japan. The metal housing and shielded design of the HFCT-711XPD minimizes EMI and provides excellent EMI performance.

**Table 2. Regulatory Compliance**

Feature	Test Method	Performance
Electrostatic Discharge (ESD) to the exterior of the XFP module	JEDEC JESD22-A114-B	1000 Volts
Electrostatic Discharge (ESD) to the Optical Connector	GR1089	10 discharges of both polarities of 8 kV on the electrical faceplate with device inserted into a panel.
Electrostatic Discharge (ESD) to the Optical Connector	Variation of IEC 801-2	Air discharge of 15 kV(min) contact to connector w/o damage
Electromagnetic Interference (EMI)	FCC Class B CENELEC EN55022 Class B (CISPR 22A) VCCI Class 1	System margins are dependent on customer board and chassis design.
Immunity	Variation of IEC 61000-4-3	Less than 0.5 dB of Rx sensitivity degradation and less than 10% margin reduction of Tx mask at 10 V/m, 10 MHz to 1 GHz w/o chassis enclosure
Laser Eye Safety and Equipment Type Testing	US FDA CDRH AEL Class 1 US21 CFR, Subchapter J per Paragraphs 1002.10 and 1002.12.  (IEC) EN60825-1: 1994 + A11+A2 (IEC) EN60825-2: 1994 + A1 (IEC) EN60950: 1992 + A1 + A2 + A3 + A4 + A11	CDRH certification # 9521220-100 TUV file # 933/510312/02
Component Recognition	Underwriters Laboratories and Canadian Standards Association Joint Component Recognition for Information Technology Equipment Including Electrical Business Equipment	UL certificate number 05012004-E173874

## **Eye Safety**

The HFCT-711XPD transceivers provide Class 1 eye safety by design. Avago Technologies has tested the transceiver design for regulatory compliance, under normal operating conditions and under single fault conditions. See Table 2.

## **Flammability**

The HFCT-711XPD is compliant to UL 94V-0.

## **Customer Manufacturing Processes**

The module is pluggable and is not designed for aqueous wash, IR reflow or wave soldering processes.

## **Caution**

The HFCT-711XPD contains no user serviceable parts. Tampering with or modifying the performance of the HFCT-711XPD will result in voided product warranty. It may also result in improper operation of the HFCT-711XPD circuitry, and possible overstress of the laser source. Device degradation or product failure may result. Connection of the HFCT-711XPD to a non-approved optical source, operating above the recommended absolute maximum conditions may be considered an act of modifying or manufacturing a laser product. The person(s) performing such an act is required by law to recertify and reidentify the laser product under the provisions of U.S. 21 CFR (Subchapter J) and the TUV.

## **Ordering Information**

Please contact your local field sales engineer or one of Avago Technologies franchised distributors for ordering information. For technical information, please visit Avago Technologies' WEB page at [www.avagotech.com](http://www.avagotech.com). For information related to XFP MSA documentation visit [www.xfpmsa.org](http://www.xfpmsa.org)

For product information and a complete list of distributors, please go to our web site: [www.avagotech.com](http://www.avagotech.com)

Avago, Avago Technologies, and the A logo are trademarks of Avago Technologies, Limited in the United States and other countries. Data subject to change. Copyright © 2006 Avago Technologies Pte. All rights reserved. Obsoletes 5989-2379EN AV01-0126EN - May 3, 2006

**AVAGO**  
TECHNOLOGIES