

# HGN-336 IEC 60320 INLET SOCKET WITH SWITCH, SNAP-IN



## FEATURES

The HGN-336 power entry module features an IEC Connector and a two-pole switch. The unit protects electronic equipment against malfunction due to fast common-mode and differential mode interferences. Designed for labor saving snap-in mounting. These filters are also available for Medical equipment with low leakage current.

## APPLICATIONS

Computer & networking equipment, Measuring & control equipment, Data processing equipment, laboratory instruments, Switching power supplies, other electronic equipment.

## TECHNICAL DATA

- Rated Voltage: 115/250VAC
- Rated Current: 1A, 2A, 3A, 4A, 6A,
- Power Line Frequency: 50/60Hz
- Max. Leakage Current each  
Line to Ground:
  - @ 250VAC 50Hz: 0.5mA, max
  - @ 250VAC 50Hz:  $2\mu A^*$ , max
- Hipot Rating (one minute)
  - Line to Ground: 2250VDC
  - Line to Line: 1450VDC
- Temperature Range: -25C to +85C

\* Medical application

## MECHANICAL DIMENSIONS (Unit: mm)

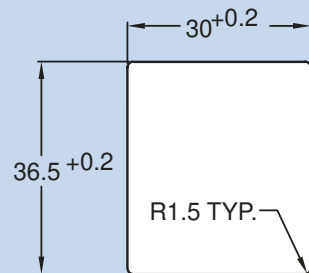
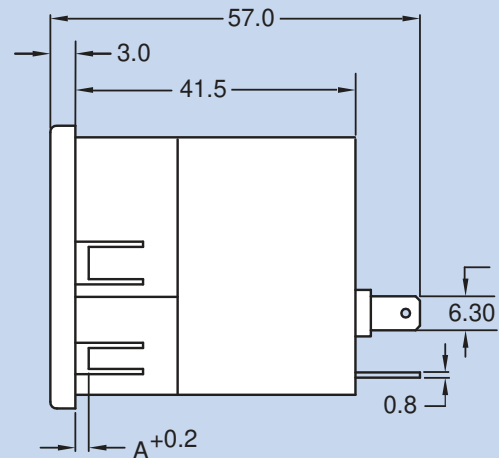
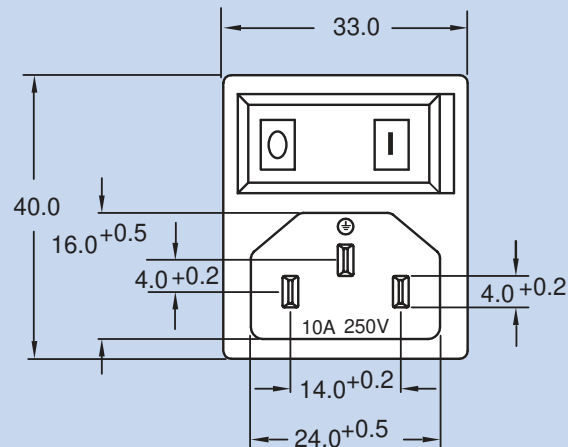

RECOMMENDED  
PANEL CUTOUT

Specifications subject to change without notice. Dimensions (mm). See Appendix A for recommended power cord. See PDI full line catalog for detailed specifications on power cords.

# HGN-336 Series Example & Ordering Code

HGN-336- 1 M - F - 150

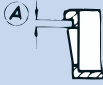
CURRENT RATING (A):	= 1 = 2 = 3 = 4 = 6	
		
SCHMATIC:	STANDARD TYPE = BLANK WITHOUT C(Y); C(X) ONLY = M	
TERMINAL:	QUICK CONNECT (6.3 x 0.8) = F	
PANEL THICKNESS*:	 0.06 (1.5MM) = 150 0.062 (1.6MM) = 160 0.08 (2.0MM) = 200	

\* More panel thickness options are available upon request

## Attenuation Tables & Schematics

### Non-Medical Applications

Insertion loss in dB (50 Ohm circuit)

Current Rating	L Value	Comm.Mode(L-G) MHz								Diff. mode(L-L) MHz							
		.01	.05	.15	.5	1	5	10	30	.01	.05	.15	.5	1	5	10	30
1A	10.3mA	18	30	40	58	50	50	65	28	9	13	13	45	65	70	60	30
2A	4.6mA	12	25	35	49	49	50	65	30	10	14	16	40	60	70	60	30
3A	2.5mA	5	20	30	41	48	54	60	34	10	14	19	31	54	70	64	35
4A	1.2mA	5	14	21	35	40	50	70	30	9	14	19	20	45	70	60	30
6A	0.8mA	3	10	20	30	34	45	55	35	9	14	19	19	40	70	60	35

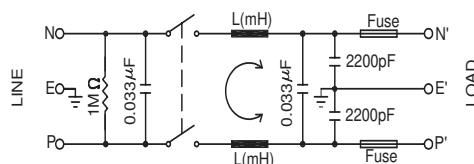

### Medical Applications

Insertion loss in dB (50 Ohm circuit)

Current Rating	L Value	Comm.Mode(L-G) MHz								Diff. mode(L-L) MHz							
		.01	.05	.15	.5	1	5	10	30	.01	.05	.15	.5	1	5	10	30
1A	10.3mA	22	32	41	51	48	37	31	22	9	11	15	50	67	82	71	37
2A	4.6mA	18	30	38	40	42	36	30	21	9	11	11	42	67	82	75	38
3A	2.5mA	18	28	33	38	38	30	23	18	9	15	14	38	55	82	76	35
4A	1.2mA	10	18	23	30	32	32	30	22	9	13	19	19	44	82	79	40
6A	0.8mA	8	13	19	27	29	29	29	25	9	18	21	19	47	84	82	50

