

Click [here](#) for production status of specific part numbers.

## MAX5871

# 16-Bit, 5.9Gbps Interpolating and Modulating RF DAC with JESD204B Interface

### General Description

The MAX5871 high-performance interpolating and modulating 16-bit 5.9Gbps RF DAC can directly synthesize up to 600MHz of instantaneous bandwidth from DC to frequencies greater than 2.8GHz. The device enables multi-standard and multi-band transmitters in wireless communications applications. The device meets spectral mask requirements for a broad set of communication standards including multicarrier GSM, UMTS, and LTE.

The device integrates interpolation filters, a digital quadrature modulator, a numerically controlled oscillator (NCO), clock multiplying PLL+VCO and a 14-bit RF DAC core. The user-configurable 5x, 6x, 6.67x, 8x, 10x, 12x, 13.33x, 16x, 20x or 24x, linear phase interpolation filters simplify reconstruction filtering, while enhancing passband dynamic performance, and reduce the input data bandwidth required from an FPGA/ASIC. The NCO allows for fully agile modulation of the input baseband signal for direct RF synthesis.

The MAX5871 accepts 16-bit input data via a four-lane JESD204B SerDes data input interface that is Subclass-0 and Subclass-1 compliant. The interface can be configured for 1, 2, or 4 lanes and supports data rates up to 10Gbps per lane allowing flexibility to optimize the I/O count and speed.

The MAX5871 clock input has a flexible clock interface and accepts a differential sine-wave, or square-wave input clock signal. A bypassable clock multiplying PLL and VCO can be used to generate a high-frequency sampling clock. The device outputs a divided reference clock to ensure synchronization of the system clock and DAC clock. In addition, multiple devices can be synchronized using JESD204B Subclass-1.

The MAX5871 uses a differential current-steering architecture and can produce a 0dBm full-scale output signal level with a 50Ω load. Operating from 1.8V and 1.0V power supplies, the device consumes 2.5W at 4.9Gbps. The device is offered in a compact 144-pin, 10mm x 10mm, FCCSP package and is specified for the extended industrial temperature range (-40°C to +85°C).

**Ordering Information** appears at end of data sheet.

### Benefits and Features

- Simplifies RF Design and Enables New Wireless Communication Architectures
  - Eliminates I/Q Imbalance and LO Feedthrough
  - Enables Multi-Band RF Modulation
- Direct RF Synthesis of 600MHz Bandwidth Up to 2.8GHz
  - 5.898Gbps DAC Output Update Rate
  - High-Performance 14-Bit RF DAC Core
  - Digital Quadrature Modulator and NCO with 1Hz/10Hz/100Hz/1kHz/10kHz Resolution
  - 5x/6x/6.67x/8x/10x/12x/13.33x/16x/20x/24x Interpolation
  - Integrated Clock Multiplying PLL+VCO
- Highly Flexible and Configurable
  - 1, 2, or 4-Lane JESD204B Input Data Interface
    - Subclass-0 and Subclass-1 Compliant
    - Up to 10Gbps Per Lane
  - Reference Clock for System Synchronization
  - Multiple DAC Synchronization (Subclass-1)
  - SPI Interface for Device Configuration

### Applications

- Cellular Base-Station Transmitters
  - 2.5G/3G - GSM/TDMA/CDMA/UMTS
  - 4G LTE and WiMAX
- Multi-Standard and Multi-Band Transmitters
- Point-to-Point Microwave Links
- Wireless Backhaul

### Simplified Block Diagram

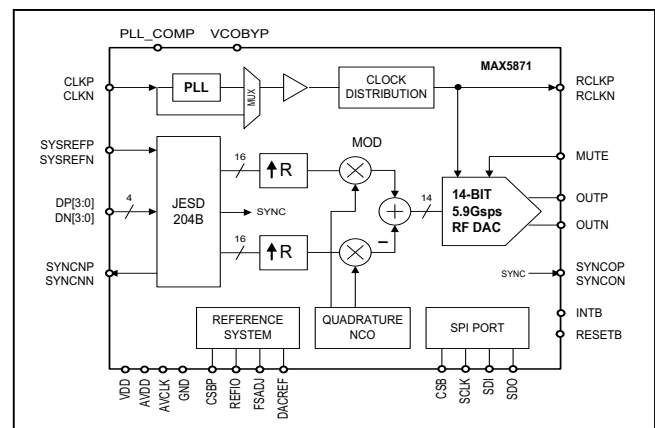

---

**TABLE OF CONTENTS**

---

General Description . . . . .	1
Benefits and Features . . . . .	1
Applications . . . . .	1
Simplified Block Diagram . . . . .	1
Absolute Maximum Ratings . . . . .	6
Package Thermal Characteristics . . . . .	6
Electrical Characteristics . . . . .	6
Typical Operating Characteristics . . . . .	13
Pin Configuration . . . . .	18
Pin Description . . . . .	19
Functional Diagram . . . . .	21
Detailed Description . . . . .	22
JESD204B Interface . . . . .	23
JESD204B Data Interface Features . . . . .	24
High-Speed Input Receiver (Rx) . . . . .	24
JESD204B Receiver Equalization . . . . .	26
Synchronization with SYSREF . . . . .	27
Link Layer (LINK) . . . . .	29
Lane Skew Requirement . . . . .	30
Mapping of Physical to Logical Channels . . . . .	30
Serial Control Interface . . . . .	31
Interrupt and Mute . . . . .	36
Digital Control Pins . . . . .	38
Frequency Planning . . . . .	38
Signal Bandwidth . . . . .	39
Complex Modulator and NCO . . . . .	39
Analog Interface . . . . .	41
Reference Interface . . . . .	41
Analog Output . . . . .	41
DAC Clock PLL . . . . .	42
VCO Band Select . . . . .	44
Lock Detect . . . . .	44
PLL External Components . . . . .	44
Interpolation Filters . . . . .	44

**TABLE OF CONTENTS (CONTINUED)**

Register Definition and Description . . . . .	52
Register Bank Name, Bytes, Type, Address and Description . . . . .	52
Global Configuration Registers Definition and Description . . . . .	55
DSP and DAC Configuration Registers Definition and Description . . . . .	58
Link Layer Configuration Registers Definition and Description . . . . .	67
SERDES Common Registers Definition and Description. . . . .	90
Applications Information. . . . .	95
Typical Configuration . . . . .	95
MAX5871 Flow Chart . . . . .	95
Power Up . . . . .	95
Chip Reset . . . . .	95
Clock Setup . . . . .	95
FIFO Reset. . . . .	96
Mode Setup . . . . .	97
Interrupt Mode Enables . . . . .	97
Start Data. . . . .	97
Clear and Check Statuses. . . . .	97
Unmute DAC . . . . .	97
JESD204B Rx Link and DSP Clocking. . . . .	98
Subclass-0 with Device Clock . . . . .	98
Subclass-0 without Device Clock . . . . .	99
Subclass-1 with Device Clock . . . . .	99
Subclass-1 without Device Clock. . . . .	99
MAX5871 Configuration . . . . .	100
MAX5871 Example Configuration Option-1. . . . .	100
JESD204B Subclass-1 SYSREF Signal Functionality . . . . .	103
Synchronous SYSREF Mode. . . . .	103
Asynchronous SYSREF Mode. . . . .	104
Applications Guidelines. . . . .	105

**TABLE OF CONTENTS (CONTINUED)**

Power Sequence . . . . .	105
Power Supply AVCLK . . . . .	105
Power-On RESETB and SPI Configuration . . . . .	105
Delay Time TD_DivRst Estimation . . . . .	105
Pin DACREF Consideration . . . . .	105
DAC PLL Consideration . . . . .	105
Pin SDO Consideration . . . . .	105
Clock Requirement . . . . .	105
NCO Frequency . . . . .	106
Latency . . . . .	106
Turn off JESD204B Transmitter . . . . .	106
PRBS Sequence . . . . .	106
DSP FIFO Reading . . . . .	106
DAC Output Impedance Model and Matching Network . . . . .	106
Thermal Considerations . . . . .	107
Ordering Information . . . . .	107
Package Information . . . . .	107
Revision History . . . . .	108

**LIST OF FIGURES**

Figure 1. Simplified Diagram of JESD204B Internal to MAX5871 . . . . .	23
Figure 2. JESD204B Rx Physical Layer Simplified Block Diagram . . . . .	24
Figure 3. VGA Gain Range . . . . .	25
Figure 4. Receiver Equalization Eye Diagram Before and After Lane Training (9.8304Gbps, 30in Nelco Trace) . . . . .	26
Figure 5. Channel Loss Curve (30in) . . . . .	26
Figure 6. SYSREF Usage for Sample Clock (DLCK/2) Generation and Synchronization . . . . .	27
Figure 7. SYSREF Usage for Sample Clock (From DACCLK) Generation and Synchronization . . . . .	28
Figure 8. Interface Timing for Subclass-0 (See JEDEC Standard No. 204B.01, Figure 11) . . . . .	28
Figure 9. JESD204B Receive Link Layer Block Diagram . . . . .	29
Figure 10. JESD204B Receive Lane Block Diagram . . . . .	29
Figure 11. Octet To Sample Conversion vs. Modes and Lanes . . . . .	30
Figure 12. Single SPI Write Transaction with MSB-First . . . . .	31
Figure 13. Single SPI Read Transaction with MSB-First . . . . .	32
Figure 14. Single SPI Write Transaction with LSB-First . . . . .	32

**LIST OF FIGURES (CONTINUED)**

Figure 15. Single SPI Read Transaction with LSB-First . . . . .	33
Figure 16. Burst SPI Write Transaction with MSB-First. . . . .	33
Figure 17. Burst SPI Read Transaction with MSB-First. . . . .	34
Figure 18. Burst SPI Write Transaction with LSB-First . . . . .	34
Figure 19. Burst SPI Read Transaction with LSB-First . . . . .	35
Figure 20. MAX5871 Interrupt Tree . . . . .	36
Figure 21. MAX5871 DAC Mute Generation . . . . .	38
Figure 22. Example of Multiband Transmission and Dominant Harmonic Locations . . . . .	38
Figure 23. Complex NCO and Modulator. . . . .	39
Figure 24. NCO Block Diagram . . . . .	40
Figure 25a. Reference Architecture, Internal Reference Configuration . . . . .	41
Figure 25b. Reference Architecture, External Reference Configuration. . . . .	41
Figure 26. Typical DAC Output Configuration . . . . .	42
Figure 27. Output Configuration for Low-Frequency Operation. . . . .	42
Figure 29. DAC Clock PLL External Components. . . . .	44
Figure 30. 5x Filter Baseband Frequency Response Normalized to DAC Output Update Rate. . . . .	49
Figure 31. 6x Filter Baseband Frequency Response Normalized to DAC Output Update Rate . . . . .	49
Figure 32. 6.67x Filter Baseband Frequency Response Normalized to DAC Output Update Rate . . . . .	50
Figure 34. 10x Filter Baseband Frequency Response Normalized to DAC Output Update Rate . . . . .	50
Figure 33. 8x Filter Baseband Frequency Response Normalized to DAC Output Update Rate. . . . .	50
Figure 35. 12x Filter Baseband Frequency Response Normalized to DAC Output Update Rate . . . . .	50
Figure 36. 13.33x Filter Baseband Frequency Response Normalized to DAC Output Update Rate . . . . .	51
Figure 38. 20x Filter Baseband Frequency Response Normalized to DAC Output Update Rate. . . . .	51
Figure 37. 16x Filter Baseband Frequency Response Normalized to DAC Output Update Rate . . . . .	51
Figure 39. 24x Filter Baseband Frequency Response Normalized to DAC Output Update Rate . . . . .	51
Figure 40. Rx Link and DSP Clocking. . . . .	98
Figure 41. Asynchronous SYSREF Mode with One-Shot Pulse . . . . .	104
Figure 42. Asynchronous SYSREF Mode with Continuous Pulses. . . . .	104

**LIST OF TABLES**

Table 1. JESD204B Receiver Power Dissipation. . . . .	23
Table 2. MAX5871 Status Register Bits. . . . .	36
Table 3. PLL Configuration Settings and Overall Multiplication Factor . . . . .	43
Table 4. Digital Filter Coefficients for 8x and 10x Interpolation Ratios . . . . .	45

**Absolute Maximum Ratings**

VDD2, AVCLK2, AVDD2, AVDD2PLL, VDD2PLL.....	-0.3V to +2.1V	PLL_COMP .....	-0.3V to (V <sub>AVDD2PLL</sub> + 0.3V, MAX 2.1V)
OUTP, OUTN .....	-0.3V to (V <sub>AVDD2</sub> + 0.5V)	VSSPLL, TDC, DACREF.....	(V <sub>GND</sub> - 0.3V) to (V <sub>GND</sub> + 0.3V)
MUTE, RESETB, CSB, SCLK, SDO, SDI, INTB,TDA .....	-0.3V to (V <sub>VDD2</sub> + 0.3V, MAX 2.1V)	VDD, AVDD, AVCLK, AVDD1PLL .....	-0.3V to +1.2V
SYSREFP, SYSREFN, SYNCIP, SYNCIN, SYNCOP, SYNCON, RCLKP, RCLKN .....	-0.3V to (V <sub>VDD2</sub> + 0.3V, MAX 2.1V)	REFIO, FSADJ, CSBP .....	-0.3V to (V <sub>AVDD2</sub> + 0.3V, MAX 2.1V)
DP0, DN0, DP1, DN1, DP2, DN2, DP3, DN3.....	-0.3V to (V <sub>VDD2</sub> + 0.3V, MAX 2.1V)	CLKP, CLKN.....	-0.3V to (V <sub>AVDD1PLL</sub> + 0.3V, MAX 1.2V)
JRES, CAPT, SYSREFEN .....	(V <sub>VSSPLL</sub> - 0.3V)	SDO, INTB Maximum Continuous Current .....	8mA
.....	to (V <sub>VDD2PLL</sub> + 0.3V, MAX 2.1V)	Continuous Power Dissipation (T <sub>A</sub> = +85°C).....	4.0W
VCOBYP.....	-0.3V to (V <sub>AVCLK2</sub> + 0.3V, MAX 2.1V)	Maximum Junction Temperature .....	+150°C
		Storage Temperature Range .....	-60°C to +150°C
		Junction Operating Temperature Range (T <sub>J</sub> )....	-40°C to +110°C
		Operating Temperature Range (T <sub>A</sub> ).....	-40°C to +85°C
		Soldering Temperature (reflow).....	+260°C

Stresses beyond those listed under "Absolute Maximum Ratings" may cause permanent damage to the device. These are stress ratings only, and functional operation of the device at these or any other conditions beyond those indicated in the operational sections of the specifications is not implied. Exposure to absolute maximum rating conditions for extended periods may affect device reliability.

**Package Thermal Characteristics (Note 1)**

FCCSP

Junction-to-Ambient Thermal Resistance (θ <sub>JA</sub> ) .....	16.2°C/W
Junction-to-Case Thermal Resistance (θ <sub>JC</sub> ).....	2.5°C/W

**Note 1:** Package thermal resistances were obtained using the method described in JEDEC specification JESD51-7, using a four-layer board. For detailed information on package thermal considerations, refer to [www.maximintegrated.com/thermal-tutorial](http://www.maximintegrated.com/thermal-tutorial).

**Electrical Characteristics**

(V<sub>DD</sub> = V<sub>AVCLK</sub> = V<sub>AVDD</sub> = V<sub>AVDD1PLL</sub> = 1V, V<sub>DD2</sub> = V<sub>AVCLK2</sub> = V<sub>AVDD2</sub> = V<sub>AVDD2PLL</sub> = V<sub>VDD2PLL</sub> = 1.8V, P<sub>CLK</sub> = +7dBm, f<sub>CLK</sub> = 983.04MHz, f<sub>DAC</sub> = 4915.2Msps, 6.67x interpolation, 4-lanes, 7372.8Mbps per lane, external reference at 1.20V and R<sub>SET</sub> = 1.3kΩ between FSADJ and DACREF, I<sub>OUTFS</sub> = 29.5385mA, output is 50Ω double-terminated and transformer coupled (see Figure 26), PLL ON. T<sub>A</sub> ≥ -40°C and T<sub>J</sub> ≤ +110°C (Note 2), unless otherwise noted. Typical values are at T<sub>J</sub> = +65.)

PARAMETER	SYMBOL	CONDITIONS	MIN	TYP	MAX	UNITS
<b>STATIC PERFORMANCE</b>						
Input Data Word Width	N			16		Bits
DAC Resolution				14		Bits
Differential Nonlinearity	DNL	Figure 27		±1.5		LSB
Integral Nonlinearity	INL	Figure 27		±3		LSB
Offset Voltage Error	OS			0.003		%FS
Full-Scale Output Current	I <sub>OUTFS</sub>		10		30	mA
Output Voltage Gain Error	GE <sub>FS</sub>	f <sub>OUT</sub> = DC, Figure 27		±3		%FS
Output Power	P <sub>OUT</sub>	f <sub>OUT</sub> = 100MHz		0		dBm
Maximum Output Compliance				V <sub>AVDD2</sub> + 0.4V		V
Minimum Output Compliance				V <sub>AVDD2</sub> - 0.4V		V
Output Resistance	R <sub>OUT</sub>	Differential DAC output resistance		50		Ω

Electrical Characteristics (continued)

(V<sub>DD</sub> = V<sub>AVCLK</sub> = V<sub>AVDD</sub> = V<sub>AVDD1PLL</sub> = 1V, V<sub>DD2</sub> = V<sub>AVCLK2</sub> = V<sub>AVDD2</sub> = V<sub>AVDD2PLL</sub> = V<sub>VDD2PLL</sub> = 1.8V, P<sub>CLK</sub> = +7dBm, f<sub>CLK</sub> = 983.04MHz, f<sub>DAC</sub> = 4915.2Msps, 6.67x interpolation, 4-lanes, 7372.8Mbps per lane, external reference at 1.20V and R<sub>SET</sub> = 1.3kΩ between FSADJ and DACREF, I<sub>OUTFS</sub> = 29.5385mA, output is 50Ω double-terminated and transformer coupled (see Figure 26), PLL ON. T<sub>A</sub> ≥ -40°C and T<sub>J</sub> ≤ +110°C (Note 2), unless otherwise noted. Typical values are at T<sub>J</sub> = +65.)

PARAMETER	SYMBOL	CONDITIONS		MIN	TYP	MAX	UNITS	
<b>DYNAMIC PERFORMANCE</b>								
Maximum DAC Sample Rate	f <sub>DAC</sub>	Smallest interpolation factor = 5x			3686.4		Msps	
		Smallest interpolation factor = 6x			4423.68			
		Smallest interpolation factor = 6.67x (Note 3)			4915.2			
		PLL ON, f <sub>CLK</sub> = 1474.56MHz, P <sub>CLK</sub> = -3dBm, smallest interpolation factor or greater = 8x, f <sub>SER_IN</sub> = 7372.8Mbps				5898.24		
Adjusted DAC Update Rate	AUR <sub>DAC</sub>	(Note 4)				737.28	Msps	
Maximum Input Sample Rate	f <sub>S_IN</sub>	For the complex I/Q data set			737.28		MHz	
In-Band SFDR (Notes 5 and 6)	SFDR	CW tone at 1842.5MHz	-15dBFS		68		dBc	
			-19dBFS		82		dBFS	
			-33dBFS		76			
HD2, HD3, f <sub>DAC</sub> /2-f <sub>OUT</sub> . Measured in 1st Nyquist Zone		CW tone at 1842.5MHz	-3dBFS		-71		dBc	
			1.4MHz LTE carrier at 2140MHz; Measured in a 1.4MHz bandwidth around the harmonic/spur location	-18dBFS		-65		dBc
				-33dBFS		-87		dBFS
Intermodulation Distortion (Note 6)	IMD	Two-tone signal, f <sub>1</sub> = 1842MHz and f <sub>2</sub> = 1843MHz	Average total power -15dBFS		-74		dBc	
			Average total power -33dBFS		-80		dBFS	
3 <sup>rd</sup> Order Intermodulation Distortion (Difference Products Only)	IM3	Two-Carrier GSM (GMSK) signal, 600kHz spacing, -13dBFS per carrier at DAC input, f <sub>1</sub> = 1842.2MHz, f <sub>2</sub> = 1842.8MHz, Both carrier and intermodulation products measured with RBW = 30kHz (Note 7)		-65	-74		dBc	
Four-Carrier ACLR for WCDMA, Test Model 1	ACLR	Each a single 5MHz UMTS carrier, f <sub>1</sub> = 2131MHz, f <sub>2</sub> = 2137MHz, f <sub>3</sub> = 2143MHz, f <sub>4</sub> = 2149MHz, -15dBFS average total power at DAC input			70		dBc	

**Electrical Characteristics (continued)**

(V<sub>DD</sub> = V<sub>AVCLK</sub> = V<sub>AVDD</sub> = V<sub>AVDD1PLL</sub> = 1V, V<sub>DD2</sub> = V<sub>AVCLK2</sub> = V<sub>AVDD2</sub> = V<sub>AVDD2PLL</sub> = V<sub>VDD2PLL</sub> = 1.8V, P<sub>CLK</sub> = +7dBm, f<sub>CLK</sub> = 983.04MHz, f<sub>DAC</sub> = 4915.2Msps, 6.67x interpolation, 4-lanes, 7372.8Mbps per lane, external reference at 1.20V and R<sub>SET</sub> = 1.3kΩ between FSADJ and DACREF, I<sub>OUTFS</sub> = 29.5385mA, output is 50Ω double-terminated and transformer coupled (see Figure 26), PLL ON. T<sub>A</sub> ≥ -40°C and T<sub>J</sub> ≤ +110°C (Note 2), unless otherwise noted. Typical values are at T<sub>J</sub> = +65.)

PARAMETER	SYMBOL	CONDITIONS	MIN	TYP	MAX	UNITS
Output Power (CW)		0dBFS CW tone at DAC input, f <sub>OUT</sub> = 2140MHz		-1.6		dBm
		Excludes loss from cables and matching network at DAC output (Note 8)				
		Excludes loss from cables and matching network at DAC output, includes sin(x)/x roll-off		-4.5		
Noise Density	ND	CW tone at 1842.5MHz, -15dBFS, measured at 10MHz offset from carrier in 200kHz bandwidth		-160		dBm/Hz
Output Settling Time for Full-Scale Input Step (Note 9)		To -0.024% of output full-scale, 5x interpolation, f <sub>DAC</sub> = 3686.4Msps		20		ns
Output Bandwidth		f <sub>DAC</sub> = 5898.24Msps, -1dB bandwidth, Excludes loss from cables and matching network at DAC output (Note 8)		2600		MHz
<b>DAC RESPONSE CHARACTERISTIC</b>						
Gain Flatness In-Band (Note 6)		Over 80MHz bandwidth, f <sub>DAC</sub> = 4915.2Msps, includes 0.2dB sinc(x) roll-off		0.6		dB
		Over 300MHz bandwidth, f <sub>DAC</sub> = 4915.2Msps, includes 0.8dB sinc(x) roll-off		2.2		
<b>INTERPOLATION FILTERS</b>						
Interpolation Rates (Note 3)	R			5x, 6x, 6.67x, 8x, 10x, 12x, 13.33x, 16x, 20x, 24x		
Passband Width		Ripple < 0.01dB		0.407 x f <sub>S_IN</sub>		
Stopband Rejection		0.593 x f <sub>S_IN</sub>		90		dB



## Electrical Characteristics (continued)

( $V_{DD} = V_{AVCLK} = V_{AVDD} = V_{AVDD1PLL} = 1V$ ,  $V_{DD2} = V_{AVCLK2} = V_{AVDD2} = V_{AVDD2PLL} = V_{VDD2PLL} = 1.8V$ ,  $P_{CLK} = +7dBm$ ,  $f_{CLK} = 983.04MHz$ ,  $f_{DAC} = 4915.2Msps$ , 6.67x interpolation, 4-lanes, 7372.8Mbps per lane, external reference at 1.20V and  $R_{SET} = 1.3k\Omega$  between FSADJ and DACREF,  $I_{OUTFS} = 29.5385mA$ , output is 50 $\Omega$  double-terminated and transformer coupled (see Figure 26), PLL ON.  $T_A \geq -40^\circ C$  and  $T_J \leq +110^\circ C$  (Note 2), unless otherwise noted. Typical values are at  $T_J = +65.$ )

PARAMETER	SYMBOL	CONDITIONS	MIN	TYP	MAX	UNITS
Data Latency (Excluding JESD204B Latency)		5x interpolation		371		DAC Update Cycles
		6x interpolation		403		
		6.67x interpolation (Note 3)		455		
		8x interpolation		438		
		10x interpolation		662		
		12x interpolation		749		
		13.33x interpolation (Note 3)		1260		
		16x interpolation		689		
		20x interpolation		923		
		24x interpolation		1105		
<b>NCO</b>						
Maximum Frequency				$f_{DAC}/2$		Hz
Frequency Control Word Resolution				33		Bits
SNR		(Note 10)		85.5		dB
SFDR		(Note 10)		90		dBc
<b>REFERENCE</b>						
Reference Input Range			1.10		1.30	V
Reference Output Voltage	$V_{REFIO}$	Internal reference	1.10	1.20	1.30	V
Reference Input Resistance	$R_{REFIO}$			10		k $\Omega$
Reference Voltage Drift				$\pm 110$		ppm/ $^\circ C$
<b>CMOS LOGIC INPUTS/OUTPUTS (SCLK, CSB, MUTE, RESETB, SDI, SDO, INTB)</b>						
Input High Voltage	$V_{IH}$		0.7 x $V_{DD2}$			V
Input Low Voltage	$V_{IL}$		0.3 x $V_{DD2}$			V
Input Current	$I_{IN}$	Excluding RESETB	-1	$\pm 0.1$	+1	$\mu A$
RESETB Input Current	$I_{INRB}$		-1		55	$\mu A$
Input Capacitance	$C_{IN}$			3		pF
Output High Voltage	$V_{OH}$	$I_{LOAD} = 200\mu A$ , INTB has a 1k $\Omega$ external pullup resistor to $V_{DD2}$	0.8 x $V_{DD2}$			V
Output Low Voltage	$V_{OL}$	$I_{SINK} = 200\mu A$ , INTB has a 1k $\Omega$ external pullup resistor to $V_{DD2}$	0.2 x $V_{DD2}$			V
Output Leakage Current		Three-state, SDO pin	-4	$\pm 2.5$	+4	$\mu A$

## Electrical Characteristics (continued)

( $V_{DD} = V_{AVCLK} = V_{AVDD} = V_{AVDD1PLL} = 1V$ ,  $V_{DD2} = V_{AVCLK2} = V_{AVDD2} = V_{AVDD2PLL} = V_{VDD2PLL} = 1.8V$ ,  $P_{CLK} = +7dBm$ ,  $f_{CLK} = 983.04MHz$ ,  $f_{DAC} = 4915.2Msps$ , 6.67x interpolation, 4-lanes, 7372.8Mbps per lane, external reference at 1.20V and  $R_{SET} = 1.3k\Omega$  between FSADJ and DACREF,  $I_{OUTFS} = 29.5385mA$ , output is 50 $\Omega$  double-terminated and transformer coupled (see Figure 26), PLL ON.  $T_A \geq -40^\circ C$  and  $T_J \leq +110^\circ C$  (Note 2), unless otherwise noted. Typical values are at  $T_J = +65$ .)

PARAMETER	SYMBOL	CONDITIONS	MIN	TYP	MAX	UNITS
<b>JESD204B INPUTS (DP3–DP0, DN3–DN0)</b>						
Differential Input Return Loss	$R_{LDIFF}$			8		dB
Common-Mode Input Return Loss	$R_{LCM}$			6		dB
Receiver Differential Impedance	$Z_{RDIFF}$	At DC	80		120	$\Omega$
Minimum Differential Input Voltage	$V_{min\_IN}$			110		mV <sub>P-P</sub>
Maximum Differential Input Voltage	$V_{max\_IN}$			1050		mV <sub>P-P</sub>
Discrete Serial Data Rate per Lane	$f_{SER\_IN}$	Also supports ½ and ¼ fractional data rates		9830.4		Mbps
		Also supports ½ fractional data rates		7372.8		
				6144.0		
<b>LVDS LOGIC INPUT/OUTPUT (SYNCNP, SYNCNN, SYSREFP, SYSREFN, SYNCIP, SYNCIN, SYNCOP, SYNCON, RCLKP, RCLKN)</b>						
Differential Input Logic High	$V_{IH}$		100			mV
Differential Input Logic Low	$V_{IL}$				-100	mV
Input Common-Mode Voltage	$V_{ICM}$		0.675		1.375	V
Differential Input Resistance	$R_{IN}$		87.5	100	132.5	$\Omega$
Differential Input Capacitance	$C_{INLVDS}$			1		pF
Differential Output Logic High	$V_{OH}$	$R_{LOAD} = 100\Omega$ differential	250		450	mV
Differential Output Logic Low	$V_{OL}$	$R_{LOAD} = 100\Omega$ differential	-450		-250	mV
Output Common-Mode Voltage	$V_{OCM}$		1.125	1.25	1.375	V
Output Maximum Frequency	$f_{RCLK}$	$R_{LOAD} = 100\Omega$ differential, $C_{LOAD} = 8pF$		737.28		MHz
<b>CLOCK INPUT (CLKP, CLKN)</b>						
Power Level at Differential CLKP/CLKN Clock Input (Note 11)	$P_{CLK}$	Sine-wave input, PLL OFF, $f_{CLK} = 4915.2MHz$		> 0		dBm (50 $\Omega$ )
		Sine-wave input, PLL OFF, $f_{CLK} = 5898.24MHz$		> 5		
		Sine-wave input, PLL ON		> -3		
Common-Mode Voltage	$V_{COM}$	AC-coupled, internally biased		0.5		V
Differential Input Resistance	$R_{CLK}$			100		$\Omega$

## Electrical Characteristics (continued)

( $V_{DD} = V_{AVCLK} = V_{AVDD} = V_{AVDD1PLL} = 1V$ ,  $V_{DD2} = V_{AVCLK2} = V_{AVDD2} = V_{AVDD2PLL} = V_{VDD2PLL} = 1.8V$ ,  $P_{CLK} = +7dBm$ ,  $f_{CLK} = 983.04MHz$ ,  $f_{DAC} = 4915.2MSPS$ , 6.67x interpolation, 4-lanes, 7372.8Mbps per lane, external reference at 1.20V and  $R_{SET} = 1.3k\Omega$  between FSADJ and DACREF,  $I_{OUTFS} = 29.5385mA$ , output is 50 $\Omega$  double-terminated and transformer coupled (see Figure 26), PLL ON.  $T_A \geq -40^\circ C$  and  $T_J \leq +110^\circ C$  (Note 2), unless otherwise noted. Typical values are at  $T_J = +65^\circ C$ .)

PARAMETER	SYMBOL	CONDITIONS	MIN	TYP	MAX	UNITS
<b>INTERNAL DAC CLOCK PLL</b>						
Internal DAC Clock PLL Frequency Range	$f_{PLL}$	Low-band VCO minimum frequency			4423.68	MHz
		Low-band VCO maximum frequency	4915.2			
		High-band VCO minimum frequency			5898.24	
		High-band VCO maximum frequency	6144.0			
PLL Input Frequencies	$f_{CLK}$			$f_{PLL}/MLT$		MHz
Minimum PLL Input Frequency Multiplier	$MLT_{min}$	(Note 12)		2		Hz/Hz
Maximum PLL Input Frequency Multiplier	$MLT_{max}$	(Note 12)		60		Hz/Hz
Phase Noise at 6MHz Offset		$f_{DAC} = 4915.2MSPS$ , measured at PLL output, does not include DAC core phase noise		-142		dBc/Hz
Cycle-to-Cycle Jitter		$f_{DAC} = 4915.2MSPS$ , measured at PLL output, does not include DAC core jitter		245		fs
<b>RESET TIMING</b>						
RESET to Ready Delay	$t_{RRDY}$			350000		$f_{CLK}$ Cycles
<b>SERIAL PORT INTERFACE TIMING (Note 7)</b>						
SCLK Frequency	$f_{SCLK}$	$1/t_{SCLK}$			25	MHz
SCLK to CSB Setup Time	$t_{CSS}$			10		ns
SCLK to CSB Hold Time	$t_{CSH}$			0		ns
SDI to SCLK Hold Time	$t_{SDH}$	Data-write		0		ns
SDI to SCLK Setup Time	$t_{SDS}$	Data-write		5		ns
Minimum SCLK to SDO Data Delay	$t_{SDD\_MIN}$	Data-read, 10pF load from SDO to Ground		1.5		ns
		Data-read, 100pF load from SDO to Ground		3.5		ns
Maximum SCLK to SDO Data Delay	$t_{SDD\_MAX}$	Data-read, 10pF load from SDO to Ground		8		ns
		Data-read, 100pF load from SDO to Ground		11		
<b>POWER SUPPLY</b>						
1.0V Supply Voltage Range	$V_{DD}$ , $V_{AVDD}$ , $V_{AVDD1PLL}$		0.95	1.0	1.05	V
		$V_{AVCLK}$				
		$f_{DAC}$ sample rate $\leq 4.9152GSPS$	0.95	1.0	1.05	
		$f_{DAC}$ sample rate $> 4.9152GSPS$ and $\leq 5.89824GSPS$	1.00	1.02	1.05	

## Electrical Characteristics (continued)

( $V_{DD} = V_{AVCLK} = V_{AVDD} = V_{AVDD1PLL} = 1V$ ,  $V_{DD2} = V_{AVCLK2} = V_{AVDD2} = V_{AVDD2PLL} = V_{VDD2PLL} = 1.8V$ ,  $P_{CLK} = +7dBm$ ,  $f_{CLK} = 983.04MHz$ ,  $f_{DAC} = 4915.2MSPS$ , 6.67x interpolation, 4-lanes, 7372.8Mbps per lane, external reference at 1.20V and  $R_{SET} = 1.3k\Omega$  between FSADJ and DACREF,  $I_{OUTFS} = 29.5385mA$ , output is 50 $\Omega$  double-terminated and transformer coupled (see Figure 26), PLL ON.  $T_A \geq -40^\circ C$  and  $T_J \leq +110^\circ C$  (Note 2), unless otherwise noted. Typical values are at  $T_J = +65^\circ C$ .)

PARAMETER	SYMBOL	CONDITIONS	MIN	TYP	MAX	UNITS
1.8V Supply Voltage Range	$V_{DD2}$ , $V_{AVCLK2}$ , $V_{AVDD2}$ , $V_{AVDD2PLL}$ , $V_{DD2PLL}$		1.71	1.8	1.89	V
1.0V Digital Supply Current	$I_{VDD}$	$f_{DAC} = 4915.2MSPS$ , $f_{OUT} = 1842.5MHz$ , 6.67x interpolation, PLL ON, JESD204B Lanes = 4		530	940	mA
1.8V Digital Supply Current	$I_{VDD2}$			390	445	mA
1.0V Clock Supply Current	$I_{AVCLK}$			360	510	mA
1.8V Clock Supply Current	$I_{AVCLK2}$			57	70	mA
1.0V Analog Supply Current	$I_{AVDD}$			237	345	mA
1.8V Analog Supply Current	$I_{AVDD2}$			248	292	mA
1.0V Clock PLL Supply Current	$I_{AVDD1PLL}$			8	15	mA
1.8V Clock PLL Supply Current	$I_{AVDD2PLL}$			28	34	mA
1.8V JESD204B PLL Supply Current	$I_{VDD2PLL}$			30	36	mA
Total Power Dissipation	$P_{TOTAL}$				2490	3389

**Note 2:** All specifications are guaranteed via test at  $T_J = +60^\circ C$  and  $T_J = +115^\circ C$  to an accuracy of  $\pm 10^\circ C$ . Specifications at  $T_J < +60^\circ C$  are guaranteed by design and characterization. Timing specifications are guaranteed by design and characterization.

**Note 3:** The 6.67x and 13.33x interpolation rates are precisely  $(20 \div 3)x$  and  $(40 \div 3)x$ , respectively.

**Note 4:** Adjusted DAC update rate is defined as the maximum DAC update rate divided by the smallest interpolating factor. Note this is a mathematically derived specification.

**Note 5:** SFDR is the minimum ratio in carrier power to the power measured in specified bandwidth (RBW) that is offset from the carrier and swept over a particular band. The carrier power is measured with a 30kHz bandwidth. The spur RBW is 30kHz or 100kHz depending on the frequency distance from the center of the carrier. In the case of multicarrier SFDR, the frequency distance/offset is measured from the center of either edge carrier. The spur RBW is 30kHz for frequency offsets from 0 to 1.8MHz and 100kHz for frequency offsets greater than 1.8MHz.

**Note 6:** In-band is considered to be 1710MHz to 2170MHz, inclusive.

**Note 7:** Specification guaranteed by design and characterization, and functionally tested during production.

**Note 8:** Excludes  $\sin(x)/x$  roll-off.

**Note 9:** Settling time is dominated by the interpolation filter step response.

**Note 10:** Typical values specified based on worst-case simulation with margin.

**Note 11:** Input power is referenced to a 50 $\Omega$  load.

**Note 12:** DAC PLL reference input frequency multiplier, MLT, is defined by the ratio of the PLL feedback divide value, M, and the input reference divide value, N.  $MLT = M \div N$

where M can be {16, 20, 24, 28, 32, 36, 40, 44, 48, 52, 56, or 60} and where N can be {1, 2, 4, or 8}.

Typical Operating Characteristics

( $V_{DD} = V_{AVCLK} = V_{AVDD} = V_{AVDD1PLL} = 1V$ ,  $V_{DD2} = V_{AVCLK2} = V_{AVDD2}$ ,  $V_{AVDD2PLL} = V_{DD2PLL} = 1.8V$ ,  $P_{CLK} = 0dBm$ , signal power is referred to the DAC core input,  $f_{CLK} = 983.04MHz$ ,  $f_{DAC} = 4915.2Msps$ , 6.67x interpolation, 4 lanes, 7.3728Gbps per lane. External reference at 1.2V and  $R_{SET} = 1.3k\Omega$ ,  $I_{OUTFS} = 29.5385mA$ , output is 50Ω double-terminated and transformer coupled (see Figure 26), and  $T_A = +25^\circ C$ , unless otherwise noted.) (Note 6)

SINGLE-CARRIER GSM (GMSK) NARROW-BAND SPECTRUM  
( $f_{OUT} = 1.82GHz$ ,  $f_{CLK} = 1.47456GHz$ ,  
INPUT AMPLITUDE = -15dBFS,  $T_A = +25^\circ C$ )

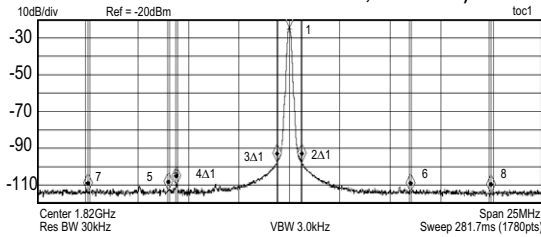

MKR#	MEASUREMENT TYPE	FREQUENCY	BAND POWER	POWER INTEGRATION BANDWIDTH	UNITS
1	Absolute	1.82GHz	-24.48	30kHz	dBm
2	Delta to Mkr#1	+600kHz	-73.36	30kHz	dBc
3	Delta to Mkr#1	-600kHz	-73.31	30kHz	dBc
4	Delta to Mkr#1	-5.598MHz	-80.5	100kHz	dBc
5	Absolute	1.814GHz	-157.84	100kHz	dBm/Hz
6	Absolute	1.826GHz	-158.57	100kHz	dBm/Hz
7	Absolute	1.810GHz	-158.56	200kHz	dBm/Hz
8	Absolute	1.830GHz	-159.48	200kHz	dBm/Hz

SINGLE-CARRIER GSM (GMSK) NARROW-BAND SPECTRUM  
( $f_{OUT} = 1.82GHz$ ,  $f_{CLK} = 1.47456GHz$ ,  
INPUT AMPLITUDE = -15dBFS,  $T_J = 110^\circ C$ )

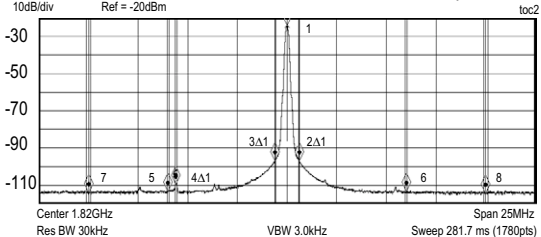

MKR#	MEASUREMENT TYPE	FREQUENCY	BAND POWER	POWER INTEGRATION BANDWIDTH	UNITS
1	Absolute	1.82GHz	-24.27	30kHz	dBm
2	Delta to Mkr#1	+600kHz	-72.89	30kHz	dBc
3	Delta to Mkr#1	-600kHz	-72.89	30kHz	dBc
4	Delta to Mkr#1	-5.598MHz	-80.22	100kHz	dBc
5	Absolute	1.814GHz	-158.29	100kHz	dBm/Hz
6	Absolute	1.826GHz	-158.44	100kHz	dBm/Hz
7	Absolute	1.810GHz	-158.94	200kHz	dBm/Hz
8	Absolute	1.830GHz	-159.48	200kHz	dBm/Hz

SINGLE-CARRIER GSM (GMSK) NARROW-BAND SPECTRUM  
( $f_{OUT} = 1.82GHz$ ,  $f_{CLK} = 1.47456GHz$ , 8x INTERPOLATION,  
INPUT AMPLITUDE = -15dBFS,  $T_J = +110^\circ C$ )

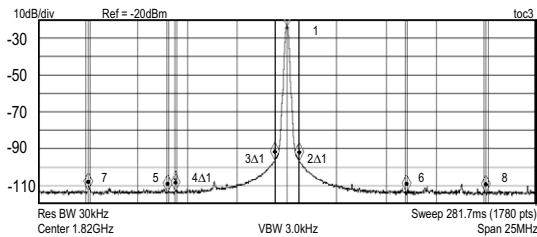

MKR#	MEASUREMENT TYPE	FREQUENCY	BAND POWER	POWER INTEGRATION BANDWIDTH	UNITS
1	Absolute	1.82GHz	-23.85	30kHz	dBm
2	Delta to Mkr#1	+600kHz	-72.85	30kHz	dBc
3	Delta to Mkr#1	-600kHz	-72.69	30kHz	dBc
4	Delta to Mkr#1	-5.598MHz	-84.32	100kHz	dBc
5	Absolute	1.814GHz	-158.81	100kHz	dBm/Hz
6	Absolute	1.826GHz	-158.56	100kHz	dBm/Hz
7	Absolute	1.810GHz	-157.62	200kHz	dBm/Hz
8	Absolute	1.830GHz	-159.48	200kHz	dBm/Hz

Typical Operating Characteristics (continued)

( $V_{DD} = V_{AVCLK} = V_{AVDD} = V_{AVDD1PLL} = 1V$ ,  $V_{DD2} = V_{AVCLK2} = V_{AVDD2}$ ,  $V_{AVDD2PLL} = V_{DD2PLL} = 1.8V$ ,  $P_{CLK} = 0dBm$ , signal power is referred to the DAC core input,  $f_{CLK} = 983.04MHz$ ,  $f_{DAC} = 4915.2MSPS$ , 6.67x interpolation, 4 lanes, 7.3728Gbps per lane. External reference at 1.2V and  $R_{SET} = 1.3k\Omega$ ,  $I_{OUTFS} = 29.5385mA$ , output is 50Ω double-terminated and transformer coupled (see Figure 26), and  $T_A = +25^\circ C$ , unless otherwise noted.) (Note 6)

SIX-CARRIER GSM ( $f_{OUT} = 1.8425GHz$ ) and 4-CARRIER WCDMA ( $f_{OUT} = 2.14GHz$ ), WIDE-BAND SPECTRUM (INPUT AMPLITUDE = -1dBFS)

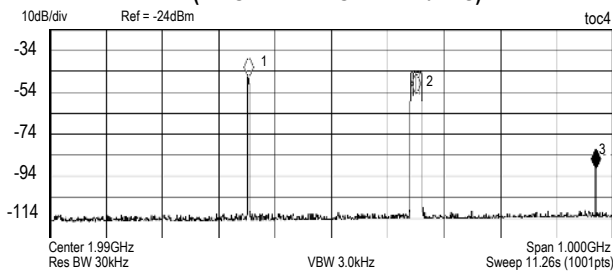

MKR#	FREQUENCY	POWER
1	1.841GHz	-47.13dBm
2	2.140GHz	-54.87dBm
3	2.4576GHz	-90.56dBm

SIX-CARRIER GSM ( $f_{OUT} = 1.8425GHz$ ) and 4-CARRIER WCDMA ( $f_{OUT} = 2.14GHz$ ), NARROW-BAND GSM SPECTRUM (INPUT AMPLITUDE = -1dBFS)

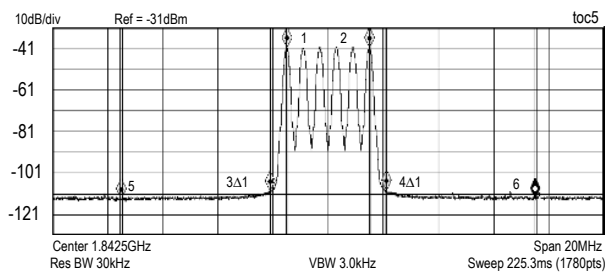

MKR#	MEASUREMENT TYPE	FREQUENCY	POWER	POWER INTEGRATION BANDWIDTH	UNITS
1	Absolute	1.841GHz	-41.17	30kHz	dBm
2	Absolute	1.844GHz	-40.98	30kHz	dBm
3	Delta to Mkr#1	-600kHz	-68.83	30kHz	dBc
4	Delta to Mkr#1	+3.600MHz	-68.38	30kHz	dBc
5	Absolute	1.835GHz	-158.24	100kHz	dBm/Hz
6	Absolute	1.850GHz	-158.00	100kHz	dBm/Hz

SIX-CARRIER GSM ( $f_{OUT} = 1.8425GHz$ ) and 4-CARRIER WCDMA ( $f_{OUT} = 2.14GHz$ ), NARROW-BAND WCDMA SPECTRUM (INPUT AMPLITUDE = -1dBFS)

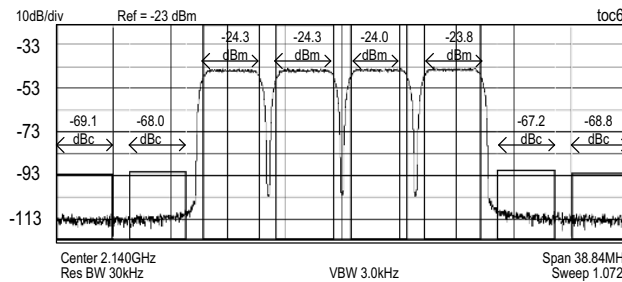

Typical Operating Characteristics (continued)

( $V_{DD} = V_{AVCLK} = V_{AVDD} = V_{AVDD1PLL} = 1V$ ,  $V_{DD2} = V_{AVCLK2} = V_{AVDD2}$ ,  $V_{AVDD2PLL} = V_{DD2PLL} = 1.8V$ ,  $P_{CLK} = 0dBm$ , signal power is referred to the DAC core input,  $f_{CLK} = 983.04MHz$ ,  $f_{DAC} = 4915.2MSPS$ , 6.67x interpolation, 4 lanes, 7.3728Gbps per lane. External reference at 1.2V and  $R_{SET} = 1.3k\Omega$ ,  $I_{OUTFS} = 29.5385mA$ , output is 50Ω double-terminated and transformer coupled (see Figure 26), and  $T_A = +25^\circ C$ , unless otherwise noted.) (Note 6)

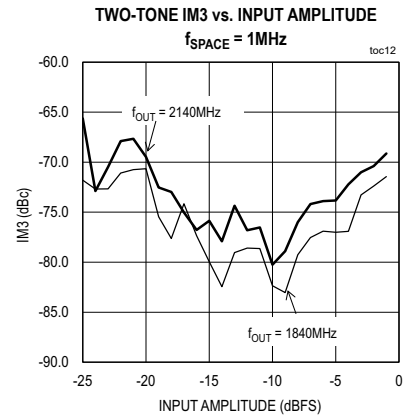
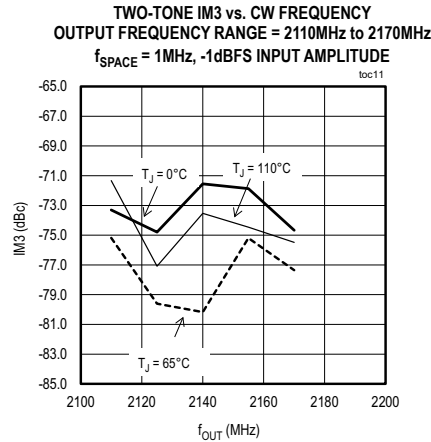
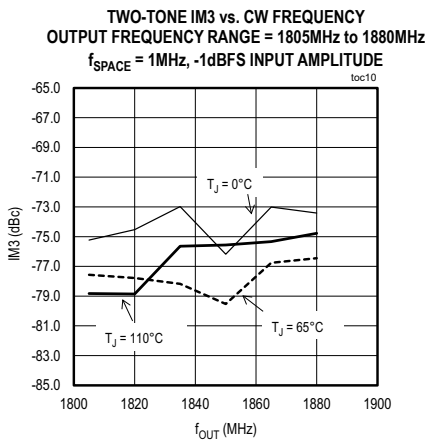
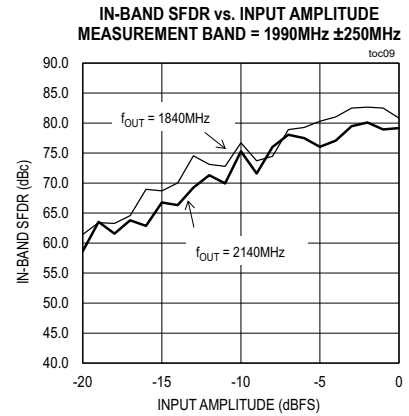
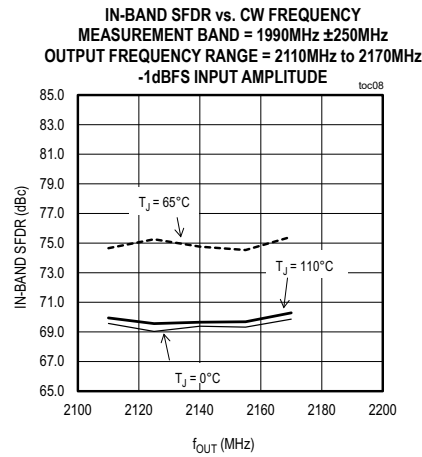
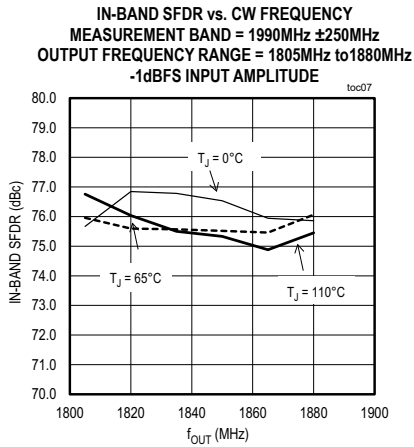

Typical Operating Characteristics (continued)

( $V_{DD} = V_{AVCLK} = V_{AVDD} = V_{AVDD1PLL} = 1V$ ,  $V_{DD2} = V_{AVCLK2} = V_{AVDD2}$ ,  $V_{AVDD2PLL} = V_{DD2PLL} = 1.8V$ ,  $P_{CLK} = 0dBm$ , signal power is referred to the DAC core input,  $f_{CLK} = 983.04MHz$ ,  $f_{DAC} = 4915.2MSPS$ , 6.67x interpolation, 4 lanes, 7.3728Gbps per lane. External reference at 1.2V and  $R_{SET} = 1.3k\Omega$ ,  $I_{OUTFS} = 29.5385mA$ , output is 50Ω double-terminated and transformer coupled (see Figure 26), and  $T_A = +25^\circ C$ , unless otherwise noted.) (Note 6)

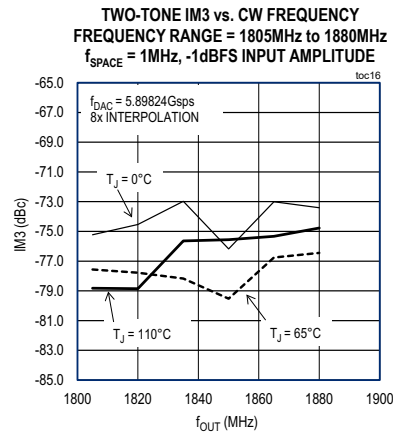
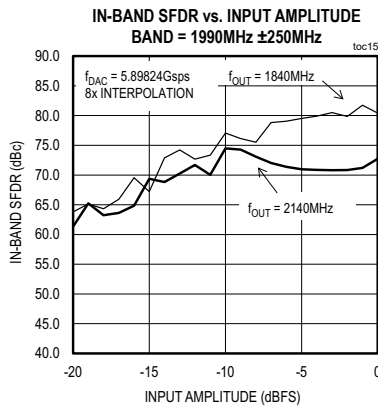
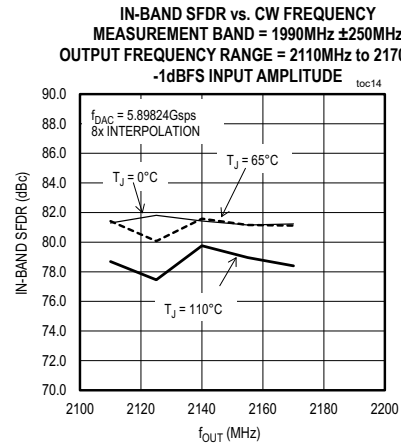
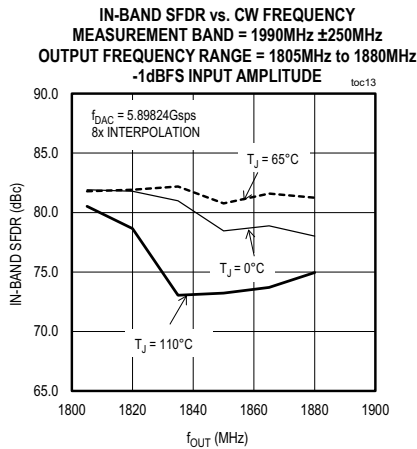



Typical Operating Characteristics (continued)

( $V_{DD} = V_{AVCLK} = V_{AVDD} = V_{AVDD1PLL} = 1V$ ,  $V_{DD2} = V_{AVCLK2} = V_{AVDD2}$ ,  $V_{AVDD2PLL} = V_{DD2PLL} = 1.8V$ ,  $P_{CLK} = 0dBm$ , signal power is referred to the DAC core input,  $f_{CLK} = 983.04MHz$ ,  $f_{DAC} = 4915.2MSPS$ , 6.67x interpolation, 4 lanes, 7.3728Gbps per lane. External reference at 1.2V and  $R_{SET} = 1.3k\Omega$ ,  $I_{OUTFS} = 29.5385mA$ , output is 50Ω double-terminated and transformer coupled (see Figure 26), and  $T_A = +25^\circ C$ , unless otherwise noted.) (Note 6)

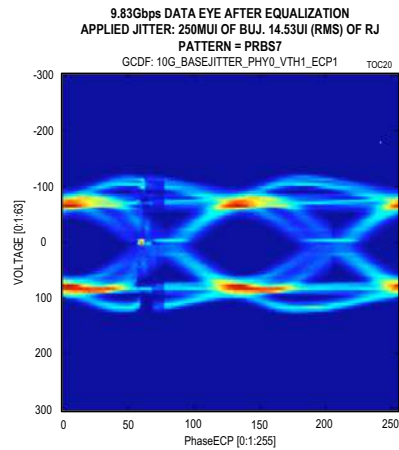
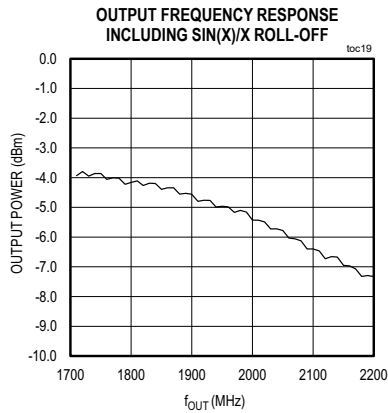
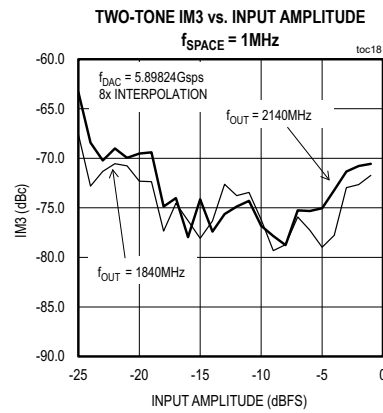
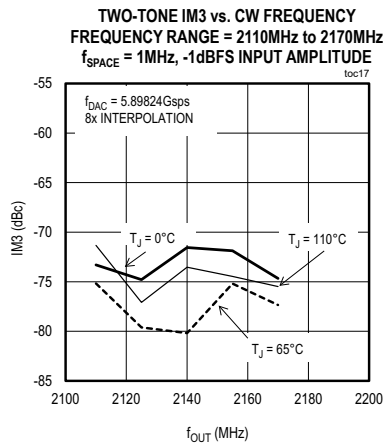

Pin Configuration

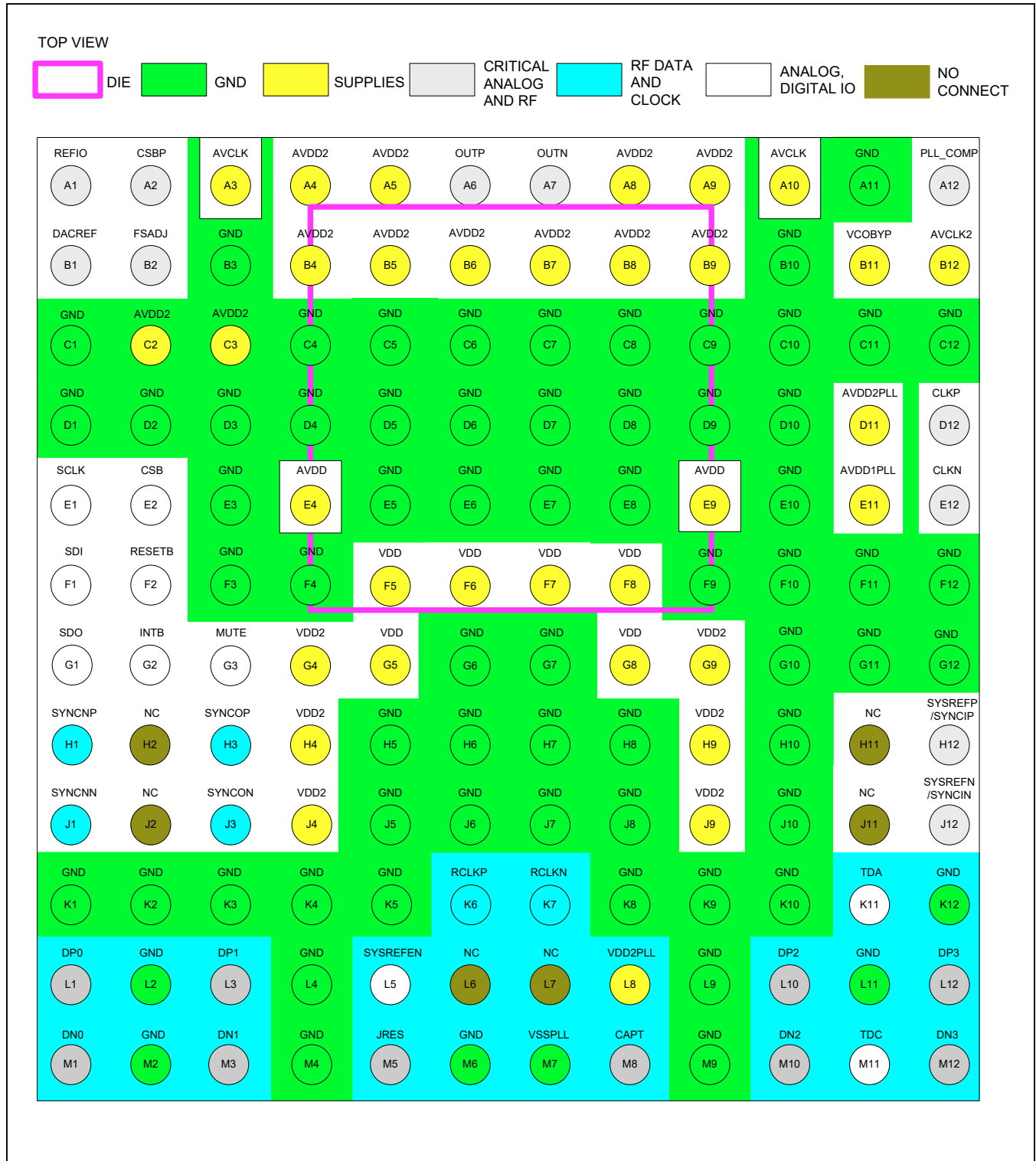

## Pin Description

PIN	NAME	FUNCTION
A1	REFIO	Reference Voltage Input/Output. REFIO outputs an internal 1.2V bandgap reference voltage. REFIO has a 10k $\Omega$ series resistance and can be driven using an external 1.2V reference voltage. Connect a 1 $\mu$ F capacitor between REFIO and DACREF.
A2	CSBP	DAC current source bypass. Connect 1.0 $\mu$ F capacitor between CSBP and DACREF.
B1	DACREF	Internal DAC Reference Ground Used for DAC Current Source Bypass Ground. Do not connect to board ground (GND).
B2	FSADJ	Analog Input for DAC Full-Scale Output Current Adjustment. A resistor from FSADJ to DACREF sets the full-scale output current of the DAC. To obtain a 29.5385mA full-scale output current using the internal reference voltage, connect a 1.3k $\Omega$ resistor between FSADJ and DACREF ground.
A4, A5, A8, A9, B4-B9, C2, C3	AVDD2	Analog 1.8V Supply Input
A6	OUTP	Positive Terminal of Differential DAC Output
A7	OUTN	Negative Terminal of Differential DAC Output
A11, B3, B10, C1, C4-C12, D1-D10, E3, E5-E8, E10, F3-F4, F9- F12, G6-G7, G10-G12, H5-H8, H10, J5-J8, J10, K1-K5, K8- K10, K12, L2, L4, L9, L11, M2, M4, M6, M9	GND	Ground
A12	PLL_COMP	Analog I/O for DAC PLL Loop Filter Connection
D11	AVDD2PLL	1.8V DAC Clock PLL Supply
E11	AVDD1PLL	1.0V DAC Clock PLL Supply
B12	AVCLK2	1.8V Supply Input for Clock
D12	CLKP	Clock Positive Input. Multipurpose pin that generates following internal clocks based on use case: 1) PLL use cases a) PLL OFF (Bypassed): Clock for RF DAC core (DACCLK) b) PLL ON (Enabled): Reference clock for DAC PLL which in turn generates the DACCLK 2) Device clock (DCLK) for JESD204B interface when frequency is $\leq$ 1474.56MHz (twice the maximum input sample rate of 737.28MHz) An internal 100 $\Omega$ termination resistor connects CLKP to CLKN.
E12	CLKN	Clock Negative Input
B11	VCOBYP	Pin for VCO Loop Filter
A3, A10	AVCLK	1.0V Supply Input for Clock
E4, E9	AVDD	Analog 1.0V Supply Input

## Pin Description (continued)

PIN	NAME	FUNCTION
F5-F8, G5, G8	VDD	1.0V Supply Input for Digital Core
E1	SCLK	Digital CMOS Input for Serial Port Interface Clock
E2	CSB	Digital CMOS Input for Serial Port Interface Chip Selection Bar. MAX5871 is selected when CSB = low.
F1	SDI	Digital CMOS Input for Serial Port Interface Data Input in 4-Wire SPI Interface Mode. Serial port data is latched on the rising edge of SCLK. Digital CMOS Input/Output for Serial Port Interface data Input and Output in 3-wire SPI interface mode. Equivalent to SDIO pin in a typical 3-wire SPI interface mode. Serial port data is latched on the rising edge of SCLK.
G1	SDO	Digital CMOS Output for Serial Port Interface Data Output. Serial port data is clocked out from MAX5871 on the falling edge of SCLK.
G2	INTB	Digital CMOS Output for Interrupt, open-drain output. Needs external pullup resistor, 1kΩ recommended.
G3	MUTE	Digital CMOS Input. MUTE = high puts the device into mute mode. MUTE = low puts the device into normal operation mode.
F2	RESETB	Digital CMOS Input with Internal Pulldown to Ground. Device is reset when RESETB = low. Set RESETB low during device startup. RESETB must be set high for normal operation after startup.
K11	TDA	Temperature Sensor Diode Anode. Connect TDC and TDA to ground if not used.
M11	TDC	Temperature Sensor Diode Cathode. Connect TDC and TDA to ground if not used.
G4, H4, J4, G9, H9, J9	VDD2	1.8V Supply Input for Digital I/O
K6, K7	RCLKP, RCLKN	LVDS Reference Clock Output for Sample Rate Synchronization to Internal DACCLK at RF DAC Core. Equals DACCLK frequency at RF DAC core divided by DAC interpolation ratio (R). If not used, terminate with a 100Ω resistor differentially.
L6, L7, J2, H2, J11, H11	NC	No Connect
H1, J1	SYNCNP, SYNCNN	LVDS Output. Active low JESD204B error reporting signal (SYNC~) from Rx to Tx.
H12, J12	SYSREFP, SYSREFN	LVDS clock input used for JESD204B Subclass-1 operation (deterministic latency). Signal is synchronous to the device clock (DCLK = CLKP/CLKN) for all transmit and receive devices. Alternate function for multi-purpose pin SYNCIP, SYNCIN.
H12, J12	SYNCIP, SYNCIN	LVDS Input. Required for Multi-DAC Synchronization (Subclass-1). Alternate function for multipurpose pin SYSREFP, SYSREFN.
H3, J3	SYNCOP, SYNCON	LVDS Output used for Multi-DAC Synchronization under JESD204B Subclass-1. Multiple DAC synchronization is not supported in Subclass-0. If not used, terminate with 100Ω resistor differentially.
L8	VDD2PLL	JESD204B PLL 1.8V Power Supply
M7	VSSPLL	Clock Multiplier Unit (CMU) PLL Ground
L1, L3, L10, L12	DP0–DP3	Analog Input. JESD204B Serial Data Positive Input, Lanes 0-3
M1, M3, M10, M12	DN0–DN3	Analog Input. JESD204B Serial Data Negative Input, Lanes 0-3
M5	JRES	Analog Input. JESD204B Current Biasing.
M8	CAPT	Analog Input. JESD204B PLL Loop Filter Input.
L5	SYSREFEN	Hardwired SYSREF Enable CMOS Input. Use instead of SPI for improved timing control.

Functional Diagram

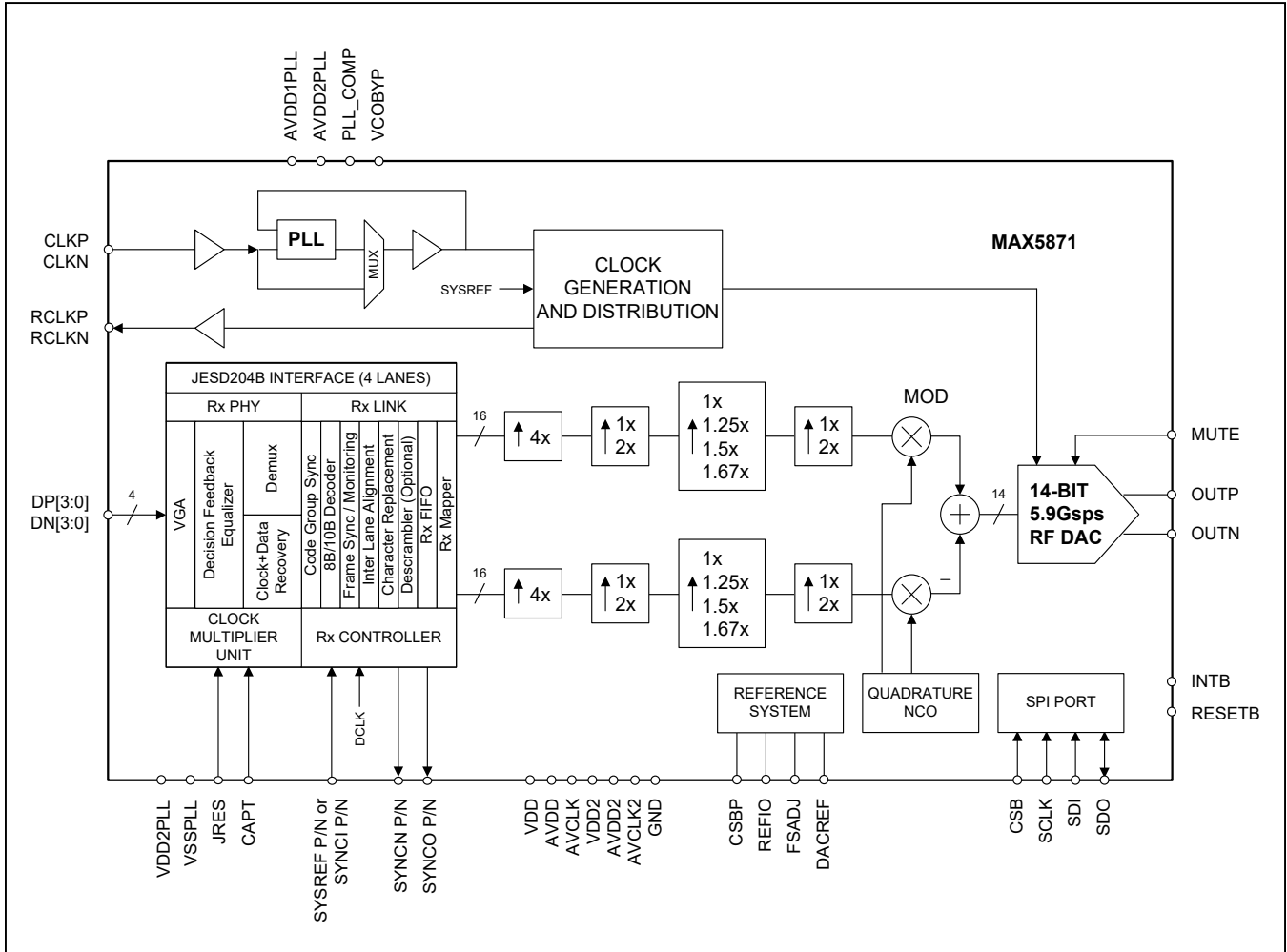

## Detailed Description

The MAX5871 is a high-performance interpolating and modulating 16-bit, 5.9Gbps RF DAC designed for wireless communications applications such as cellular base stations, multistandard and multiband transmitters, and point-to-point microwave links. The device can synthesize up to 600MHz of instantaneous bandwidth at frequencies up to the Nyquist bandwidth ( $f_{DAC}/2$ ) of the DAC. The major functional blocks of the device include a four-lane JESD204B interface which accepts 16-bit input data (I and Q), a cascade of interpolation filters, a digital quadrature modulator and NCO, clock multiplying PLL+VCO and a 14-bit, 5.9Gbps RF DAC core. The supporting functional blocks include the clock distribution system, reference system, and SPI interface. See the detailed *Functional Diagram*.

The 16-bit input data enhances the accuracy of the interpolation and modulation functions and ensures true 14-bit data is presented to the RF DAC core. The 16-bit input baseband data (I and Q) is supplied to the device using up to four lanes of JESD204B (DP[3:0]/DN[3:0]). The JESD204B interface can be configured for Subclass-1 for applications requiring deterministic delay and Subclass-0 for normal operation. The interface can be configured for 1, 2, or 4 lanes and supports serial data rates up to 10Gbps providing flexibility to optimize the I/O count, speed, and power to support the required frequency plan.

The four-lane JESD204B interface has the following major components:

- A high-speed input receiver (Rx) consisting of a physical (PHY) layer for each of the 4 lanes and a common clock multiplier unit (CMU). The PHY layer contains a variable gain amplifier (VGA) which receives the incoming signal and decision feedback equalizer (DFE) to suppress inter-symbol interference. The PHY layer also includes a clock and data recovery (CDR) unit to latch the incoming single-bit data and a Demux to de-serialize the data and convert it to a 20-bit parallel data bus.
- A receiver link layer (Rx Link) which takes the 20 bits from the PHY and restores the 16-bit DAC data for I and Q channel each. The Rx link consists of four Rx lanes, four Rx FIFOs, a Rx mapper and a Rx controller. The four Rx lanes perform code group synchronization, 8B/10B decoding, frame synchronization and monitoring, interlane alignment and monitoring, character replacement, and optional descrambling. The four lanes are fed into Rx FIFOs where data is aligned by the Rx controller. Using the Rx mapper, data from each physical channel is mapped to a logical channel.

The DSP path consists of a chain of configurable interpolation filters for I and Q channel each. Interpolation rates of 5x, 6x, 6.67x, 8x, 10x, 12x, 13.33x, 16x, 20x, or 24x can be selected by bypassing one or more of the interpolation filters. Interpolation reduces the required input data rate to the device relaxing the requirements on the FPGA or ASIC. In addition, interpolation increases the separation between the desired signal and its aliased image easing filter design requirements.

After passing through the interpolation stages, the complex signal is modulated using the LO signal generated by the NCO and the digital quadrature modulator. The NCO allows for fully agile modulation of the input baseband signal for direct RF synthesis with 32 bits of frequency-setting resolution. Placing the modulator at the output of the interpolator chain allows for fully agile placement of the output carrier frequency within the Nyquist bandwidth of the DAC. The quadrature modulator produces a real signal at its output, which is in turn fed into the 14-bit DAC core where it is converted to an analog RF signal. The analog output produces a full-scale current between 10mA and 30mA driving loads up to 50Ω differential.

The clock distribution system provides a low-noise differential input buffer for the external master DAC clock (CLKP/CLKN) and delivers all necessary clocks to all the DAC blocks. The master DAC clock input accepts a differential sine-wave or square-wave signal. An integrated clock multiplying PLL and VCO can be used to generate a high-frequency clock in the range from 4.4GHz to 4.9GHz or at 5.9GHz. The PLL can be bypassed allowing use of an external clock source. The device outputs a divided reference clock (RCLKP/RCLKN) that is equal to the DAC clock frequency divided by the DAC interpolation ratio to ensure synchronization with the system clock. The SYSREF clock input is used for Subclass-1 operation (deterministic latency) and is synchronous to the device clock (DCLK = CLKP/CLKN) for all transmit and receive devices. The SYNCN output is used for error reporting from the receiving device (MAX5871) to the transmitting device (FPGA or ASIC). The SYNCO output is used to synchronize multiple MAX5871 devices.

The reference system delivers the reference current to the DAC current source array and all bias currents necessary for the circuit operation. The reference system also includes a band-gap reference, which can be used as a reference for the DAC full-scale current. The SPI port is a bidirectional interface and is used for configuring the device and reading/writing status and control registers. The device operates from 1.8V and 1.0V power-supply voltages and consumes 2.5W at 4.9Gbps.

**JESD204B Interface**

The MAX5871 JESD204B interface consists of four lanes of physical layer (PHY) with a common clock multiplier unit (CMU). Each lane takes a serial 1-bit stream and converts it to a parallel 20 bit bus. The link layer (LINK)

takes the 20 bits from the PHY and restores the original 16-bit DAC data for the I and Q channels. See Figure 1. The MAX5871 JESD204B receiver specifications are compliant with the LV-OIF-6G-SR and LV-OIF-11G-SR specifications from the JESD204B standard.

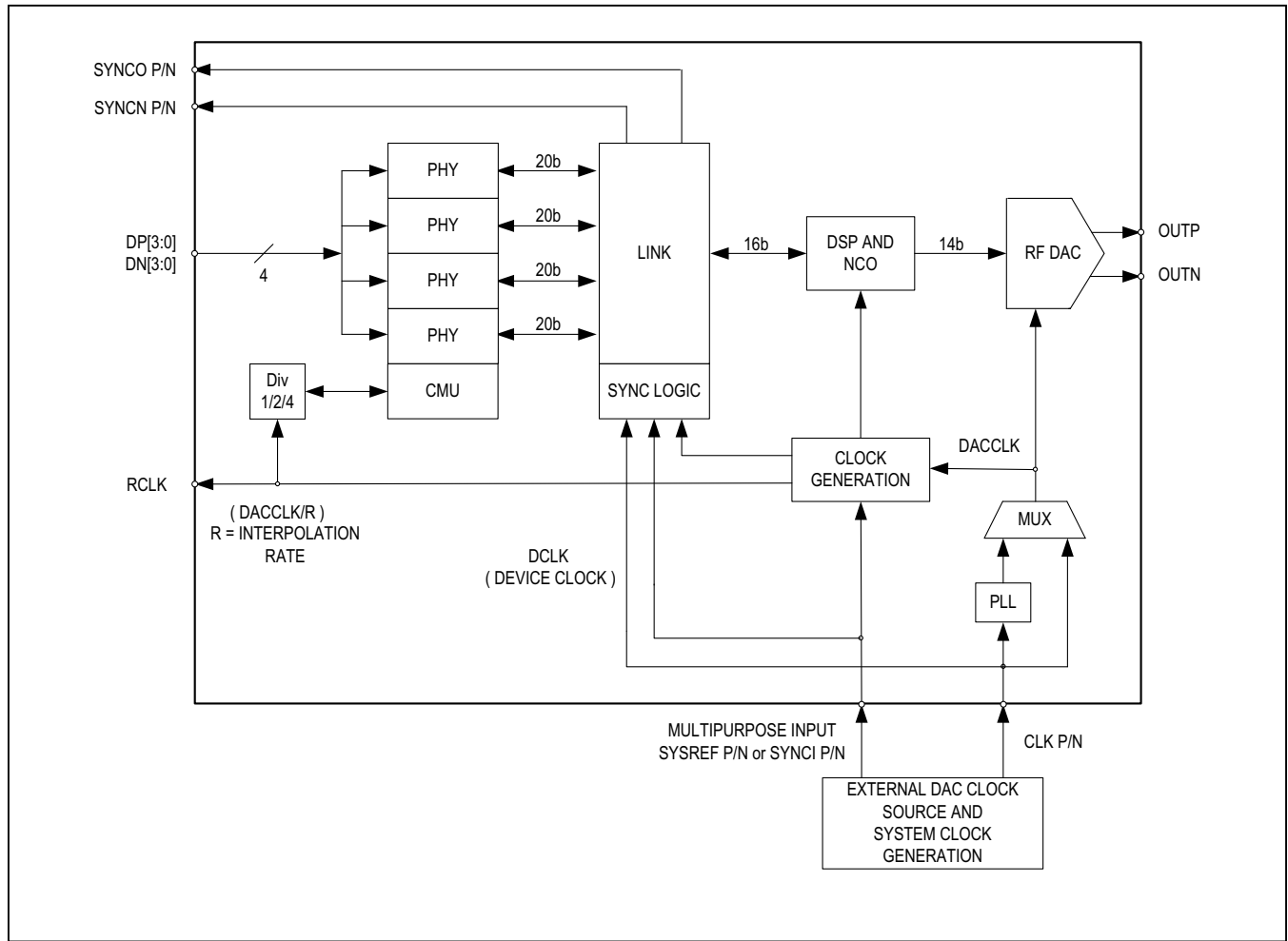

Figure 1. Simplified Diagram of JESD204B Internal to MAX5871

**Table 1. JESD204B Receiver Power Dissipation**

BLOCK	NO. of JESD LANES	TOTAL ESTIMATED POWER (PHY+CMU+LINK) (mW)
	(7.3728Gbps/LANE)	
LINK RX-1	1	200
LINK RX-2	2	322
LINK RX-4	4	563

**JESD204B Data Interface Features**

A summary of the MAX5871 SerDes PHY (Rx) and link features are provided below.

**Rx PHY Key Features**

- Programmable Gain
- Decision Feedback Equalizer. Fully configurable as to which coefficients to enable/disable.
- Auto adaptation available for all DFE coefficients, gain, boost.

**Link Key Features:**

- 8b10b decoding
- Code Group Synchronization
- Inter Lane Alignment (ILA)
- $1 + x^{14} + x^{15}$  Polynomial Scrambling
- Character Replacement
- Dynamic on-the-fly frame/lane realignment if the elastic buffer allows it
- Multiple Converter Device Alignment-Multiple Lanes (MCDA-ML) device
- Subclass-0 and Subclass-1 support
- Number of lanes (L): 1, 2, 4
- Number of data converters or I and Q paths (M): 2
- Number of octets per frame (F): 1, 2, 4
- Number of samples per frame (S): 1, 2

**Other Features:**

- Scrambling disable mode
- Elastic buffer depth of 320 serial bit periods

- Detection of following 8b10b control characters: K28.0, K28.3, K28.4, K28.5, K28.7
- Detection of following errors/conditions
  - 8b10b Running Disparity Error
  - 8b10b Not-in-table Error
  - Unexpected Control Character Detection
  - Code Group Synchronization Error
  - Frame Realignment Detection
  - Lane Realignment Detection
  - ILA Failure Detection
  - Link Configuration Error
  - ILA Sequence Error
- Various errors can be enabled to trigger resynchronization through SYNC~ interface
- Continuous /K/ and continuous ILA sequence detection
- Error reporting via the SYNC~ interface
- Data repetition from previous frame/sample on not-in-table error detection
- Sample PRBS data for debug
- SerDes PRBS data for debug

**High-Speed Input Receiver (Rx)**

As shown in Figure 2, the high-speed input receiver consists of a variable gain amplifier (VGA), decision feedback equalizer (DFE), clock and data recovery (CDR) unit and deserializer (DEMUX). The VGA and DFE provide **autonomous adaptive** effective equalization to optimize the input receiver filter coefficients to best recover the data dependent jitter introduced by the incoming channel. The initial receiver gain and equalization settings are shadowed by internal registers and may be overridden and driven by the user.

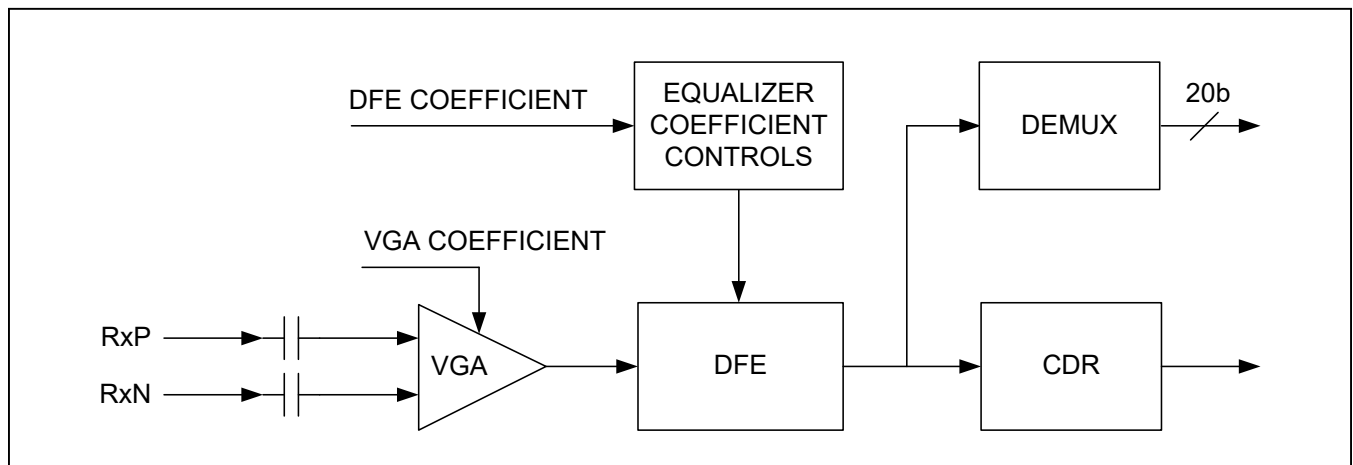

Figure 2. JESD204B Rx Physical Layer Simplified Block Diagram



The VGA is a high-speed input receiver that has high gain, which allows for excellent input sensitivity while still preserving the linearity required for optimal performance of the DFE. The receiver expects the incoming high-speed signal to be differentially driven and AC-coupled to the transmitter. The receiver common-mode voltage is set by a self-biasing network, eliminating the need for any external board circuitry. The receiver provides on-chip termination between the true and complement input signals, RxP and RxN (typically 100Ω differential). The VGA gain settings are set based on the amplitude of the incoming high-speed signal and the optimal setting to the DFE circuitry and the VGA gain range is (±20dB). In addition to the gain function, there is also a boost function in the VGA to compensate for the high-speed frequency loss in the channel as shown in Figure 3.

The PHY receiver provides a sophisticated level of equalization to suppress inter-symbol interference (ISI)

caused by a dispersive channel known as decision feedback equalization. The DFE makes use of previously determined data to estimate the current bit. Any trailing ISI caused by a previous bit is reconstructed and then subtracted. This technique allows for the recovery of very lossy backplane and connector channels. The PHY equalizer is designed to meet or exceed the JESD204B standard.

The clock and data recovery unit is responsible for the centering of the incoming data eye for optimal sampling and error-free operation. The PHY clock and data recovery unit has multiple loop bandwidth settings to aid in optimal performance for jitter tolerance.

The recovered clock generated from CDR is used to latch in the single-bit data, then the DEMUX block deserializes the single bit to 20-bit parallel data bus to be used by Rx Link.

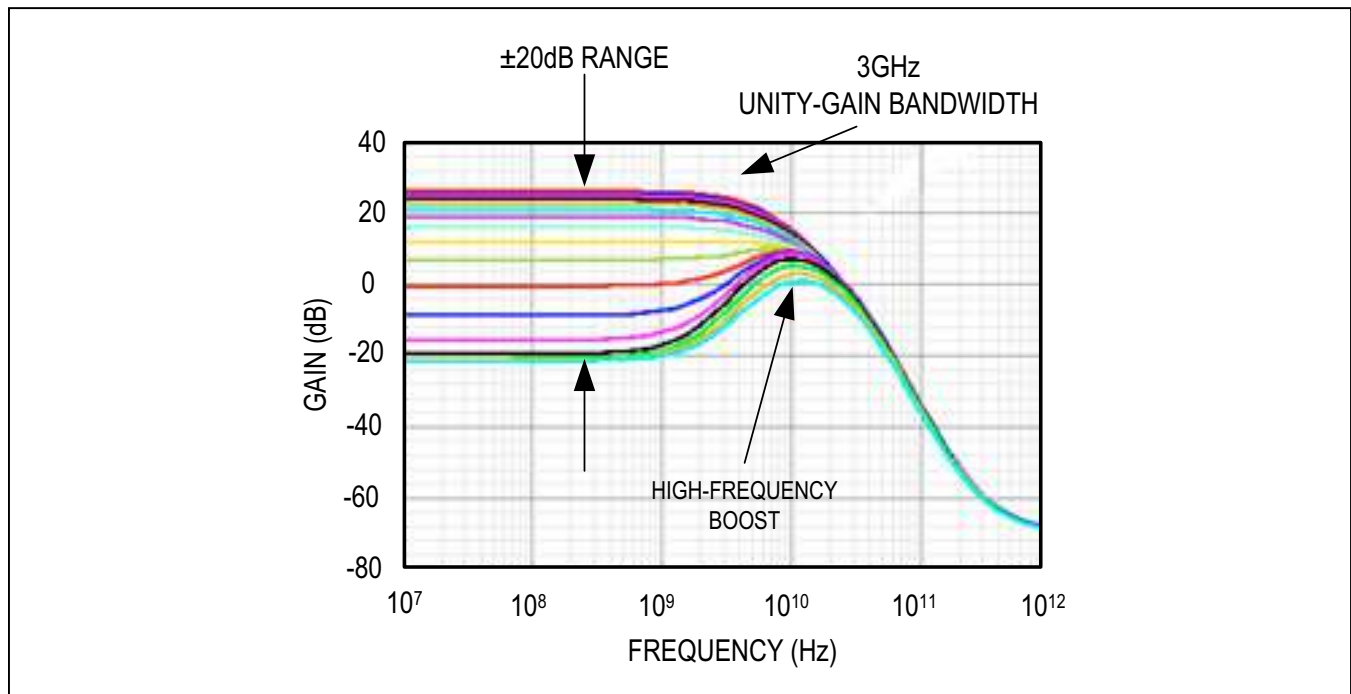

Figure 3. VGA Gain Range

**JESD204B Receiver Equalization**

This section demonstrates the JESD204B receiver equalization capability over a long length of cable (30in); however, use of cables of this length is not recommended. The MAX5871 is designed for and meets the JESD204B 20cm trace length requirement with a given set of internal configurations.

**Device Configuration**

Serial Data Rate: 9.8304Gbps  
Xilinx® VC707 FPGA Data Source  
Channel: 30in Nelco 4000-13SI plus cables and FMC connector  
30in Nelco Traces = -14.7dB loss at 4.914GHz  
Cables and connector ~ 3dB loss at 4.914GHz

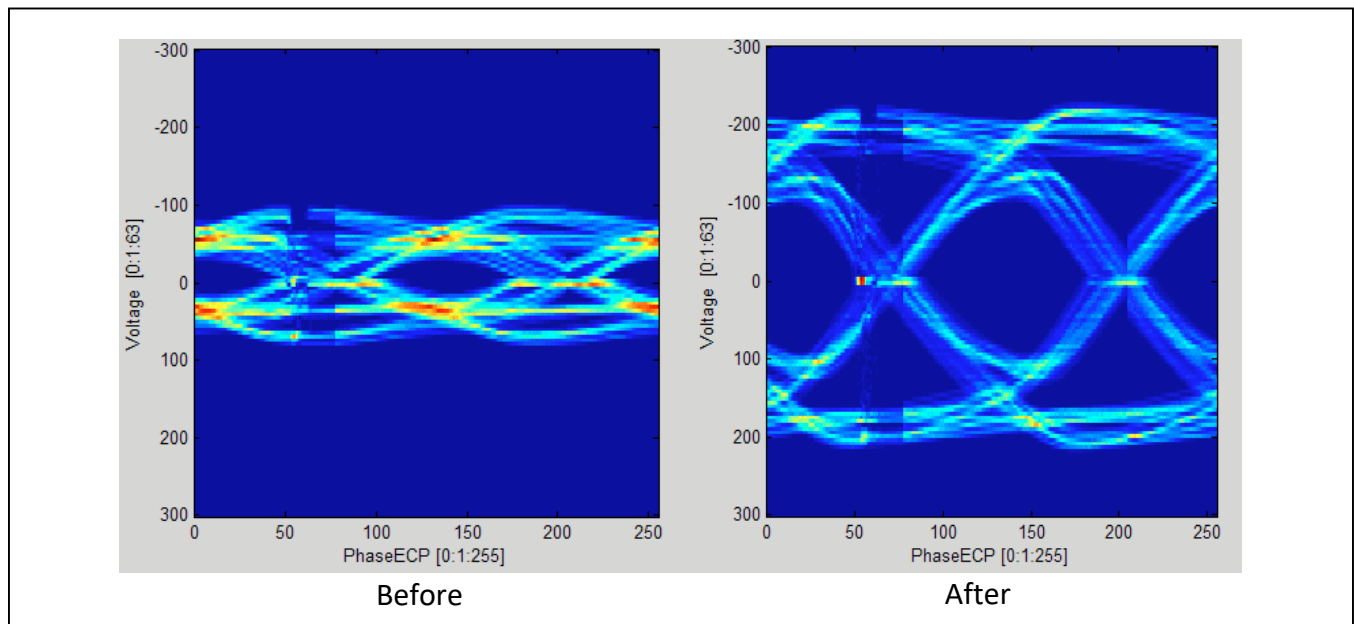

Figure 4. Receiver Equalization Eye Diagram Before and After Lane Training (9.8304Gbps, 30in Nelco Trace)

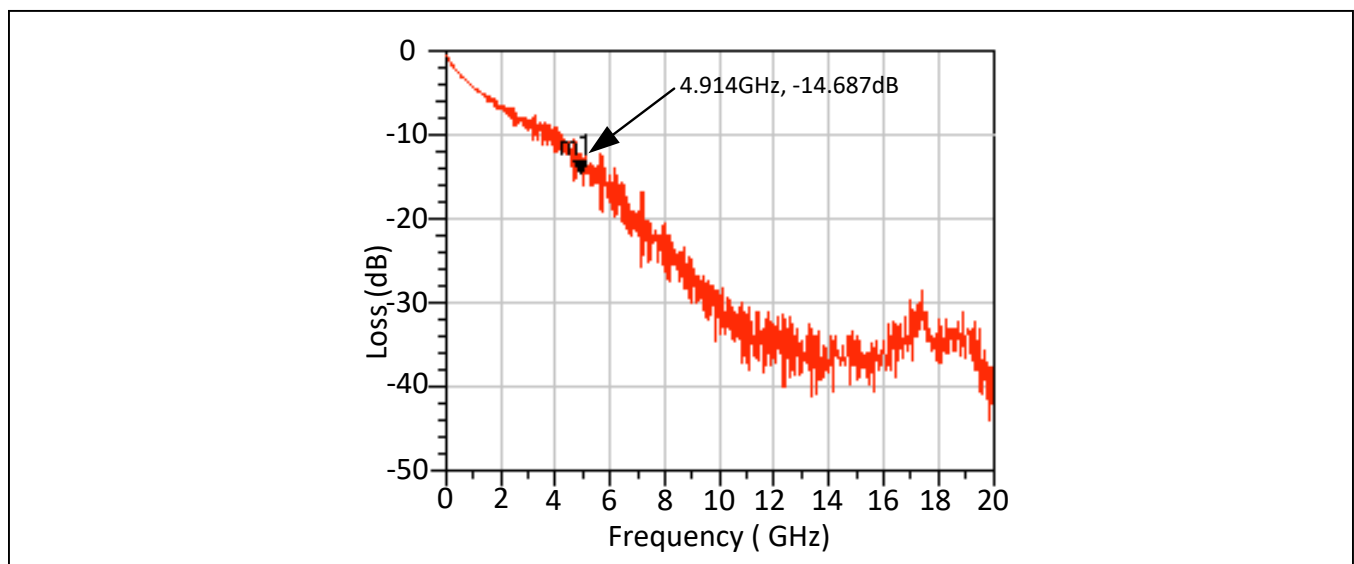

Figure 5. Channel Loss Curve (30in)

**Synchronization with SYSREF**

A JESD204B Subclass-1 device achieves deterministic delay through a clock-and-sync interface as specified in the standard. The SYSREF input is synchronous to the device clock (DCLK=CLKP/N) input for all the receive and transmit devices. SYSREF is sampled on the rising edge and then used to reset the phase of the divided clock(s). One of the divided clocks is configured as the sample clock. An extended version of the sampled SYSREF is used to reset the octet and frame counters running on the sample clock. Deterministic delay is achieved by synchronizing the phase of all sample clocks and octet/frame counters and configuring the same point in time for the FIFO read start across all the devices. The transmit logic device (FPGA or ASIC) generates data at the same time for all the receive devices (multiple DACs). After this resynchronization, the data read out of the FIFOs in all the receive devices is triggered at the same time achieving deterministic delay.

The timing diagram (Figure 6) shows the SYSREF signal usage for a JESD204B Subclass-1 device. DCLK is the device clock, SAMCLK is the sample clock, OCNT is the octet counter holding the octet count in a frame and FCNT is the frame counter holding the frame count in a multiframe (as specified in the JESD204B standard). The SYSREF signal essentially sets the phase of the frame and multiframe clocks implemented as octet and frame counters.

The maximum device clock (DCLK) frequency is twice the specified maximum input sample rate of 737.28MHz. This means the SYSREF timing window, for the transmit logic device and the receive device together, is 500ps. This results in tight setup and holds constraints on the DCLK/SYSREF timing, even though it is a source synchronous interface. To enable sufficient margins for sampling of SYSREF on DCLK, a programmable delay on SYSREF needs to be implemented with steps of 10's of ps so that the timing can be adjusted at each of the receive device inputs.

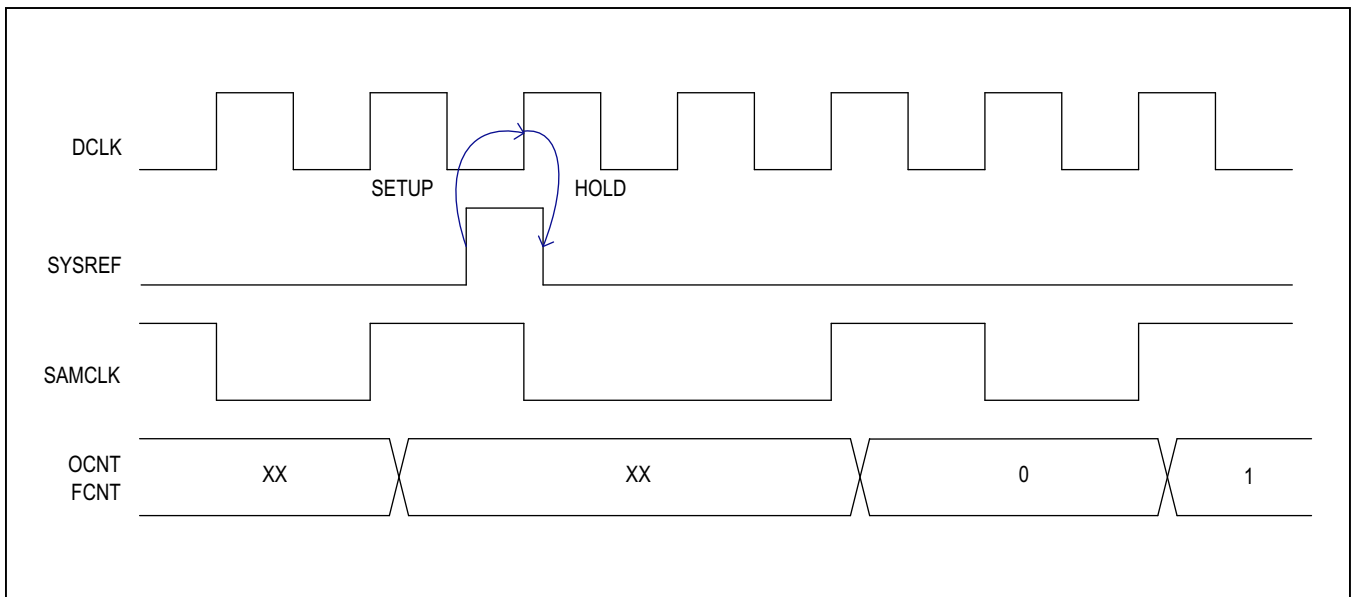

Figure 6. SYSREF Usage for Sample Clock (DLCK/2) Generation and Synchronization

An additional mode to replace the device clock source is to generate the sample clock by dividing down the DACCLK in the DSP section. In this mode, there will not be a device clock and the SYSREF input will be an asynchronous signal. For multi-DAC synchronization, the JESD204B link will not have a deterministic delay but the overall skew within one DAC clock cycle. The SYSREF signal will be passed through to the DSP block where it

is used to reset the clock-divider circuit and generate a synchronous signal to RCLK (reference clock at sample rate). This synchronization will occur with one DAC clock uncertainty. The synchronous signal RSYNC is used by the Rx Link block to reset its frame counters. See Figure 7 for the timing diagram for this mode.

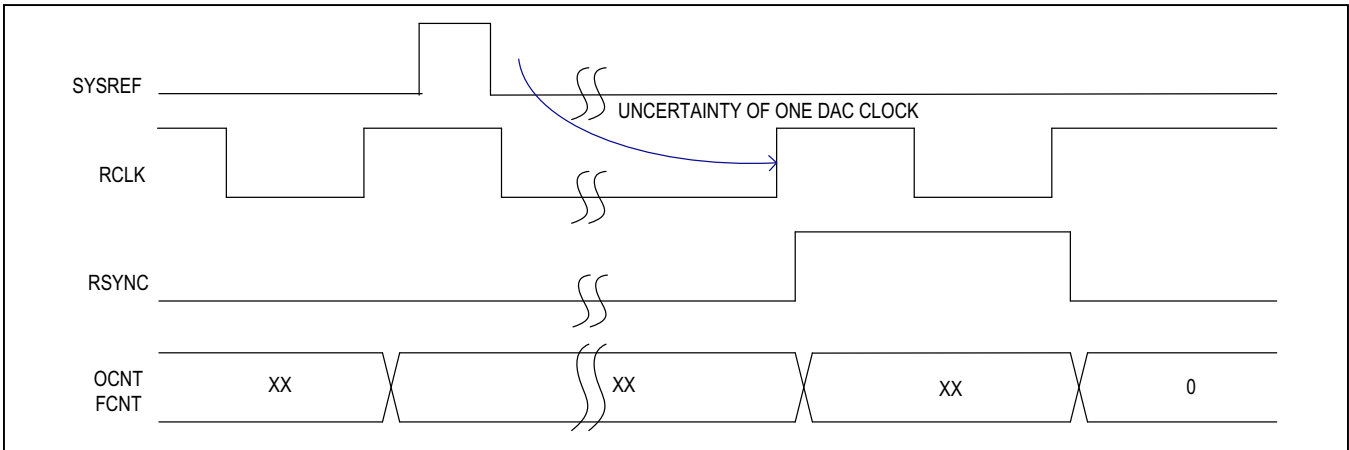

Figure 7. SYSREF Usage for Sample Clock (From DACCLK) Generation and Synchronization

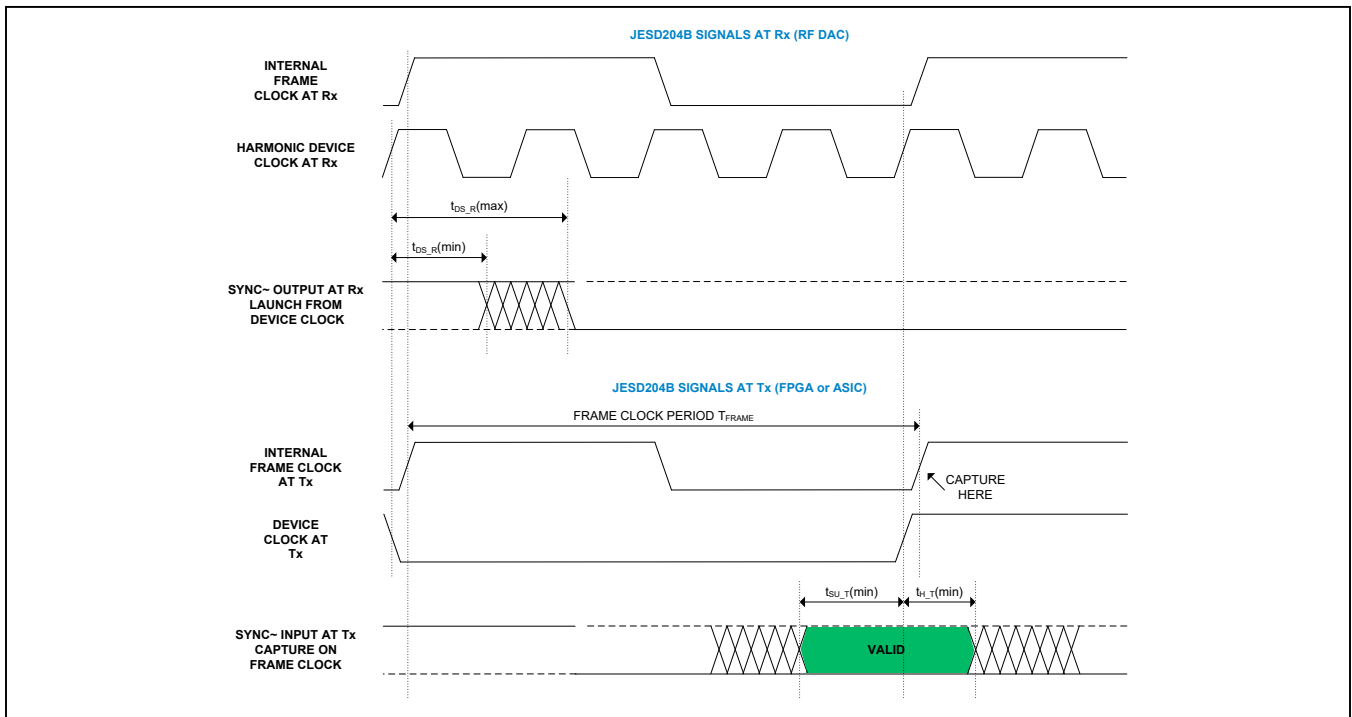

Figure 8. Interface Timing for Subclass-0 (See JEDEC Standard No. 204B.01, Figure 11)

**Link Layer (LINK)**

The Rx link layer for the MAX5871 consists of 4 lanes interfacing to the 4 PHYs. The data from the 4 lanes is passed through FIFOs controlled by a Rx controller used to align the data on all the configured number of lanes in both JESD204B Subclass-0 and Subclass-1 modes. The Rx controller also handles the Subclass-1 deterministic latency using the input device clock (DCLK=CLKP/N) and SYSREF signals. The Rx controller also generates the SYNCN signal for error reporting as specified by the JESD204B standard. The data from the FIFOs, used to absorb the lane skews, is then mapped into I and Q sample data for the DSP to process.

Each of the 4 lanes in the Rx link operates independently and includes code group synchronization operating on the 20-bit input from the PHY, 8b10b decoding, frame synchronization and monitoring, lane alignment and monitoring, character replacement and optional descrambling. All these functions are specified in the JESD204B standard. In addition to extracting the octets, which are later combined into I and Q samples, the Rx Lane also monitors and acts on various error conditions. Most error conditions can be enabled to trigger a resynchronization request from the transmit logic service through the SYNCN signal. See *Link Layer Configuration Registers* for more detail.

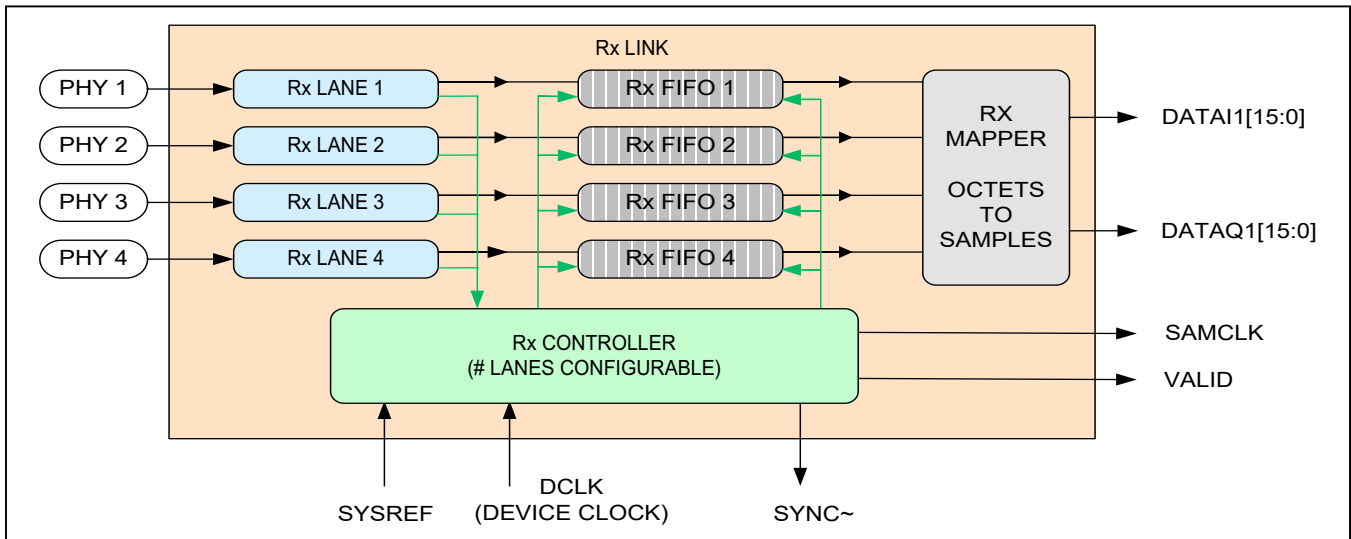

Figure 9. JESD204B Receive Link Layer Block Diagram

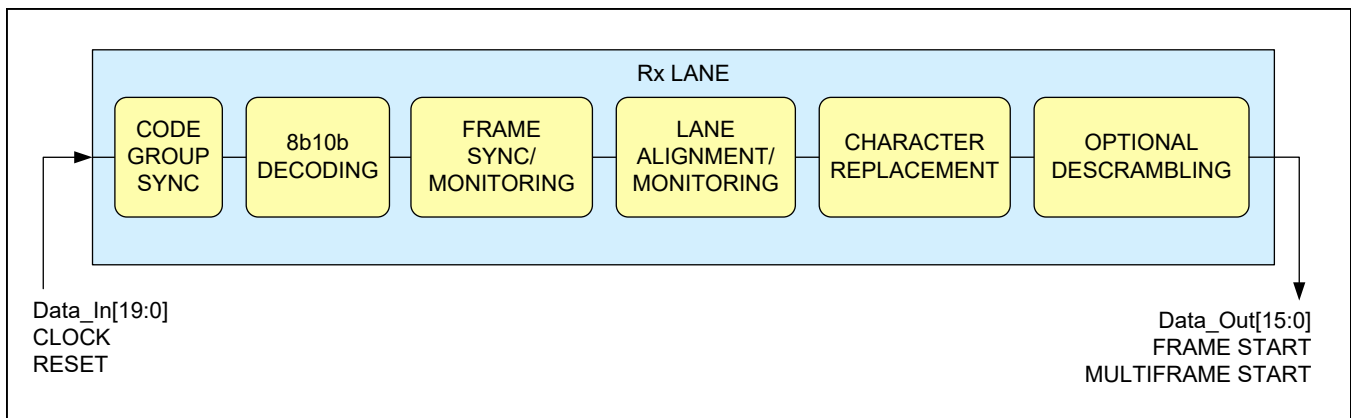

Figure 10. JESD204B Receive Lane Block Diagram

On the input side of the Rx lane are 20-bit data and the clock from the PHY along with a synchronous reset. On the output side are 16-bit data (two octets) and frame/multiframe start signals marking the two bytes of data.

**Lane Skew Requirement**

The skew between the various lanes is absorbed within the FIFOs and through the initial lane alignment process. The FIFO depth determines the amount of lane skew that can be absorbed for a particular Rx Link configuration. A FIFO depth of 32 bytes would account for up to 320 SerDes bit periods of skew between the various lanes. In actuality, the maximum supported skew is smaller than this due to multiple bytes written to and read from the FIFO in a single write/read clock cycle in various modes. The maximum supported skew is also reduced due to the write clock to read clock synchronization uncertainty. A minimum and maximum FIFO depth can be set and the overflow/underflow configured to trigger resynchroniza-

tion from the transmit logic device. The configured FIFO range determines the actual lane skew supported by the MAX5871.

**Mapping of Physical to Logical Channels**

Each physical channel can be mapped to any logical channel before the octet to sample conversion. The octet to sample conversion for various modes as determined by the number of lanes (L), number of octets per frame (F) per JESD204B, and the number of samples per frame (S) is according to the formats shown below.

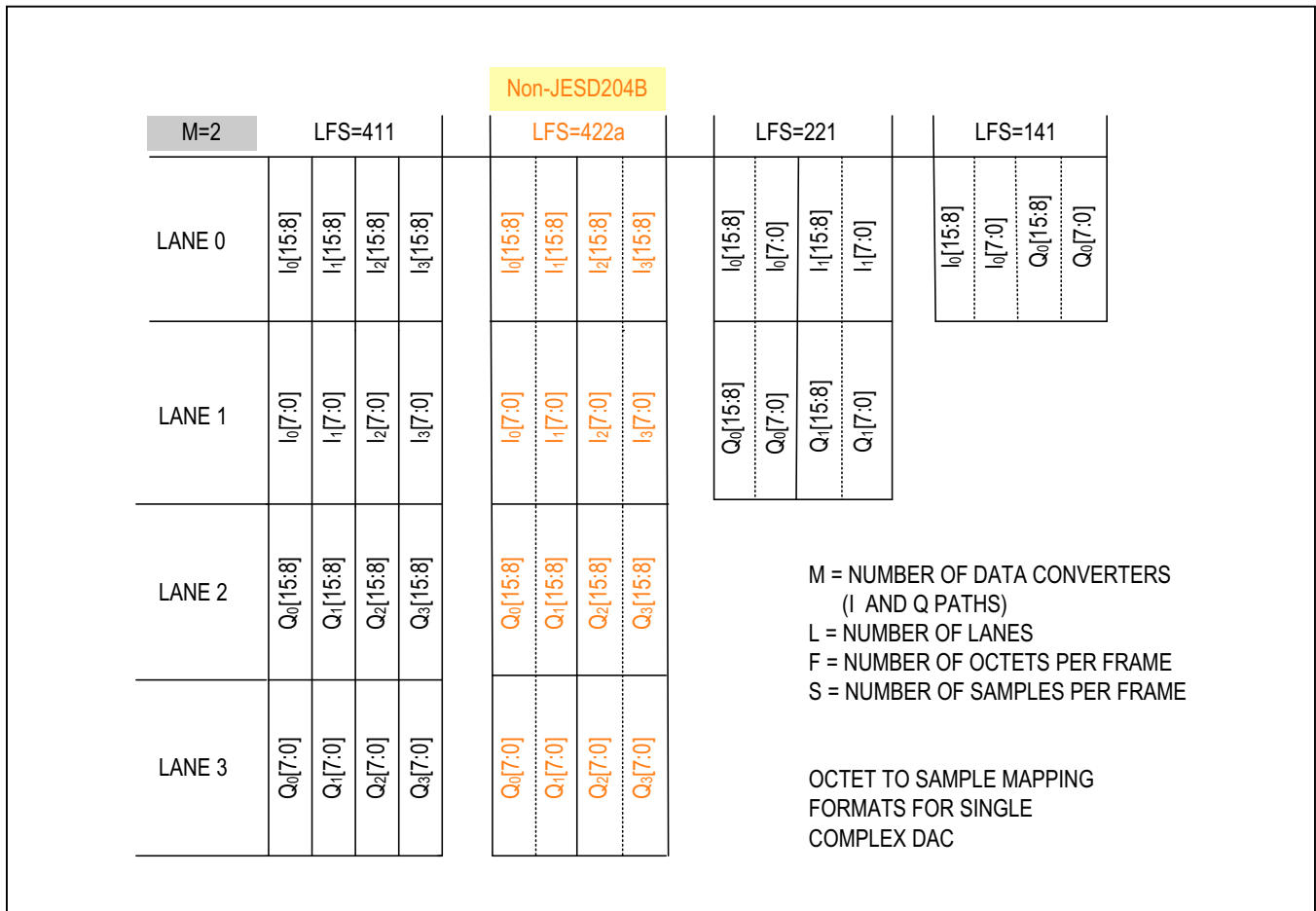

Figure 11. Octet To Sample Conversion vs. Modes and Lanes

**Serial Control Interface**

The serial control interface is composed of the CSB, SCLK, SDI, and SDO pins. It supports typical 4-wire SPI interface (CSB, SCLK, SDI, and SDO) where pin SDI is the digital data input, and a typical 3-wire interface (CSB, SCLK, and SDI) where pin SDI is both digital data input and output. In the 3-wire interface mode, the SDI pin is identical to the SDIO pin, as identified in a typical 3-wire interface in some literature.

The MAX5871 is always a slave device with the master controlling CSB, SCLK, and SDI. In 4-wire SPI interface mode, CSB, SCLK, and SDI are CMOS-level digital input pins, with a 1.8V input range. SDO is high impedance except when the MAX5871 is transmitting serial data. SDO is a CMOS output signal with a 1.8V output range. CSB is the chip-select pin. While in the low state, a MAX5871 device is open to communication through the SCLK, SDI, and SDO pins. Each communication cycle is composed of a read/write bit, an address word, and a write data word or a read data word. The serial interface clock, SCLK, latches data into the MAX5871 on the rising edge and clocks data out of the MAX5871 on the falling edge. A one for the R/W bit signifies a read operation and a zero indicates a write operation. A write operation is defined as the controller writing a data word to the MAX5871. A read operation is when the MAX5871 serial interface transmits a data word back to the controller.

Both the R/W bit and the address word are sent to the MAX5871 through the SDI pin. The address word is 15

bits wide and is transmitted MSB to LSB in the default MSB-first mode. In the LSB-first mode, the address word is transmitted LSB to MSB followed by the R/W bit.

For a write operation, a data word is immediately written to the MAX5871 after the last control word (R/W or address word) bit. The data word is 8 bits wide and is transmitted from the external controller, MSB to LSB in the default MSB-first mode. For a read operation, the data word is transmitted from the MAX5871 on the SDO signal line. The transmission starts on the falling edge of SCLK immediately after the last control word bit is latched into the MAX5871. Again the data word from the MAX5871 is transmitted MSB to LSB in the default MSB-first mode. The SDO driver enters a high-impedance state on the next falling SCLK edge immediately after the control word LSB is transmitted. CSB must toggle from low to high and then back down to low before another communication cycle can resume if burst mode is turned off. The SDO and SDI signals can be tied together to achieve an SDIO communication pin.

In the non-default LSB-first mode, the data word is transmitted LSB to MSB both for writes and reads. When burst mode is enabled, a continued assertion of CSB after the data word would auto decrement/increment the address word depending on the configuration for a successive read/write. Every 8 cycles of SCLK would access a successive address for either write or a read based on the R/W bit in the initial control word.

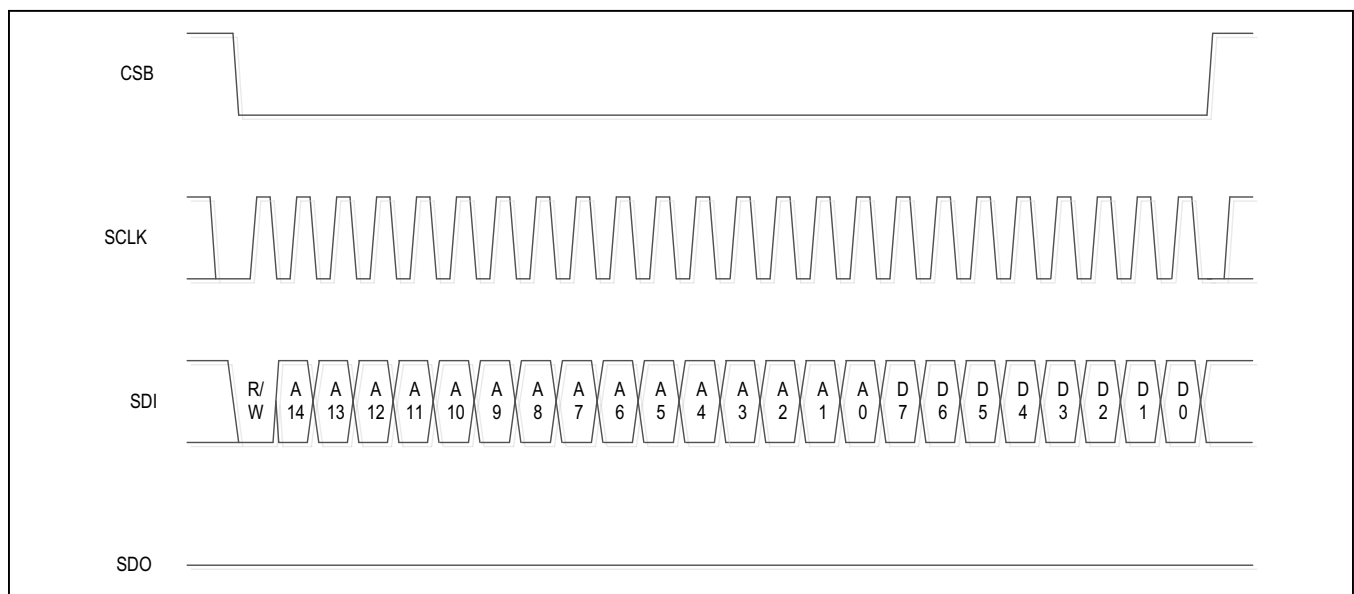

Figure 12. Single SPI Write Transaction with MSB-First

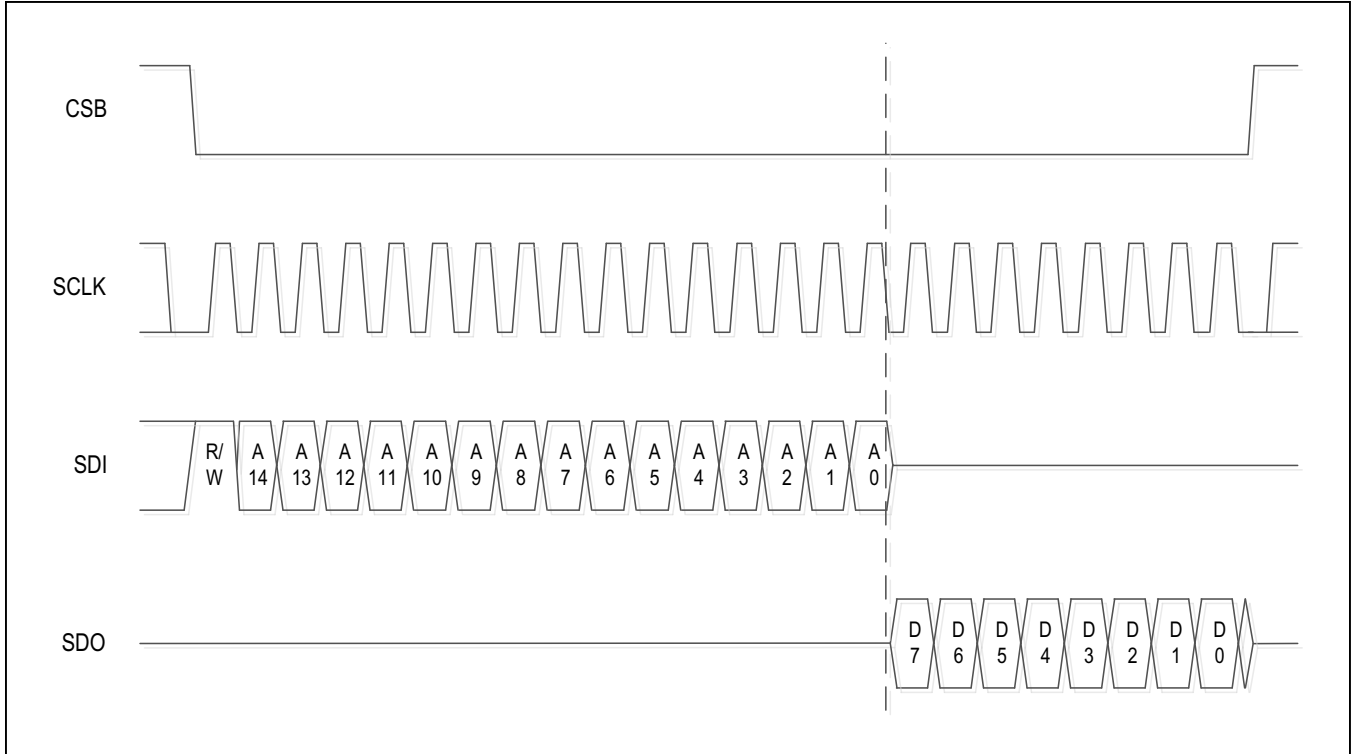

Figure 13. Single SPI Read Transaction with MSB-First

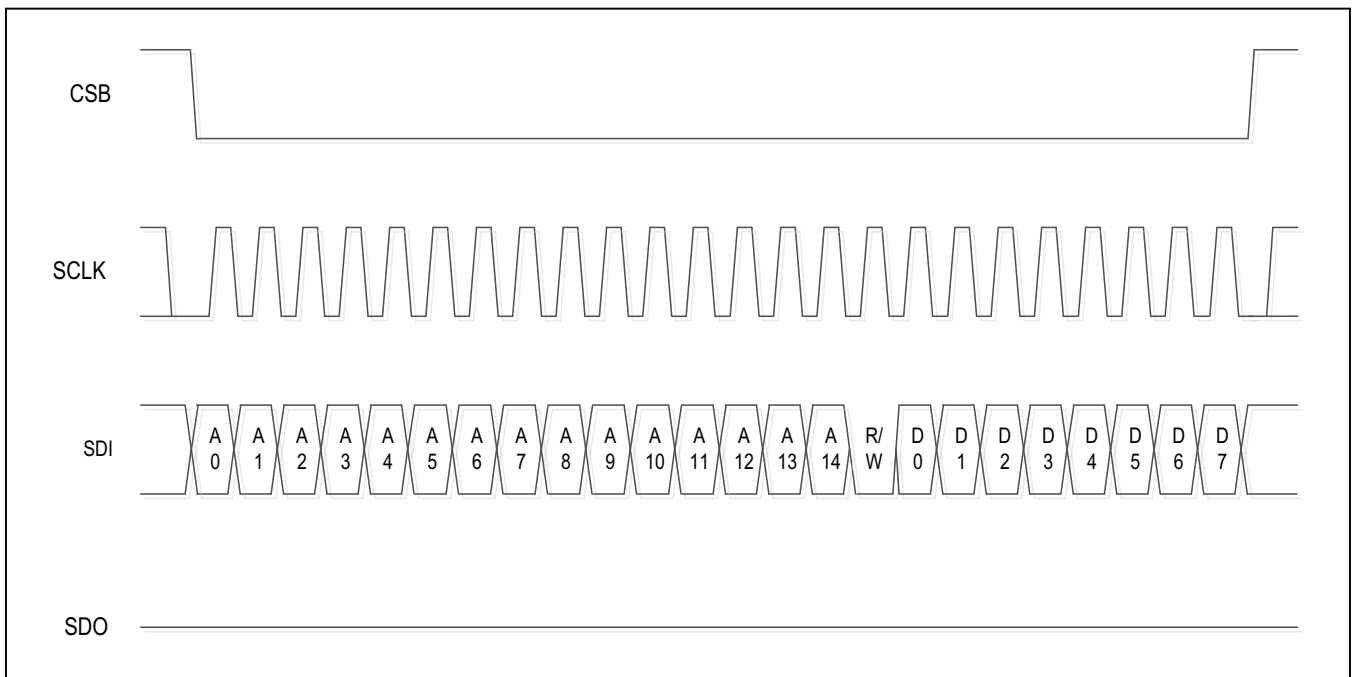

Figure 14. Single SPI Write Transaction with LSB-First



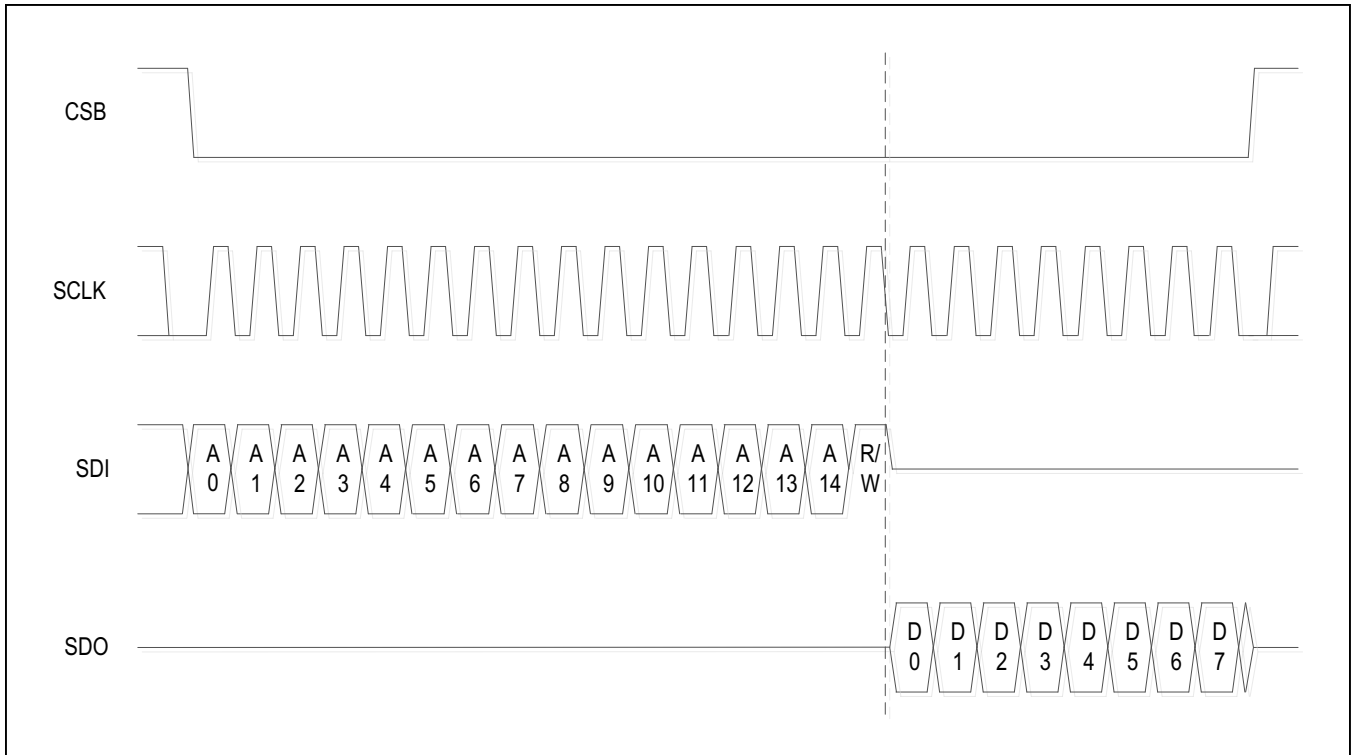

Figure 15. Single SPI Read Transaction with LSB-First

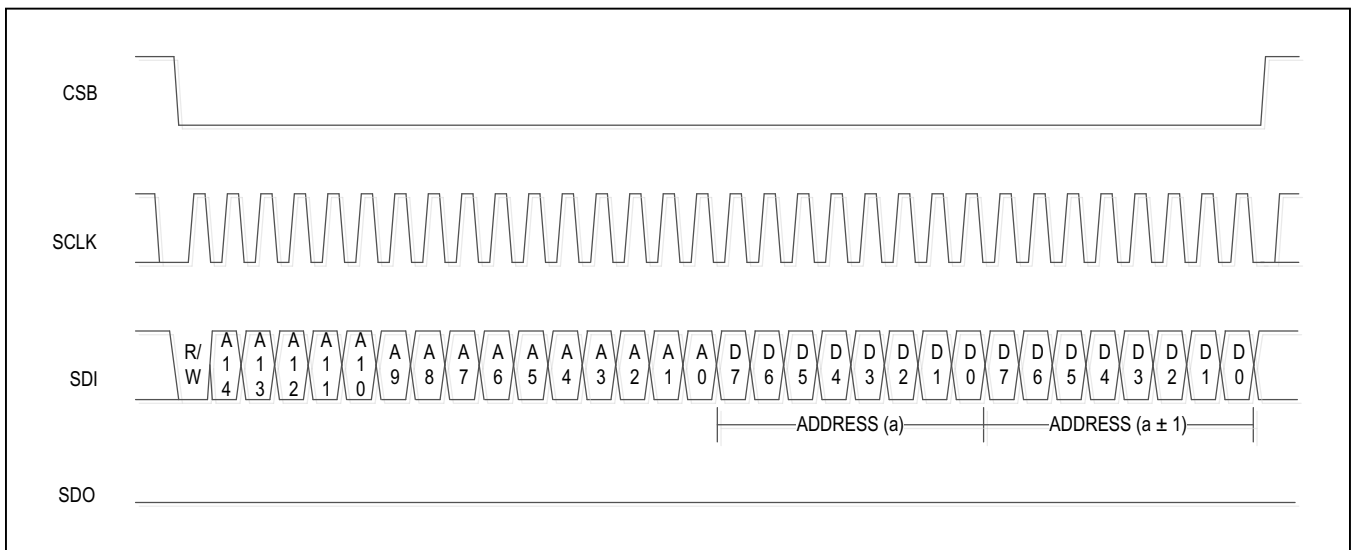

Figure 16. Burst SPI Write Transaction with MSB-First

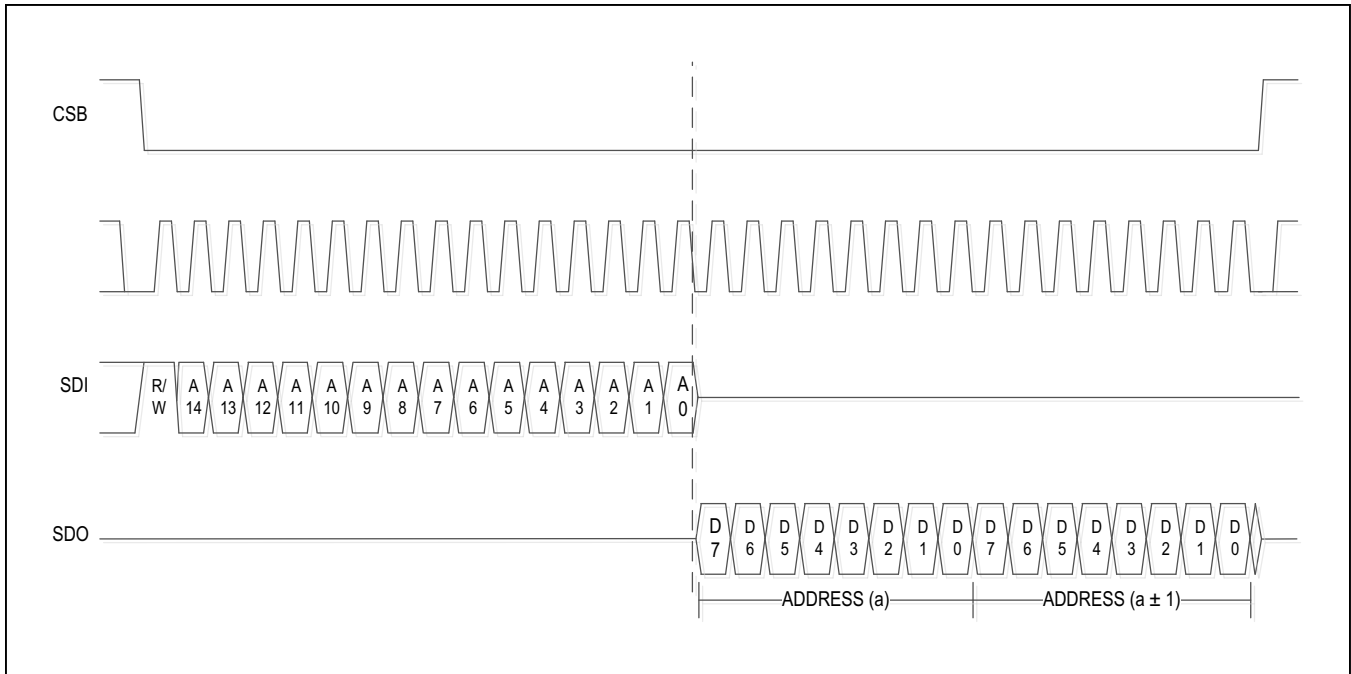

Figure 17. Burst SPI Read Transaction with MSB-First

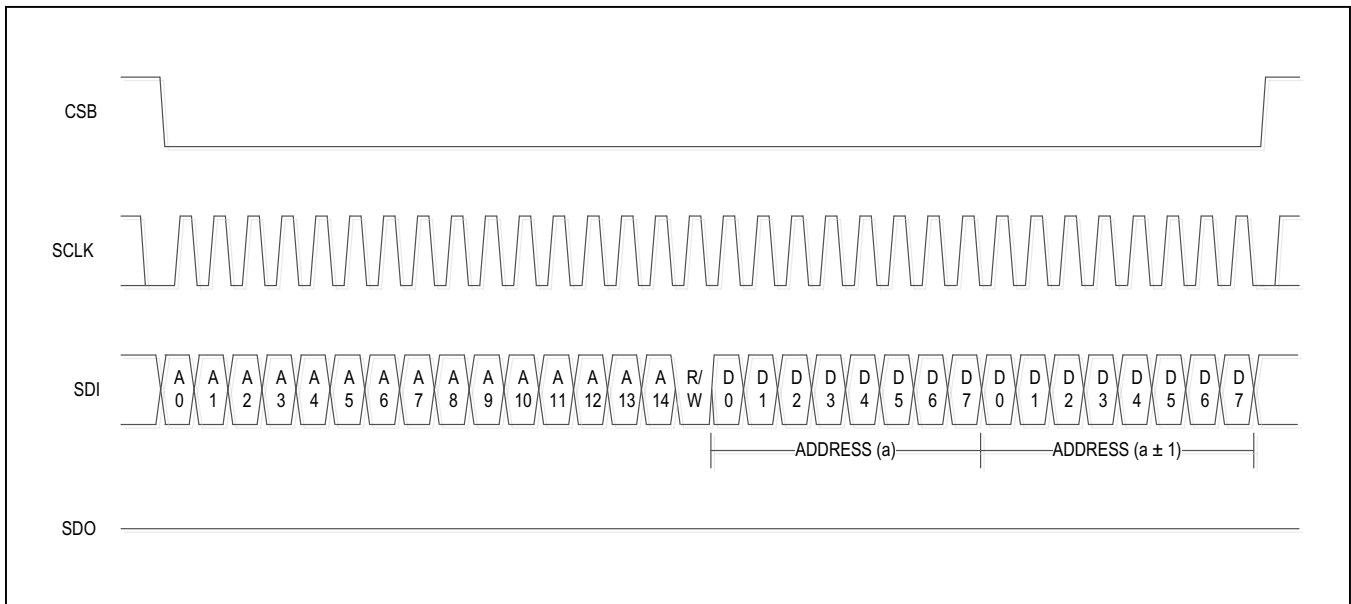

Figure 18. Burst SPI Write Transaction with LSB-First

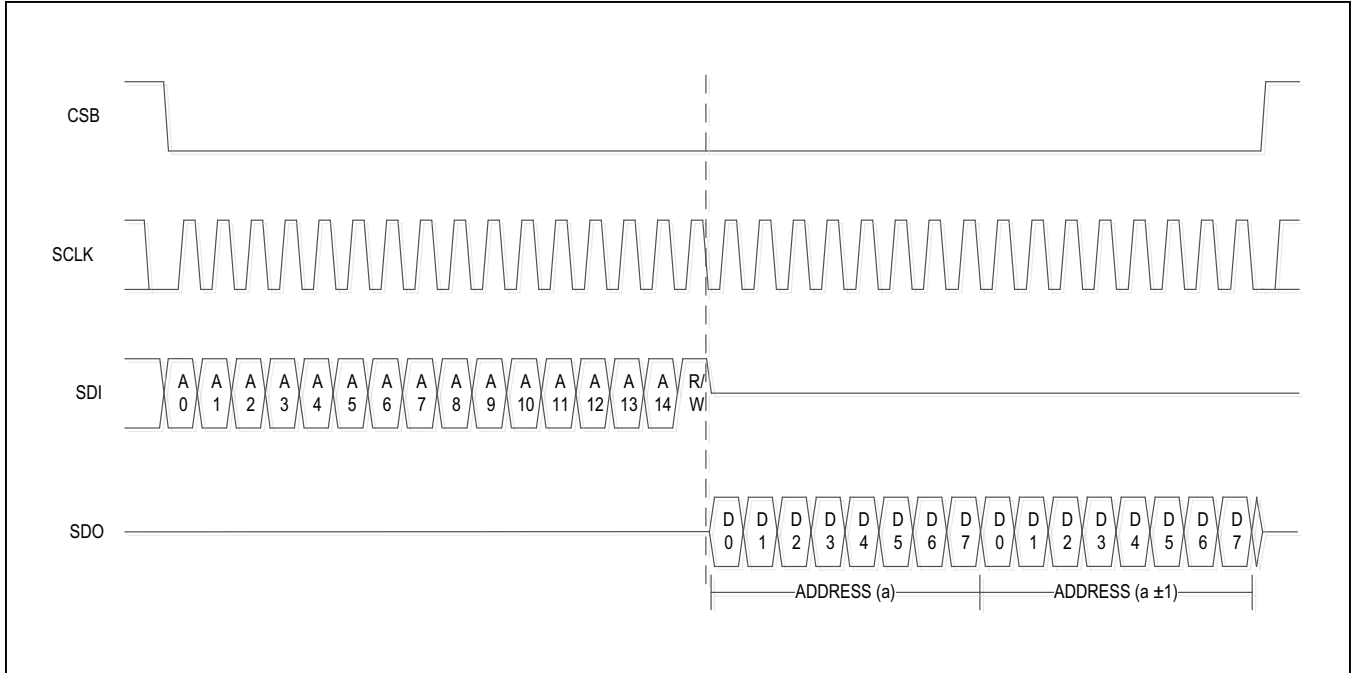

Figure 19. Burst SPI Read Transaction with LSB-First

**Interrupt and Mute**

The INTB pin is a CMOS output port that signals an interrupt condition when in the low state. The interrupt system is composed of an interrupt register and an interrupt mask. The interrupt signal is a logic NOR of the bit-wise AND operation of the interrupt register and the interrupt mask. In the MAX5871, 7 interrupt bits are defined: 2 bits for JESD204B mute and interrupt status, 3 bits for a FIFO collision (1-away and 2-away), 1 bit for trim ready, and 1

bit for DAC PLL unlock status. The interrupt tree for the MAX5871 is shown in Figure 20. The JESD204B interface has its own second level of interrupt registers and interrupt mask registers as defined in the register interface. The interrupt mask and register can be modified through the serial interface. Table 2 shows all the status register bits that can be enabled to generate an interrupt.

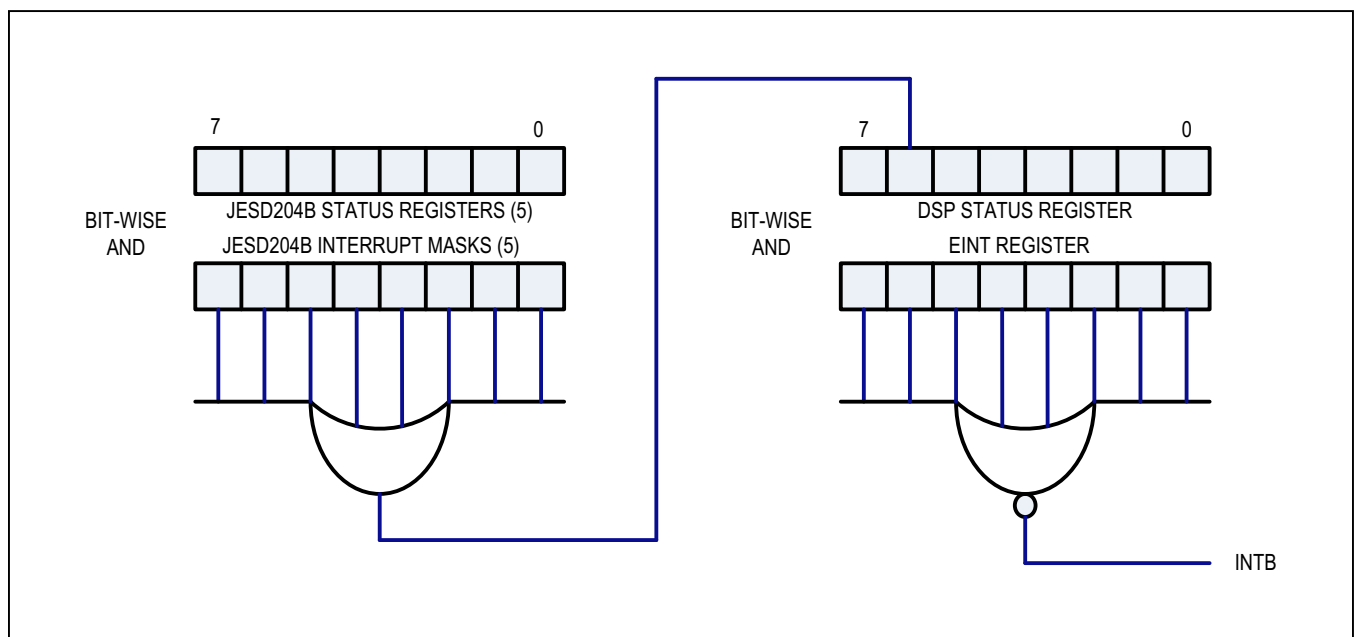

Figure 20. MAX5871 Interrupt Tree

**Table 2. MAX5871 Status Register Bits**

DSP STATUS REGISTERS (1ST LEVEL INTERRUPT)	
BANK.REGISTER.BIT	FUNCTION
DSP.STATUS.JSDIM	Real-time status indicating DAC mute from JSDI link layer is active
DSP.STATUS.JSDII	Real-time status indicating interrupt from JSDI link layer is active
DSP.STATUS.FCOL	Latched status set when the input FIFO write and read pointers collide causing FIFO underflow or overflow
DSP.STATUS.F1A	Latched status set when the input FIFO write and read pointers are away from each other by one sample
DSP.STATUS.F2A	Latched status set when the input FIFO write and read pointers are away from each other by two samples
DSP.STATUS.TRDY	Latched status set when trim loading load is complete and the SPI bus is unblocked for external access
DSP.STATUS.PLLck	Latched status set when the DAC PLL is unlocked

JESD204B STATUS REGISTERS (2ND LEVEL INTERRUPT)	
BANK.REGISTER.BIT	FUNCTION
LNK.StatLane.InNfnsync	Real-time status indicating the frame synchronization state machine is not in sync on Lane N
LNK.StatLane.InNlnrealgn	Latched status set when a lane realignment occurs on Lane N
LNK.StatLane.InNfrrealgn	Latched status set when a frame realignment occurs on Lane N
LNK.StatLane.InNuk	Latched status set when an unexpected /K/ character is received at an unexpected position while code group synchronization is established on Lane N
LNK.StatLane.InNctrl	Latched status set when an unexpected control character other than /K/ is received when not expected on Lane N
LNK.StatLane.InNdisp	Latched status set when a disparity error is detected on Lane N
LNK.StatLane.InNnit	Latched status set when a NIT error is detected on Lane N
LNK.StatLane.InNcgs	Latched status set when code group synchronization state-machine is out of sync on Lane N
LNK.StatFIFO.InNfafail	Latched status set when dynamic FIFO adjustment fails due to not enough FIFO space on Lane N
LNK.StatFIFO.InNempty	Latched status set when the FIFO goes empty on Lane N
LNK.StatFIFO.InNfull	Latched status set when the FIFO goes full on Lane N
LNK.StatILAS.InNkerr	Latched status set when a /K/ character is received at the current CGS boundary while in frame sync on Lane N
LNK.StatILAS.InNrprbs	Latched status set when the SerDes interface PRBS monitor detected an error on Lane N
LNK.StatILAS.InNkrvc	Latched status set when a non-/K/ character is detected on Lane N
LNK.StatILAS.InNfchkerr	Latched status set when an ILA sequence FCHK error is detected on Lane N
LNK.StatILAS.InNlcfgerr	Latched status set when an ILA sequence lane configuration error is detected on Lane N
LNK.StatILAS.InNilaerr	Latched status set when an ILA sequence decode (/R/, /Q/, /A/ character) error is detected on Lane N
LNK.StatILA.nsync	Real-time status indicating ILA synchronization has not been achieved
LNK.StatILA.syncn_det	Latched status set on a resync request until a SYSREF pulse is detected
LNK.StatILA.sysref_ndet	Real-time SYSREF detection status set until first SYSREF detected
LNK.StatILA.fail	Latched status set when ILA failure due to not enough FIFO depth or when ILA is based on lanes that are not ready with data
LNK.StatLink.prbs_c2err	Latched status set when Converter 2 (Q-sample) PRBS error is detected
LNK.StatLink.prbs_c1err	Latched status set when Converter 1 (I-sample) PRBS error is detected
LNK.StatLink.stp_c2err	Latched status set when Converter 2 (Q-sample) short test pattern error is detected
LNK.StatLink.stp_c1err	Latched status set when Converter 1 (I-sample) short test pattern error is detected

**Digital Control Pins**

The MAX5871 contains two 1.8V CMOS logic digital control pins, RESETB and MUTE. The device is placed in a reset state when RESETB is low. This control line is level sensitive. On power-up, RESETB should remain low until all supply voltages have stabilized.

The MUTE pin defines when the device enters the mute mode. A high logic level places the device in mute mode while a low state establishes normal operation. In mute mode, the DAC digital input is set to midscale. The main purpose of mute is to eliminate any transmit power during the receive time of a TDMA system. In addition, there is a mute configuration programmed through the serial inter-

face that enables the mute mode internally regardless of the state of the MUTE pin. A duplication of the interrupt mask registers as Mute Enable registers generate the internal mute signal. Table 2 shows all the status register bits that can be enabled to generate internal mute. The internal control state of the converter is preserved while the MAX5871 is in the MUTE state.

**Frequency Planning**

Using a DAC to generate communications transmit signals requires careful consideration of aliased harmonics and internally generated divided clocks. Figure 22 shows an example of two modulated signals transmitted at 1.8GHz and 2.1GHz. The second harmonic (HD2) and

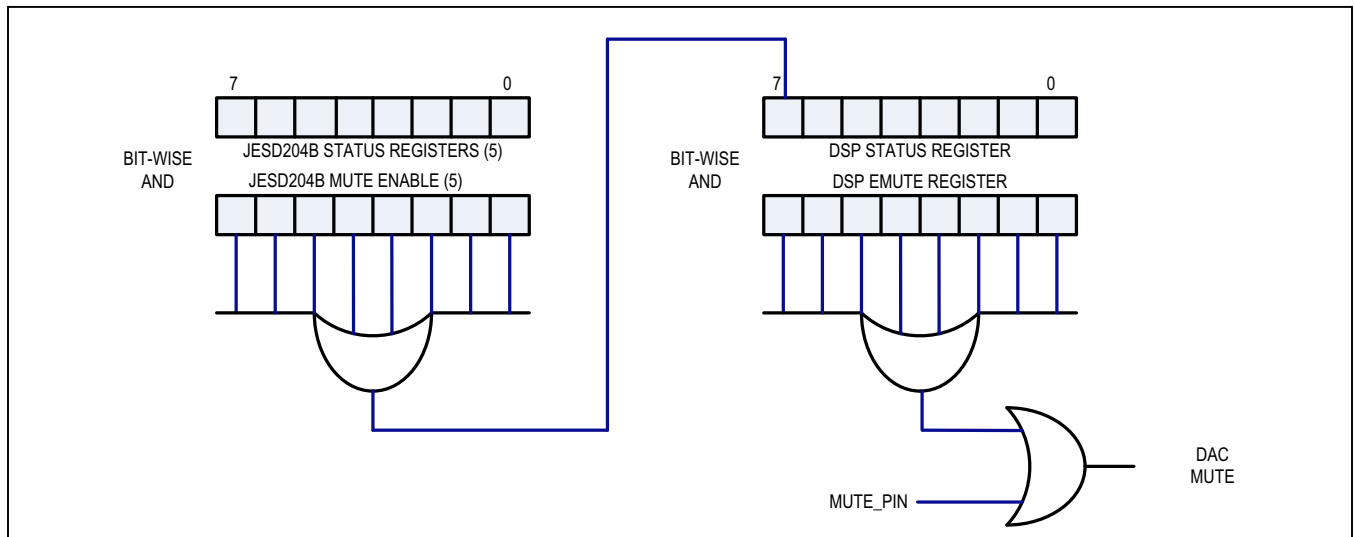

Figure 21. MAX5871 DAC Mute Generation

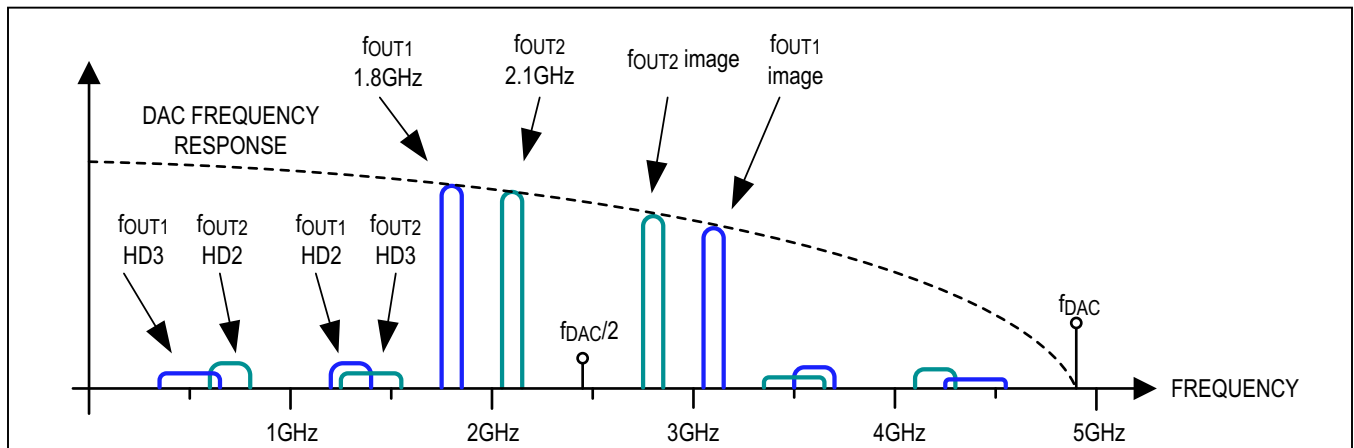

Figure 22. Example of Multiband Transmission and Dominant Harmonic Locations

third harmonic (HD3) of the signal are aliased close to the transmitted signal due to the DAC sampling rate.

The MAX5871 features a high-performance DAC core and many of the spurs and harmonics are suppressed. However, care must be taken to select the DAC sample rate such that the location of the dominant harmonics, such as HD2 and HD3, do not fall into the band of interest. If the board is not carefully designed to isolate the digital and analog portions, the input data may cause spurs to appear at the DAC output. The MAX5871 offers many interpolation settings for upconverting the input data such that a proper update rate can be chosen. For frequency planning, determine the input sample (or data) rate for the DAC and choose the DAC update rate such that the dominant harmonics are aliased outside of the band of interest. Next choose an interpolation rate closest to the DAC update rate divided by the input sample rate. Once the interpolation rate is determined, recalculate the exact DAC update rate, thereby determining the frequency of the DAC clock input. For new DAC update rate, reverify that the spur or harmonics are within spurious emission requirements.

**Signal Bandwidth**

The MAX5871 can generate a maximum I/Q complex signal bandwidth of 600.15MHz when operating  $f_{DAC} = 5898.24\text{MSPS}$  and 8x interpolation (or  $f_{DAC}$  and interpolation setting combinations with the maximum input sample rate of 737.28MHz) for output frequencies ranging from DC to Nyquist.

The actual signal bandwidth is dependent on the input sample rate ( $f_{S\_IN}$ ), or the DAC update rate ( $f_{DAC}$ ) divided by the interpolation setting (R), and the interpolation filter passband width (PBW = 0.407, expressed as a percentage of the input sample rate). The I/Q complex DAC signal bandwidth is calculated as:

$$\text{DAC Signal Bandwidth} = 2 \times (f_{DAC}/R) \times (\text{PBW})$$

The complex I/Q signals are converted to a real signal using a digital quadrature modulator and quadrature NCO. The real bandwidth is centered around the NCO frequency.

**Complex Modulator and NCO**

The device includes a complex modulator comprised of a complex NCO driving two multipliers followed by an adder (Figure 23). The complex modulator produces the result:

$$I(n) \times \text{COS}(\omega n) - Q(n) \times \text{SIN}(\omega n)$$

where I and Q are filtered and interpolated versions of the input I-data and Q-data.

The complex NCO employs a 33-bit phase accumulator to provide a programmed signal frequency up to  $f_{DAC}/2$ . The DAC sample rate,  $f_{DAC}$ , must be an integer multiple of a 30.72MHz reference frequency. The resolution of the MAX5871 can be programmed at 1Hz/10Hz/100Hz/1kHz/10kHz for a range of DAC clock frequency options. The user needs to program the following three parameters for the NCO, frequency control word (FCW), numerator frequency word (NFW), and denominator frequency word (DFW).

The NCO resolution ( $f_{STEP}$ ) is defined as:

$$f_{STEP} = \frac{f_{DAC}}{M \times 3 \times 2^{10} \times 10^N}$$

where  $f_{DAC} = M \times \text{reference frequency}$ . For example, if the reference frequency is 30.72MHz, use  $M = 192$  for a DAC clock frequency ( $f_{DAC}$ ) of 5898.24MSPS.  $N = 0-4$  sets the NCO resolution to 10kHz to 1Hz, respectively. The values of M and N are only used to calculate the FCW, NFW, and DFW that are required to program the required signal frequency.

To program the required output frequency ( $f_{OUT}$ ) of the DAC, the user needs to follow these steps:

- 1) Convert  $f_{OUT}$  into an integer number, mapping it on to the desired frequency resolution scale ( $f_r$ ) that depends on the value of N, using the equation:

$$f_r = f_{sig} \times 10^{n-4}$$

where  $f_{OUT}$  is in Hz.

- 2) The frequency control word parameters can be calculated using the following equation:

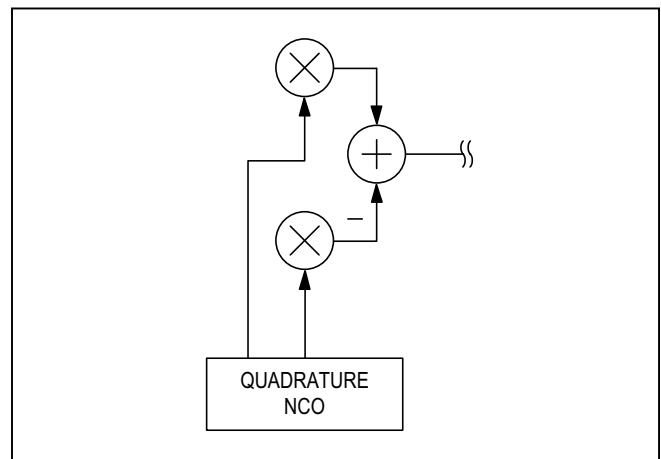

Figure 23. Complex NCO and Modulator

$$FCW = \frac{2^{33} \times f_r}{M \times 3 \times 2^{10} \times 10^N}$$

3) The previous calculation results in a rational value (FCW\_full) of the frequency control word. Only the quotient portion is set as the FCW. The remainder fractional value is converted into two integer rational numbers by removing the common integer multiplication factor between them. The numerator of this ratio is set as NFW and the denominator as DFW. Thus:

$$FCW\_full = FCW + \frac{NFW}{DFW}$$

FCW (32-bit), NFW (18-bit), and DFW (19-bit), control words are programmed via the SPI bus. If the above calculation results into an integer number then NFW=DFW=0 should be set:

$$FCW\_full = 2^{33} \times \frac{F_{NCO}}{F_{DAC}} = FCW + \frac{NFW}{DFW}$$

FCW\_full = full resolution of rational number to be programmed

FCW = integer part of the FCW\_full

NFW = numerator of the fractional part of FCW\_full

DFW = denominator of the fractional part of FCW\_full

The NCO block diagram is shown in Figure 24.

**When calculating FCW, NFW, and DFW, use long format (more precision) in Matlab code.**

For example, take M = 163 for f<sub>DAC</sub> = 163 x 30.72MHz = 5007.36MHz.

Case 1 select f<sub>NCO</sub> = 1796.769375MHz

$$FCW\_full = 2^{33} \times \frac{F_{NCO}}{F_{DAC}} = 2^{33} \times \frac{1796.769375MHz}{5007.36MHz} = 3082289152.000000$$

Therefore, FCW = 3082289152, NFW = 0, DFW = 0.

Case 2 select f<sub>NCO</sub> = 1796.875MHz

$$FCW\_full = 2^{33} \times \frac{F_{NCO}}{F_{DAC}} = 2^{33} \times \frac{1796.875MHz}{5007.36MHz} = 3082470347.64826000000$$

Therefore, FCW = 3082470347, NFW/DFW = 317/489 ~ 0.64826000000.

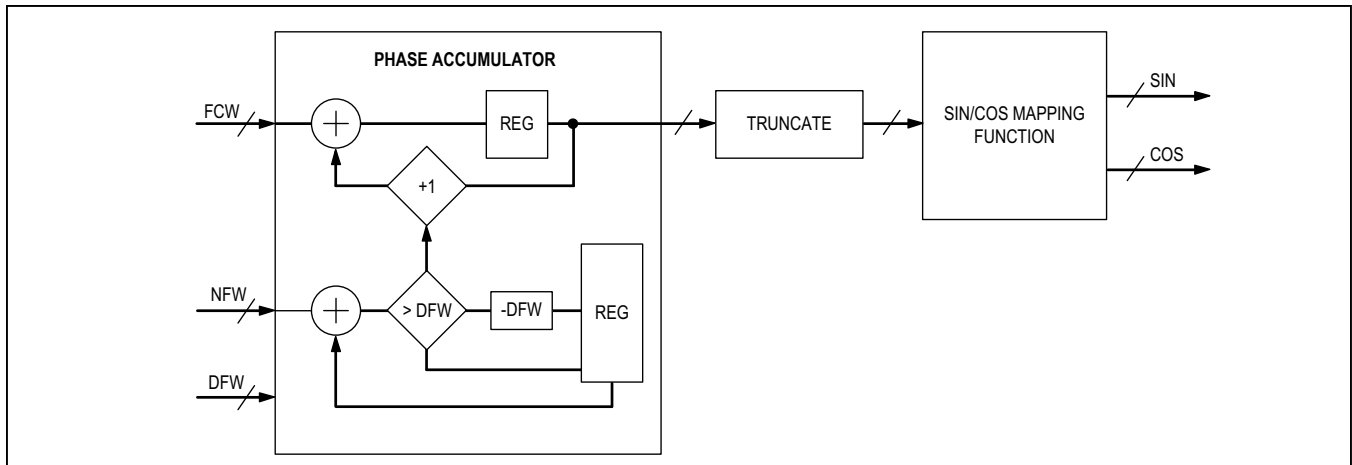

Figure 24. NCO Block Diagram



The following is a simple Matlab code for calculating FCW, NFW, and DFW:

```

% Find out MAX5871 NCO values
format long

% Define DAC clock frequency M=1-200
M = 163

Fdac = 30.72e6*M

% Define desired NCO frequency
Fnco = 1796.769375e6;

FCW_full = 2^33*Fnco/Fdac;

% Calculate FCW, NFW and DFWa
FCW = floor(FCW_full)
rats(FCW_full-FCW)
% END
    
```

**Analog Interface**

**Reference Interface**

The device operates with either the on-chip 1.2V band-gap reference or an external reference voltage source as shown in Figures 25a and 25b. REFIO serves as the input for an external, low-impedance reference source, or as the reference output when the internal reference is used. REFIO must be decoupled to DACREF with a 1µF capacitor when using the internal reference. REFIO must be buffered with an external amplifier if heavier loading is required, due to the 10kΩ series resistance.

The reference circuit employs a control amplifier designed to regulate the full-scale, differential output current, I<sub>OUTFS</sub>. The output current is calculated as follows:

$$I_{OUTFS} = 32 \times I_{REF}$$

where I<sub>REF</sub> is the reference output current (I<sub>REF</sub> = V<sub>REFIO</sub>/R<sub>SET</sub>) and I<sub>OUTFS</sub> is the full-scale output current of the DAC. Using the 1.2V (typical) internal reference and R<sub>SET</sub> of 1.28kΩ results in a full-scale output current of 30mA. In general, the dynamic performance of the DAC improves with increasing full-scale current.

**Analog Output**

The device is a differential current-steering DAC with built-in output termination resistors. The outputs are terminated to AVDD2 providing a 50Ω differential output resistance. In addition to the signal current, a constant current sink (I<sub>FIX</sub>) equal to one half I<sub>OUTFS</sub> is connected to each differential DAC output. N = 14 and is the number of bits of resolution of the DAC core. Figure 26 shows an equivalent circuit for the internal output structure of the device. The circuit has some resistive, capacitive and inductive elements. These elements have been minimized by design in order to achieve the highest possible output bandwidth (2600MHz typical).

In addition, the device requires a differential external termination (i.e. double termination). This external termination can be accomplished with a differential 50Ω load or a single-ended 50Ω load interfaced through a transformer. RF chokes to the AVDD2 supply should be used with the transformer coupled output. A typical transformer coupled configuration for high-frequency operation is shown in Figure 26.

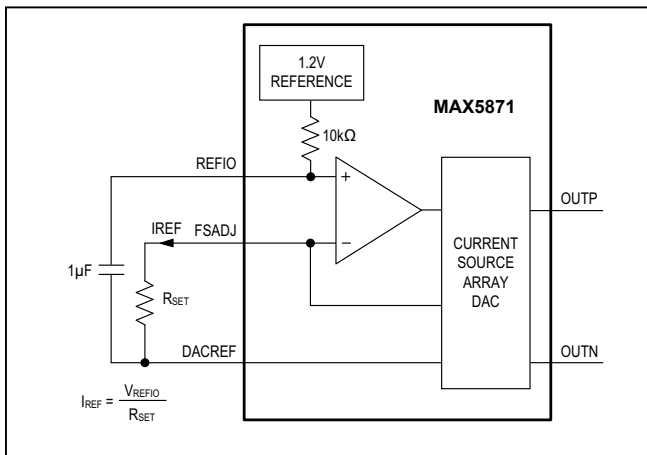

Figure 25a. Reference Architecture, Internal Reference Configuration

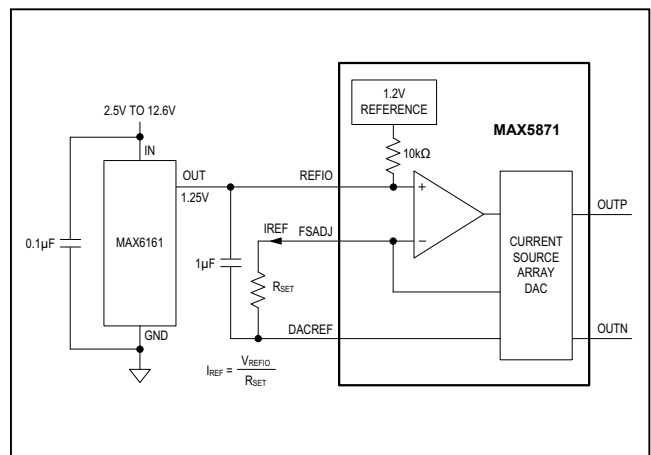

Figure 25b. Reference Architecture, External Reference Configuration

For applications where the DC information is important, the output configuration in Figure 27 can be used. 25Ω resistors to AVDD2 are required for DC coupling. The DC configuration will lower the output common-mode which may reduce performance slightly. The device is not compatible with an unterminated output when using the upper portion of the full-scale current range. Lowering the full-scale current to 20mA or less may allow use of the outputs without external terminations, though performance will be impacted in this configuration.

**Clock Interface**

The MAX5871 DAC contains a differential high frequency clock input (CLKP/CLKN) and an optional (bypassable) internal clock multiplying PLL to ease clock distribution. When the PLL is bypassed, the DAC is updated on the rising edge of (CLKP/CLKN) at maximum frequency of 5898.24MHz. See the *DAC Clock PLL* section for operation with PLL enabled.

The high-frequency clock should be a balanced fully differential signal with a 50%, or near 50%, duty cycle. The clock input has internal (on-chip) 100Ω differential termination. The clock inputs requires a minimum of 0dBm

input power. The clock inputs must be AC-coupled to the clock source as they are self-biased internally.

**DAC Clock PLL**

The MAX5871 differential high frequency clock input (CLKP/CLKN) also accepts an external reference clock signal that can be multiplied internally by a phase-locked-loop (PLL). The PLL includes user-programmable multiplication factors which provide flexibility in the reference clock selection. Figure 28 shows the functional block diagram of the PLL.

The reference input signal is divided by 1, 2, 4, or 8 under user control before being applied to the phase/frequency detector (PFD). The VCO output is divided by a programmable divide by 16/20/24/28 divider and fed back to the PFD. In addition to the programmable reference divider and programmable VCO divider, there is an optional output divide by 2, before the clock signal is supplied to the RF DAC.

Table 3 summarizes frequency multiplication factors between an external reference clock and DACCLK for various PLL settings.

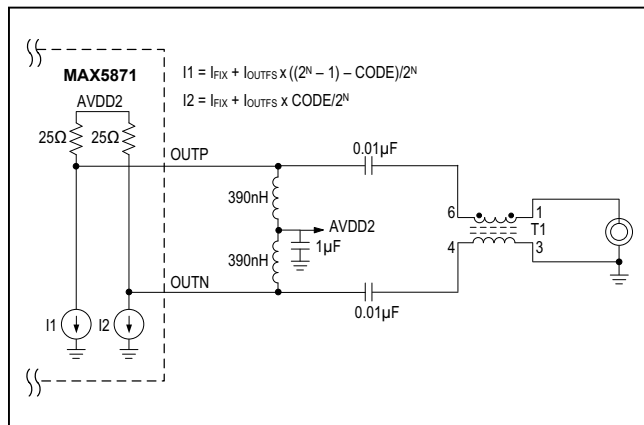

Figure 26. Typical DAC Output Configuration

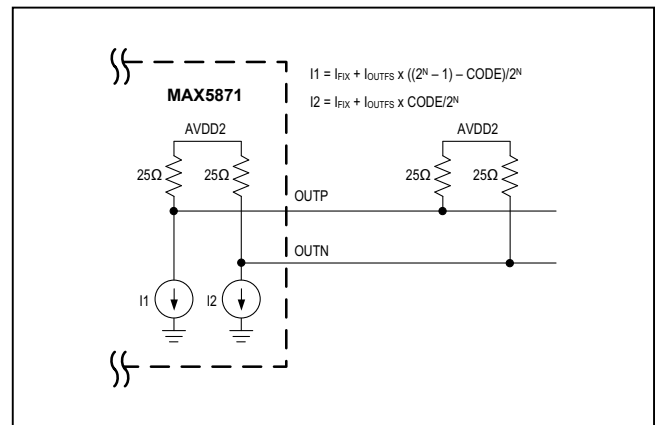

Figure 27. Output Configuration for Low-Frequency Operation

**Table 3. PLL Configuration Settings and Overall Multiplication Factor**

REFERENCE DIVIDE-SETTING (N)	FEEDBACK DIVIDE-SETTING (M)	POST DIVIDE-SETTING	VCO MULTIPLICATION FACTOR	OVERALL FREQUENCY MULTIPLICATION FACTOR
2	16	1	8	8
2	20	1	10	10
2	24	1	12	12
2	28	1	14	14
2	16	2	8	4
2	20	2	10	5
2	24	2	12	6
2	28	2	14	7
4	16	1	4	4
4	20	1	5	5
4	24	1	6	6
4	28	1	7	7
4	16	2	4	2
4	20	2	5	2.5
4	24	2	6	3
4	28	2	7	3.5
8	16	1	2	2
8	20	1	2.5	2.5
8	24	1	3.0	3
8	28	1	3.5	3.5
8	16	2	2	1
8	20	2	2.5	1.25
8	24	2	3.0	1.50
8	28	2	3.5	1.75

**VCO Band Select**

The VCO has two frequency ranges. The low range is 4.42368GHz to 4.9152GHz and the high range is 5.89824GHz to 6.1440GHz; however, the DAC sample rate is limited to 5.89824Gbps. The combination of reference frequency, reference and feedback divide values, and VCO band select must be chosen to operate the VCO within its allowed frequency range.

**Lock Detect**

The DAC clock PLL includes a lock detect indicator which can be read out of the SPI status register (DSP.StatPLL). Bit PLLST3 is set high when the PLL is locked and low when the PLL is unlocked.

**PLL External Components**

The DAC clock PLL requires external loop filter components. Figure 29 shows the schematic for the loop filter.

The loop filter components should be placed as close as possible to the MAX5871 to avoid noise coupling into the circuit. In addition to the loop filter, there is a bypass capacitor that must be placed very close to the MAX5871. The C1 nF and C2 pF capacitor values strongly depends on system PCB design and are unique for most designs (see the *Application Guidelines* section).

**Interpolation Filters**

The MAX5871 has powerful digital signal process capability with its built-in digital interpolation filters that can be configured with an interpolation ratio of 5x, 6x, 6.67x, 8x, 10x, 12x, 13.33x, 16x, 20x, 24x. Table 4 shows the digital filter coefficients of 8x and 10x interpolation ratios as examples. Figure 30 to Figure 39 show the frequency response of each of the interpolation ratio settings.

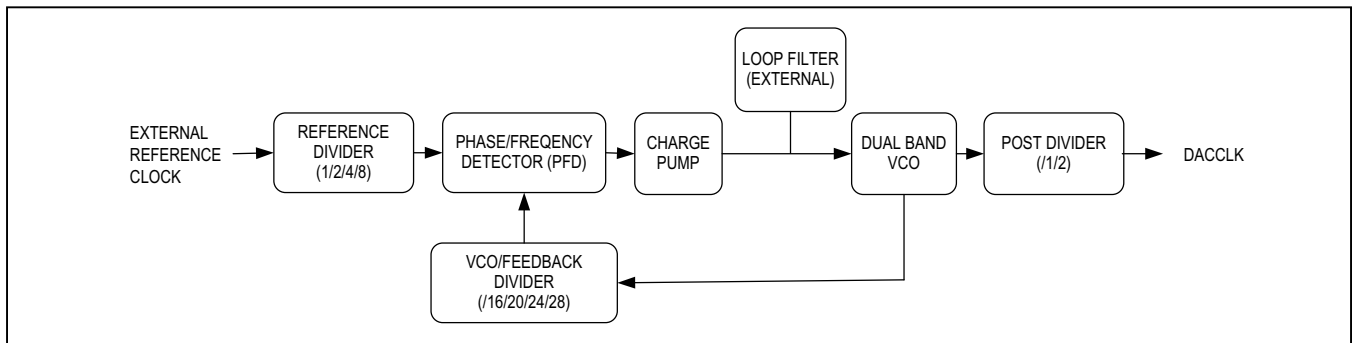

Figure 28. DAC Clock PLL Functional Block Diagram

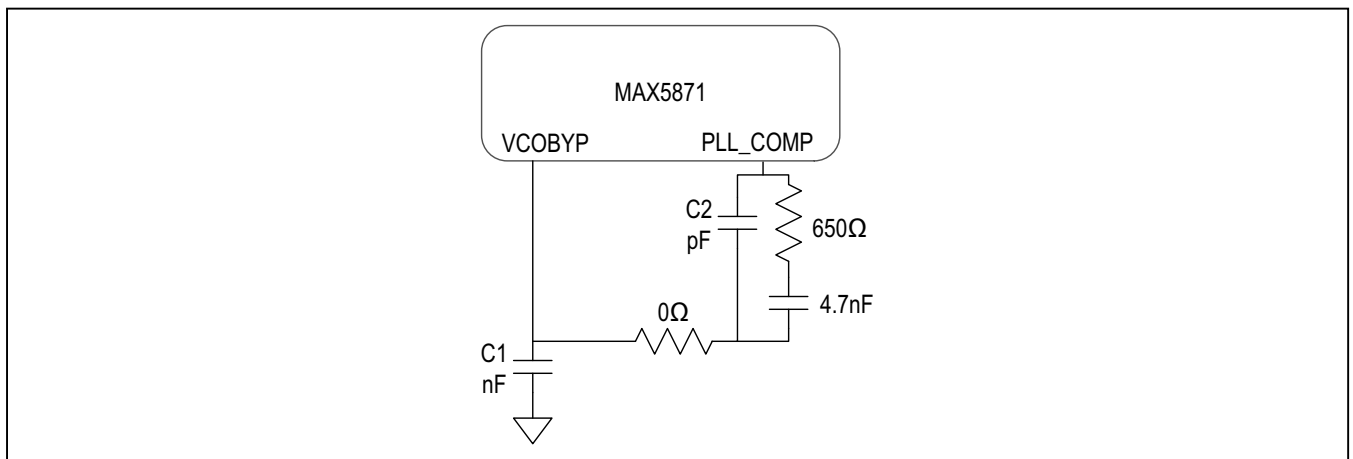

Figure 29. DAC Clock PLL External Components

Table 4. Digital Filter Coefficients for 8x and 10x Interpolation Ratios

TAPS	FILTER 8x	FILTER 10x	TAPS	FILTER 8x	FILTER 10x
1	0.0000000000000000	0.0000000000000000	171	0.04010009765625000	0.99548339843750000
2	0.00001525878906250	0.00001525878906250	172	0.05004882812500000	0.99548339843750000
3	0.00003051757812500	0.00003051757812500	173	0.05175781250000000	0.96273803710937500
4	0.00004577636718750	0.00003051757812500	174	0.04571533203125000	0.89920043945312500
5	0.00006103515625000	0.00004577636718750	175	0.03344726562500000	0.80863952636718700
6	0.00007629394531250	0.00006103515625000	176	0.01730346679687500	0.69641113281250000
7	0.00006103515625000	0.00007629394531250	177	0.00000000000000000	0.56901550292968700
8	0.00003051757812500	0.00007629394531250	178	-0.01580810546875000	0.43365478515625000
9	0.00000000000000000	0.00006103515625000	179	-0.02795410156250000	0.29772949218750000
10	-0.00003051757812500	0.00004577636718750	180	-0.03494262695312500	0.16838073730468700
11	-0.00006103515625000	0.00001525878906250	181	-0.03619384765625000	0.05197143554687500
12	-0.00013732910156250	0.00000000000000000	182	-0.03198242187500000	-0.04637145996093750
13	-0.00018310546875000	-0.00003051757812500	183	-0.02340698242187500	-0.12295532226562500
14	-0.00016784667968750	-0.00006103515625000	184	-0.01211547851562500	-0.17572021484375000
15	-0.00012207031250000	-0.00010681152343750	185	0.00000000000000000	-0.20431518554687500
16	-0.00006103515625000	-0.00015258789062500	186	0.01106262207031250	-0.21008300781250000
17	0.00000000000000000	-0.00018310546875000	187	0.01953125000000000	-0.19575500488281200
18	0.00012207031250000	-0.00016784667968750	188	0.02439880371093750	-0.16522216796875000
19	0.00024414062500000	-0.00012207031250000	189	0.02523803710937500	-0.12316894531250000
20	0.00033569335937500	-0.00007629394531250	190	0.02227783203125000	-0.07461547851562500
21	0.00039672851562500	-0.00001525878906250	191	0.01629638671875000	-0.02461242675781250
22	0.00039672851562500	0.00004577636718750	192	0.00842285156250000	0.02224731445312500
23	0.00033569335937500	0.00013732910156250	193	0.00000000000000000	0.06210327148437500
24	0.00019836425781250	0.00022888183593750	194	-0.00765991210937500	0.09211730957031250
25	0.00000000000000000	0.00030517578125000	195	-0.01348876953125000	0.11053466796875000
26	-0.00022888183593750	0.00036621093750000	196	-0.01683044433593750	0.11682128906250000
27	-0.00048828125000000	0.00038146972656250	197	-0.01739501953125000	0.11148071289062500
28	-0.00070190429687500	0.00038146972656250	198	-0.01530456542968750	0.09611511230468750
29	-0.00085449218750000	0.00033569335937500	199	-0.01113891601562500	0.07298278808593750
30	-0.00085449218750000	0.00022888183593750	200	-0.00573730468750000	0.04495239257812500
31	-0.00070190429687500	0.00009155273437500	201	0.00000000000000000	0.01504516601562500
32	-0.00041198730468750	-0.00009155273437500	202	0.00520324707031250	-0.01383972167968750
33	0.00000000000000000	-0.00028991699218750	203	0.00915527343750000	-0.03907775878906250
34	0.00048828125000000	-0.00048828125000000	204	0.01136779785156250	-0.05859375000000000
35	0.00097656250000000	-0.00067138671875000	205	0.01168823242187500	-0.07099914550781250
36	0.00138854980468750	-0.00080871582031250	206	0.01025390625000000	-0.07569885253906250
37	0.00161743164062500	-0.00085449218750000	207	0.00744628906250000	-0.07284545898437500
38	0.00161743164062500	-0.00082397460937500	208	0.00381469726562500	-0.06326293945312500
39	0.00134277343750000	-0.00070190429687500	209	0.00000000000000000	-0.04837036132812500
40	0.00077819824218750	-0.00047302246093750	210	-0.00343322753906250	-0.02996826171875000
41	0.00000000000000000	-0.00016784667968750	211	-0.00601196289062500	-0.01005554199218750

**Table 4. Digital Filter Coefficients for 8x and 10x Interpolation Ratios (continued)**

TAPS	FILTER 8x	FILTER 10x	TAPS	FILTER 8x	FILTER 10x
42	-0.00090026855468750	0.00019836425781250	212	-0.00744628906250000	0.00935363769531250
43	-0.00177001953125000	0.00061035156250000	213	-0.00762939453125000	0.02648925781250000
44	-0.00247192382812500	0.00099182128906250	214	-0.00666809082031250	0.03987121582031250
45	-0.00286865234375000	0.00132751464843750	215	-0.00482177734375000	0.04847717285156250
46	-0.00283813476562500	0.00155639648437500	216	-0.00247192382812500	0.05186462402343750
47	-0.00231933593750000	0.00164794921875000	217	0.00000000000000000	0.05007934570312500
48	-0.00134277343750000	0.00158691406250000	218	0.00219726562500000	0.04362487792968750
49	0.00000000000000000	0.00134277343750000	219	0.00381469726562500	0.03344726562500000
50	0.00152587890625000	0.00091552734375000	220	0.00469970703125000	0.02076721191406250
51	0.00299072265625000	0.00033569335937500	221	0.00479125976562500	0.00698852539062500
52	0.00415039062500000	-0.00036621093750000	222	0.00415039062500000	-0.00651550292968750
53	0.00479125976562500	-0.00109863281250000	223	0.00299072265625000	-0.01844787597656250
54	0.00469970703125000	-0.00177001953125000	224	0.00152587890625000	-0.02780151367187500
55	0.00381469726562500	-0.00234985351562500	225	0.00000000000000000	-0.03384399414062500
56	0.00219726562500000	-0.00274658203125000	226	-0.00134277343750000	-0.03625488281250000
57	0.00000000000000000	-0.00289916992187500	227	-0.00231933593750000	-0.03503417968750000
58	-0.00247192382812500	-0.00276184082031250	228	-0.00283813476562500	-0.03053283691406250
59	-0.00482177734375000	-0.00231933593750000	229	-0.00286865234375000	-0.02340698242187500
60	-0.00666809082031250	-0.00157165527343750	230	-0.00247192382812500	-0.01452636718750000
61	-0.00762939453125000	-0.00056457519531250	231	-0.00177001953125000	-0.00488281250000000
62	-0.00744628906250000	0.00061035156250000	232	-0.00090026855468750	0.00454711914062500
63	-0.00601196289062500	0.00184631347656250	233	0.00000000000000000	0.01289367675781250
64	-0.00343322753906250	0.00300598144531250	234	0.00077819824218750	0.01942443847656250
65	0.00000000000000000	0.00396728515625000	235	0.00134277343750000	0.02363586425781250
66	0.00381469726562500	0.00460815429687500	236	0.00161743164062500	0.02529907226562500
67	0.00744628906250000	0.00483703613281250	237	0.00161743164062500	0.02441406250000000
68	0.01025390625000000	0.00457763671875000	238	0.00138854980468750	0.02125549316406250
69	0.01168823242187500	0.00378417968750000	239	0.00097656250000000	0.01628112792968750
70	0.01136779785156250	0.00253295898437500	240	0.00048828125000000	0.01010131835937500
71	0.00915527343750000	0.00088500976562500	241	0.00000000000000000	0.00340270996093750
72	0.00520324707031250	-0.00102233886718750	242	-0.00041198730468750	-0.00314331054687500
73	0.00000000000000000	-0.00299072265625000	243	-0.00070190429687500	-0.00891113281250000
74	-0.00573730468750000	-0.00483703613281250	244	-0.00085449218750000	-0.01341247558593750
75	-0.01113891601562500	-0.00636291503906250	245	-0.00085449218750000	-0.01632690429687500
76	-0.01530456542968750	-0.00736999511718750	246	-0.00070190429687500	-0.01744079589843750
77	-0.01739501953125000	-0.00769042968750000	247	-0.00048828125000000	-0.01679992675781250
78	-0.01683044433593750	-0.00723266601562500	248	-0.00022888183593750	-0.01458740234375000
79	-0.01348876953125000	-0.00598144531250000	249	0.00000000000000000	-0.01113891601562500
80	-0.00765991210937500	-0.00398254394531250	250	0.00019836425781250	-0.00689697265625000

**Table 4. Digital Filter Coefficients for 8x and 10x Interpolation Ratios (continued)**

TAPS	FILTER 8x	FILTER 10x	TAPS	FILTER 8x	FILTER 10x
81	0.0000000000000000	-0.00141906738281250	251	0.00033569335937500	-0.00231933593750000
82	0.00842285156250000	0.00152587890625000	252	0.00039672851562500	0.00215148925781250
83	0.01629638671875000	0.00459289550781250	253	0.00039672851562500	0.00607299804687500
84	0.02227783203125000	0.00746154785156250	254	0.00033569335937500	0.00909423828125000
85	0.02523803710937500	0.00978088378906250	255	0.00024414062500000	0.01103210449218750
86	0.02439880371093750	0.01127624511718750	256	0.00012207031250000	0.01174926757812500
87	0.01953125000000000	0.01174926757812500	257	0.00000000000000000	0.01127624511718750
88	0.01106262207031250	0.01103210449218750	258	-0.00006103515625000	0.00976562500000000
89	0.00000000000000000	0.00910949707031250	259	-0.00012207031250000	0.00744628906250000
90	-0.01211547851562500	0.00607299804687500	260	-0.00016784667968750	0.00460815429687500
91	-0.02340698242187500	0.00215148925781250	261	-0.00018310546875000	0.00154113769531250
92	-0.03198242187500000	-0.00230407714843750	262	-0.00013732910156250	-0.00141906738281250
93	-0.03619384765625000	-0.00689697265625000	263	-0.00006103515625000	-0.00399780273437500
94	-0.03494262695312500	-0.01113891601562500	264	-0.00003051757812500	-0.00596618652343750
95	-0.02795410156250000	-0.01458740234375000	265	0.00000000000000000	-0.00720214843750000
96	-0.01580810546875000	-0.01679992675781250	266	0.00003051757812500	-0.00765991210937500
97	0.00000000000000000	-0.01744079589843750	267	0.00006103515625000	-0.00733947753906250
98	0.01730346679687500	-0.01631164550781250	268	0.00007629394531250	-0.00634765625000000
99	0.03344726562500000	-0.01341247558593750	269	0.00006103515625000	-0.00482177734375000
100	0.04571533203125000	-0.00889587402343750	270	0.00004577636718750	-0.00297546386718750
101	0.05175781250000000	-0.00312805175781250	271	0.00003051757812500	-0.00100708007812500
102	0.05004882812500000	0.00340270996093750	272	0.00001525878906250	0.00090026855468750
103	0.04010009765625000	0.01010131835937500	273	0.00000000000000000	0.00254821777343750
104	0.02273559570312500	0.01628112792968750	274		0.00379943847656250
105	0.00000000000000000	0.02127075195312500	275		0.00456237792968750
106	-0.02496337890625000	0.02442932128906250	276		0.00482177734375000
107	-0.04837036132812500	0.02529907226562500	277		0.00460815429687500
108	-0.06631469726562500	0.02363586425781250	278		0.00396728515625000
109	-0.07537841796875000	0.01942443847656250	279		0.00300598144531250
110	-0.07318115234375000	0.01289367675781250	280		0.00183105468750000
111	-0.05892944335937500	0.00454711914062500	281		0.00059509277343750
112	-0.03358459472656250	-0.00488281250000000	282		-0.00056457519531250
113	0.00000000000000000	-0.01452636718750000	283		-0.00155639648437500
114	0.03735351562500000	-0.02339172363281250	284		-0.00230407714843750
115	0.07293701171875000	-0.03050231933593750	285		-0.00274658203125000
116	0.10086059570312500	-0.03501892089843750	286		-0.00289916992187500
117	0.11575317382812500	-0.03625488281250000	287		-0.00274658203125000
118	0.11360168457031200	-0.03385925292968750	288		-0.00234985351562500
119	0.09259033203125000	-0.02781677246093750	289		-0.00177001953125000

**Table 4. Digital Filter Coefficients for 8x and 10x Interpolation Ratios (continued)**

TAPS	FILTER 8x	FILTER 10x	TAPS	FILTER 8x	FILTER 10x
120	0.05349731445312500	-0.01846313476562500	290		-0.00108337402343750
121	0.00000000000000000	-0.00651550292968750	291		-0.00036621093750000
122	-0.06158447265625000	0.00698852539062500	292		0.00032043457031250
123	-0.12277221679687500	0.02076721191406250	293		0.00091552734375000
124	-0.17385864257812500	0.03343200683593750	294		0.00134277343750000
125	-0.20507812500000000	0.04360961914062500	295		0.00158691406250000
126	-0.20782470703125000	0.05007934570312500	296		0.00164794921875000
127	-0.17584228515625000	0.05187988281250000	297		0.00154113769531250
128	-0.10620117187500000	0.04849243164062500	298		0.00131225585937500
129	0.00000000000000000	0.03987121582031250	299		0.00097656250000000
130	0.13760375976562500	0.02648925781250000	300		0.00059509277343750
131	0.29754638671875000	0.00936889648437500	301		0.00018310546875000
132	0.46774291992187500	-0.01005554199218750	302		-0.00018310546875000
133	0.63421630859375000	-0.02996826171875000	303		-0.00048828125000000
134	0.78253173828125000	-0.04838562011718750	304		-0.00070190429687500
135	0.89944458007812500	-0.06327819824218750	305		-0.00082397460937500
136	0.97422790527343700	-0.07286071777343750	306		-0.00086975097656250
137	0.99996948242187500	-0.07571411132812500	307		-0.00079345703125000
138	0.97422790527343700	-0.07101440429687500	308		-0.00067138671875000
139	0.89944458007812500	-0.05859375000000000	309		-0.00048828125000000
140	0.78253173828125000	-0.03907775878906250	310		-0.00028991699218750
141	0.63421630859375000	-0.01385498046875000	311		-0.00009155273437500
142	0.46774291992187500	0.01502990722656250	312		0.00009155273437500
143	0.29754638671875000	0.04498291015625000	313		0.00022888183593750
144	0.13760375976562500	0.07301330566406250	314		0.00032043457031250
145	0.00000000000000000	0.09613037109375000	315		0.00038146972656250
146	-0.10620117187500000	0.11149597167968700	316		0.00039672851562500
147	-0.17584228515625000	0.11682128906250000	317		0.00038146972656250
148	-0.20782470703125000	0.11056518554687500	318		0.00032043457031250
149	-0.20507812500000000	0.09213256835937500	319		0.00024414062500000
150	-0.17385864257812500	0.06210327148437500	320		0.00015258789062500
151	-0.12277221679687500	0.02223205566406250	321		0.00006103515625000
152	-0.06158447265625000	-0.02462768554687500	322		-0.00001525878906250
153	0.00000000000000000	-0.07464599609375000	323		-0.00009155273437500
154	0.05349731445312500	-0.12318420410156200	324		-0.00013732910156250
155	0.09259033203125000	-0.16522216796875000	325		-0.00016784667968750
156	0.11360168457031200	-0.19572448730468700	326		-0.00016784667968750
157	0.11575317382812500	-0.21005249023437500	327		-0.00015258789062500
158	0.10086059570312500	-0.20428466796875000	328		-0.00012207031250000



**Table 4. Digital Filter Coefficients for 8x and 10x Interpolation Ratios (continued)**

TAPS	FILTER 8x	FILTER 10x	TAPS	FILTER 8x	FILTER 10x
159	0.07293701171875000	-0.17565917968750000	329		-0.00007629394531250
160	0.03735351562500000	-0.12292480468750000	330		-0.00003051757812500
161	0.00000000000000000	-0.04637145996093750	331		0.00000000000000000
162	-0.03358459472656250	0.05195617675781250	332		0.00001525878906250
163	-0.05892944335937500	0.16836547851562500	333		0.00003051757812500
164	-0.07318115234375000	0.29769897460937500	334		0.00004577636718750
165	-0.07537841796875000	0.43363952636718700	335		0.00006103515625000
166	-0.06631469726562500	0.56903076171875000	336		0.00006103515625000
167	-0.04837036132812500	0.69642639160156200	337		0.00006103515625000
168	-0.02496337890625000	0.80863952636718700	338		0.00004577636718750
169	0.00000000000000000	0.89920043945312500	339		0.00003051757812500
170	0.02273559570312500	0.96275329589843700	340		0.00001525878906250

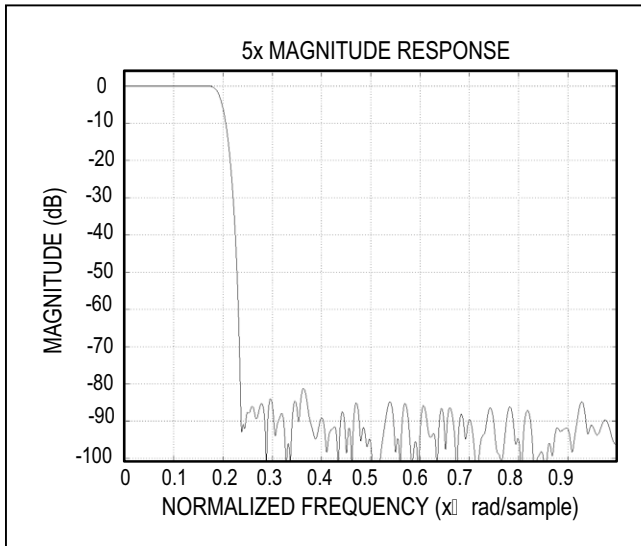

Figure 30. 5x Filter Baseband Frequency Response Normalized to DAC Output Update Rate

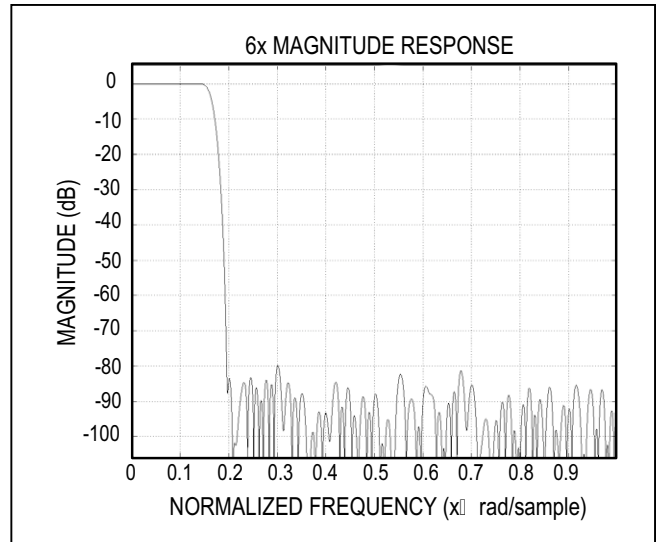

Figure 31. 6x Filter Baseband Frequency Response Normalized to DAC Output Update Rate

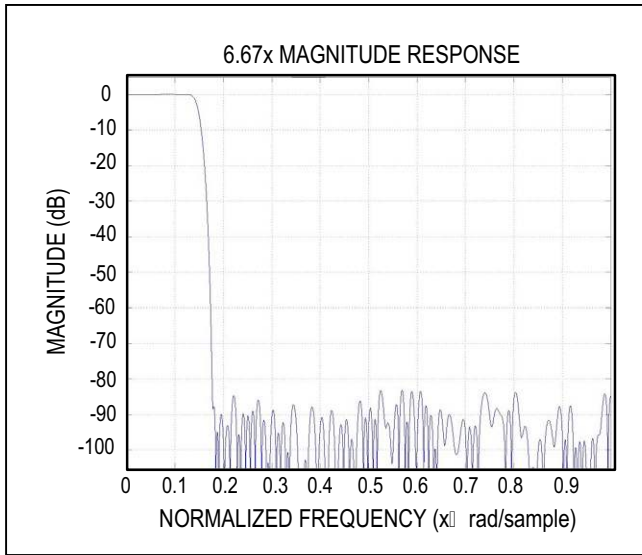

Figure 32. 6.67x Filter Baseband Frequency Response Normalized to DAC Output Update Rate

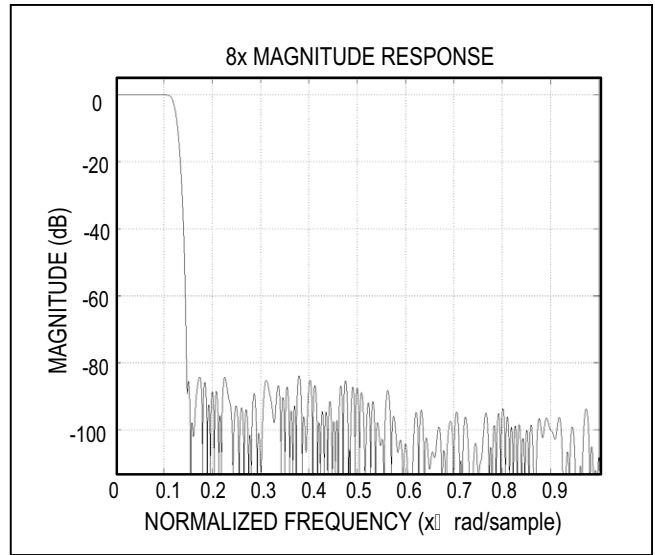

Figure 33. 8x Filter Baseband Frequency Response Normalized to DAC Output Update Rate

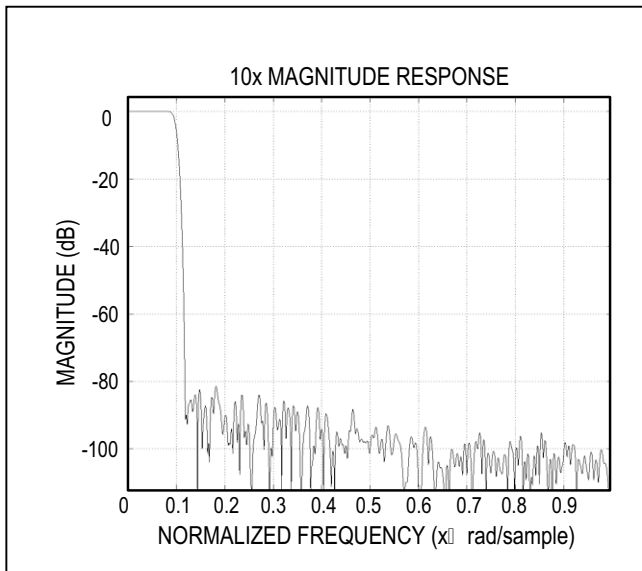

Figure 34. 10x Filter Baseband Frequency Response Normalized to DAC Output Update Rate

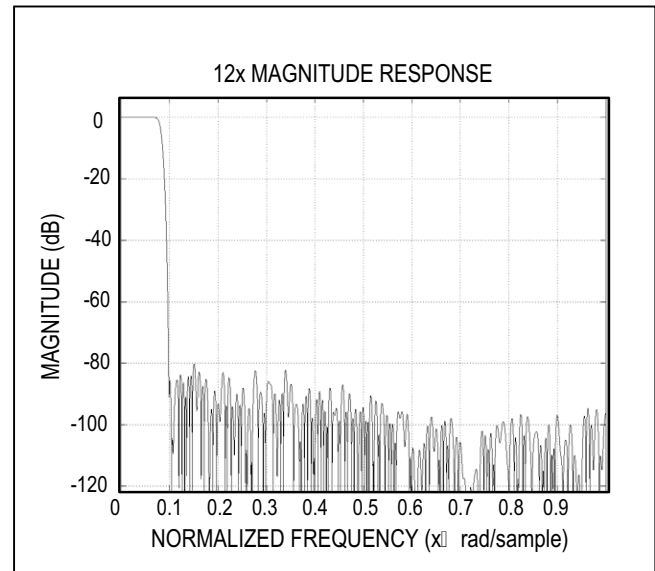

Figure 35. 12x Filter Baseband Frequency Response Normalized to DAC Output Update Rate

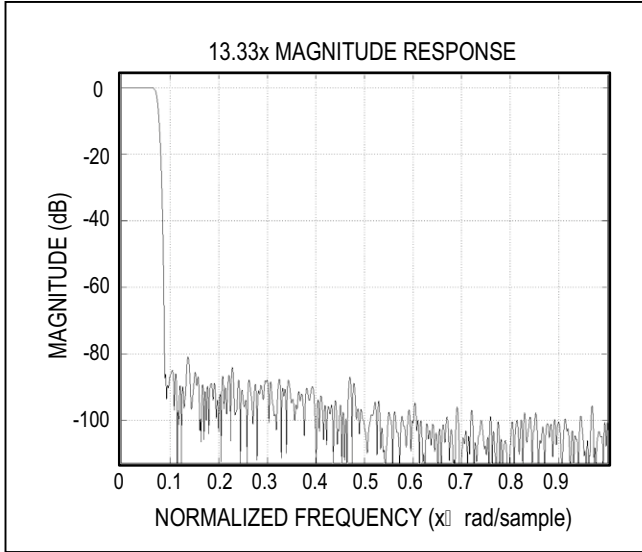

Figure 36. 13.33x Filter Baseband Frequency Response Normalized to DAC Output Update Rate

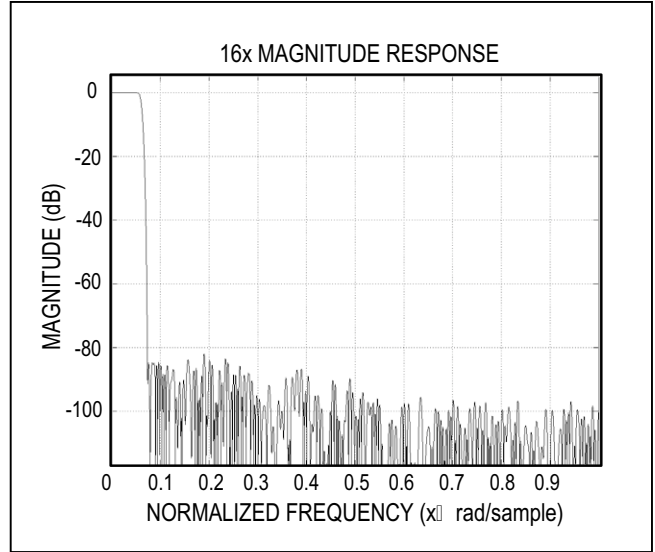

Figure 37. 16x Filter Baseband Frequency Response Normalized to DAC Output Update Rate

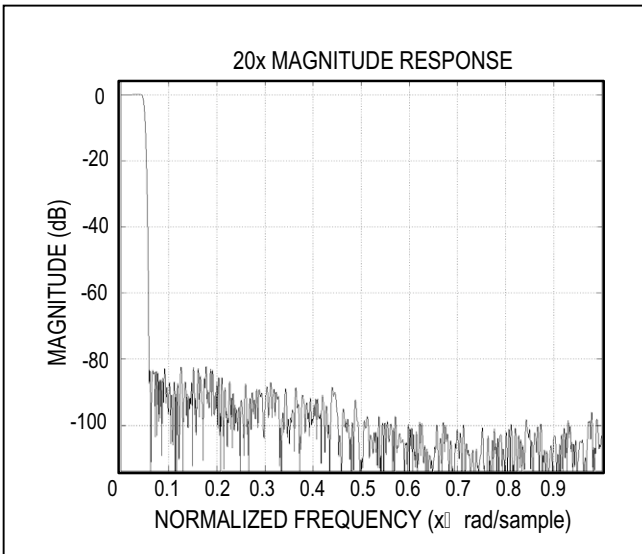

Figure 38. 20x Filter Baseband Frequency Response Normalized to DAC Output Update Rate

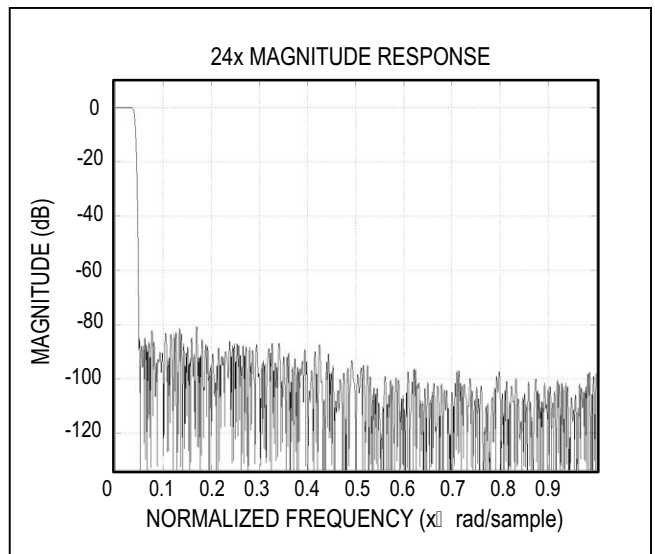

Figure 39. 24x Filter Baseband Frequency Response Normalized to DAC Output Update Rate

## Register Definition and Description

There are four banks of configuration registers in the MAX5871, which can be configured through SPI serial control interface.

### Configuration Register Banks

#### 1) Global Configuration Registers – GLB

This register bank configures SPI serial control interface, device information.

#### 2) DSP and DAC Configuration Registers – DSP

This register bank configures the MAX5871 chip operation, DSP engine, NCO, DAC operation, interruption and status, DAC PLL operation.

#### 3) Link Layer Configuration Registers for JESD204B – LNK

This register bank configures the JESD204B link layer on the serial data interface lanes, operation, and synchronization.

#### 4) SerDes Configuration Registers for JESD204B – SER

This register bank configures the JESD204B SerDes physical layer on the serial data interface lanes, operation, and synchronization.

### Register Bank Name, Bytes, Type, Address and Description

(Note: Do not write to registers with addresses not listed in the table below. Register addresses not listed are reserved for factory use.)

REGISTER NAME	BYTES	TYPE	ADDRESS DECIMAL	DESCRIPTION
<b>Global Configuration Registers–GLB</b>				
CfgIFA	1	RW	0	Configure Interface A
CfgIFB	1	RW	1	Configure Interface B
CfgDev	1	RW	2	Device Configuration
ChipType	1	R	3	Chip Type Status
VendorID	2	R	12	Vendor ID
CfgIFC	1	RW	15	Configure Interface C
CfgDACrate	1	RW	16	Configure DAC Update Rate
CfgCLKrate	1	RW	17	Configure CLKP/N Input Rate
CfgREGS	1	RW	18	Configure Register Options
<b>DSP and DAC Configuration Registers–DSP</b>				
CfgChipOM	1	RW	256	Configure Chip Operation Mode
CfgDSP	1	RW	257	Configure DSP Engine
CfgNCOF	4	RW	258	Configure NCO Frequency Control Word for DAC DSP
CfgNCON	3	RW	262	Configure NCO Frequency Control Word Numerator Word for DAC DSP
CfgNCOD	3	RW	265	Configure NCO Frequency Control Word Denominator Word for DAC DSP
CfgNCOU	1	RW	268	Configure NCO Update for DAC DSP
CfgNCOUS	3	RW	269	Configure NCO Step Size for DAC DSP
CfgPM	1	RW	272	Configure Power Monitor for DAC DSP
CfgPMT	1	RW	273	Configure Power Monitor Threshold for DAC DSP
CfgPMIC	6	RW	274	Configure Power Monitor Init Count 6x8=48 Bits for DAC DSP

REGISTER NAME	BYTES	TYPE	ADDRESS DECIMAL	DESCRIPTION
StatPM	2	R	280	Power Monitor Status for DAC DSP
CfgSync	1	RW	346	Configure Multi-DAC Synchronization for DAC DSP
CfgFIFO	1	RW	347	Configure Input FIFO for DAC
EMUTE	1	RW	354	Mute Enable Mask for DAC
EINT	1	RW	355	Interrupt Enable Mask for DAC DSP
STATUS	1	R	356	Status Register for DAC DSP
iFIFOLevel	1	R	357	Input FIFO Level for DAC
DieSN	3	R	358	MAX5871 RF DAC Serial Number. Total 8x3 = 24 Bits
CfgPLL	3	RW	384	Configure DAC PLL
StatPLL	2	R	387	DAC PLL Status
<b>Link Layer Configuration Registers for JESD204B-LNK</b>				
CfgSRst	1	RW	1024	Configure Soft Reset
CfgLnRst	1	RW	1025	Configure Lane Reset
CfgLinkSet	1	RW	1026	Configure Link Settings
CfgSYSREF	1	RW	1027	Configure SYSREF Signal
CfgSTHRSH	1	RW	1028	Configure SYSREF Threshold
CfgSIGN	1	RW	1029	Configure SYSREF Ignore Count
CfgSVLD	1	RW	1030	Configure SYSREF Valid Count
CfgSYNCN	1	RW	1031	Configure SYNCN pin options
CfgSAC	1	RW	1032	Configure SYNCN assert frame count
CfgSDC	1	RW	1033	Configure SYNCN deassert frame count
CfgLinkMLFS	1	RW	1034	Configure Link for M, L, F and S
CfgLinkK	1	RW	1035	Configure Link Multiframe Length
CfgBID	1	RW	1036	Configure Bank ID
CfgDID	1	RW	1037	Configure Device ID
CfgLID	4	RW	1038	Configure Lane N ID
CfgLinkSrc	1	RW	1042	Configure Link Signal Source
CfgClkInv	1	RW	1043	Configure Lane Clock Inversion
CfgLinkCtl	1	RW	1044	Configure Link Control
CfgBOff	2	RW	1045	Configure Manual Code Group Synch Bit Offsets
CfgRstCnt	1	RW	1047	Configure SYSREF Reset Counts
CfgILALck	1	RW	1048	Configure ILA Lock Configuration
CfgILAC	1	RW	1049	Configure ILA Control
CfgILAD	1	RW	1050	Configure ILA Delay Control
CfgILAM	4	RW	1051	Configure Lane N Manual ILA Delay
CfgILAmfs	2	RW	1055	Configure ILA Multiframe start
CfgILAsn	2	RW	1057	Configure ILA Sequence Number
CfgLerrM	2	RW	1059	Configure Error Mask for Reporting on SYNCN
CfgSerrM	2	RW	1061	Configure Error Mask for Resync Request on SYNCN
CfgMDS	2	RW	1063	Configure Multi-DAC Synchronization

REGISTER NAME	BYTES	TYPE	ADDRESS DECIMAL	DESCRIPTION
CfgINV	1	RW	1065	Configure Data Inversion
CfgLnSrc	2	RW	1066	Configure Lane Source
CfgLnEn	1	RW	1068	Configure Lane Enable
CfgFIFO	2	RW	1069	Configure FIFO Depths
CfgRepl	1	RW	1071	Configure Sample Replacement on NIT Error
CfgSamTest	1	RW	1072	Configure Sample Interface Test
CfgSTPc1s1	2	RW	1073	Configure Short Test Pattern for Converter 1, Sample 1
CfgSTPc1s2	2	RW	1075	Configure Short Test Pattern for Converter 1, Sample 2
CfgSTPc2s1	2	RW	1077	Configure Short Test Pattern for Converter 2, Sample 1
CfgSTPc2s2	2	RW	1079	Configure Short Test Pattern for Converter 2, Sample 2
CfgCnt	1	RW	1280	Configure Counter Settings
CfgCntSel	1	RW	1281	Configure Counter Selects
EIntLane	4	RW	1283	Lane N Interrupt Enable
EIntFIFO	4	RW	1287	Lane N FIFO Interrupt Enable
EIntLAS	4	RW	1291	Lane N ILA Sequence Interrupt Enable
EIntLA	1	RW	1295	Initial Lane Alignment Interrupt Enable
EIntLink	1	RW	1296	Link Interrupt Enable
EMuteLane	4	RW	1297	Lane N Mute Enable
EMuteFIFO	4	RW	1301	Lane N FIFO Mute Enable
EMuteLAS	4	RW	1305	Lane N ILA Sequence Mute Enable
EMuteLA	1	RW	1309	Initial Lane Alignment Mute Enable
EMuteLink	1	RW	1310	Link Mute Enable
StatLane	4	R	1408	Lane N Status
StatFIFO	4	R	1412	Lane N FIFO Status
StatLAS	4	R	1416	Lane N ILA Sequence Status
StatLA	1	R	1420	Initial Lane Alignment Status
StatLink	1	R	1421	Link Status
CntInvid	2	R	1422	Counter for Invalid Errors
CntDbg	2	R	1424	Counter for Lane Debug
<b>SERDES Configuration Registers for JESD204B-SER</b>				
CfgRst	1	RW	1536	Configure Reset for All Lanes
CfgRate	1	RW	1542	Configure Rate for All Lanes
CfgTrainLnN	4	RW	1543	Configure Training for Lane N
CfgMisc	1	RW	1547	Configure Miscellaneous for All Lanes
EIntLnN	4	RW	1600	SerDes Phy Logic Interrupt Enable for Lane N
EMuteLnN	4	RW	1604	SerDes Phy Logic DAC Mute Enable for Lane N
StatusLnN	4	R	1608	SerDes Phy Logic Status for Lane N
CfgCMU	8	RW	1792	Configure CMU

**Note:** In the following *Register Definition and Description* sections, register and register bit marked with asterisk "\*" indicates that it needs GLB.CfgIFC.Xfer writing a 1 to transfer the register content into active registers to take effect, when GLB.CfgREGS.ActSel = 1.

**Global Configuration Registers Definition and Description**

ADDRESS	BYTE	REGISTER NAME	DESCRIPTION							
0x0000	1	CfgIFA	Configure Interface A							
		Bit	7	6	5	4	3	2	1	0
		Name	SftRst	LSBF	AddIncr	4Wire	4Wire	AddIncr	LSBF	SftRst
		Default	0	0	0	0	0	0	0	0
		Definition	SftRst Writing a 1 to this bit resets all of the digital logic except address 0x0000, 0x0001, and SPI interface. This bit is self-clearing.							
			LSBF 0 = MSB first for SPI interface input control/data and output data 1 = LSB first for SPI interface input control/data and output data							
			AddIncr 0 = Decrement address for SPI streaming mode 1 = Increment address for SPI streaming mode							
			4Wire 0 = 3-Wire SPI mode, SDIO used for both input and output 1 = 4-Wire SPI mode, SDIO is input and SDO is output							
		Note	Bits[3:0] are mirrored in Bits[4:7], both low and high bits need to be written to the same value							
0x0001	1	CfgIFB	Configure Interface B							
		Bit	7	6	5	4	3	2	1	0
		Name	StrmDis	Res	RdReg	Res	Reserved	X	X	Res
		Default	0	0	0	0	0	0	0	0
		Definition	StrmDis 0 = SPI streaming mode is enabled 1 = SPI streaming mode is disabled and continued CSB assertion forces instruction-data format							
			RdReg 0 = Register read back from active registers 1 = Register read back from buffer registers For fields that are not implemented with active/buffer registers, this bit has no effect.							
0x0002	1	CfgDev	Device Configuration							
		Bit	7	6	5	4	3	2	1	0
		Name	Res	Res	Res	Res	Res	CDrst*	PDM1	PDM0
		Default	0	0	0	0	0	0	0	0
		Definition	PDM[1:0] 00 = Normal operation mode 01 = Reserved 10 = Reserved 11 = Sleep mode with lowest power dissipation with chip inactivity except SPI interface CDrst* 0 = Clock Divider is not reset 1 = Clock Divider is reset							

**Global Configuration Registers Definition and Description (continued)**

ADDRESS	BYTE	REGISTER NAME	DESCRIPTION							
0x0003	1	ChipType	Chip Type Status							
		Bit	7	6	5	4	3	2	1	0
		Name	X	X	X	X	Type3	Type2	Type1	Type0
		Default	0	0	0	0	0	1	0	0
		Definition	Type[3:0] Read-only field indicating high-speed DAC							
0x000C	2	VendorID	Maxim Integrated ID							
		Bit	7	6	5	4	3	2	1	0
		Name	VID7	VID6	VID5	VID4	VID3	VID2	VID1	VID0
		Bit	15	14	13	12	11	10	9	8
		Name	VID15	VID14	VID13	VID12	VID11	VID10	VID9	VID8
		Default	16'h0B6A							
		Definition	Read-only Maxim Integrated ID							
0x000F	1	CfgIFC	Configure Interface C							
		Bit	7	6	5	4	3	2	1	0
		Name	X	X	X	X	X	X	X	Xfer
		Default	0	0	0	0	0	0	0	0
		Definition	Xfer Writing a 1 transfers the buffer registers to active registers. This bit is self-clearing. <b>Note:</b> After the internal configuration is complete, DSP.STATUS.TRDY status is set							
0x0010	1	CfgDACrate	Configure DAC Update Rate							
		Bit	7	6	5	4	3	2	1	0
		Name	X	X	X	X	Drate3	Drate2	Drate1	Drate0
		Default	0	0	0	0	1	0	1	0
		Definition	Drate[3:0] DAC rate 0000 = 2211.8MHz 0001 = 2457.6MHz 0010 = 2949.1MHz 0011 = 3072.0MHz 0100 = 3276.8MHz 0101 = 3686.4MHz 0110 = 3932.2MHz 0111 = 4096.0MHz 1000 = 4423.7MHz 1001 = 4915.2MHz 1010 = 5898.2MHz 1011 = 6144.0MHz 1100–1111 = Reserved							



**Global Configuration Registers Definition and Description (continued)**

ADDRESS	BYTE	REGISTER NAME	DESCRIPTION							
0x0011	1	CfgCLKrate	Configure CLKP/N Input Rate							
		Bit	7	6	5	4	3	2	1	0
		Name	X	X	X	X	Crate3	Crate2	Crate1	Crate0
		Default	0	0	0	0	1	1	1	0
		Definition	Crate[3:0] CLKP/N rate 0000 = 2211.8MHz 0001 = 2457.6MHz 0010 = 2949.1MHz 0011 = 3072.0MHz 0100 = 3276.8MHz 0101 = 3686.4MHz 0110 = 3932.2MHz 0111 = 4096.0MHz 1000 = 4423.7MHz 1001 = 4915.2MHz 1010 = 5898.2MHz 1011 = 6144.0MHz 1100 = 983.04MHz 1101 = 1228.8MHz 1110 = 1474.56MHz 1111 = Reserved							
0x0012	1	CfgREGS	Configure Register options							
		Bit	7	6	5	4	3	2	1	0
		Name	X	X	X	X	X	X	ActSel	IntCfg
		Default	0	0	0	0	0	0	0	0
		Definition	ActSel 0 = Buffer register output is used 1 = Active register output is used for registers that are updated with CfgIFC.Xfer bitIntCfg 0 = Internal register configuration is disabled 1 = When CfgIFC.Xfer bit is set, some JESD204B registers are configured internally. (After internal configuration is complete, the DSP.STATUS.TRDY latched status is set.) Contact the chip manufacturer for more details if this function is needed.							

**DSP and DAC Configuration Registers Definition and Description**

ADDRESS	BYTE	REGISTER NAME	DESCRIPTION							
0x0100	1	CfgChipOM	Configure Chip Operation Mode							
		Bit	7	6	5	4	3	2	1	0
		Name	Reserved2	RclkM1	RclkM0	INVQ*	Reserved1	Mute	Reserved0	DFMT*
		Default	0	0	0	0	0	1	0	0
		Definition	Reserved2 Reserved – Do not write							
			RclkM[1:0] 00 = RCLK output is DAC clock divided by (interpolation ratio x 1) 01 = RCLK output is DAC clock divided by (interpolation ratio x 2) 10 = RCLK output is DAC clock divided by (interpolation ratio x 4) 11 = Reserved							
			INVQ 0 = Disable DAC I-Q data Q being inverted to make I-Q (default) 1 = Enable DAC I-Q data Q being inverted to make I+Q							
			Reserved1 Reserved – Do not write							
			Mute 0 = DAC in normal mode 1 = Enable DAC mute							
			Reserved0 Reserved – Do not write							
			DFMT 0 = DAC Input data in two's complement format 1 = DAC Input data in offset binary format							

**DSP and DAC Configuration Registers Definition and Description (continued)**

ADDRESS	BYTE	REGISTER NAME	DESCRIPTION							
0x0101	1	CfgDSP	Configure DSP Engine							
		Bit	7	6	5	4	3	2	1	0
		Name	R3*	R2*	R1*	R0*	RstDSP	RstFIFO	NCOE*	NCOLD
		Default	0	0	0	0	0	0	0	0
		Definition	R[3:0] 1001 = DSP interpolation mode is 5x 1010 = DSP interpolation mode is 6x 1011 = DSP interpolation mode is 8x 0000 = DSP interpolation mode is 10x 1100 = DSP interpolation mode is 12x 1101 = DSP interpolation mode is 16x 1110 = DSP interpolation mode is 20x 1111 = DSP interpolation mode is 24x 0010 = DSP interpolation mode is 20/3x 0011 = DSP interpolation mode is 40/3x 0001, 0100 - 1000 = Reserved							
			RstDSP 0 = No reset 1 = Reset DSP (Input FIFO, interpolation filters, complex modulator and NCO)							
			RstFIFO 0 = No reset 1 = Reset input data FIFO							
			NCOE 0 = Disable Extended NCO mode for DAC 1 = Enable Extended NCO mode using the fractional NCO control words in CfgNCON and CfgNCOD							
			NCOLD Writing a 1 loads NCO frequency control words to the DSP, this bit is self-clearing The NCO frequency control words are also loaded when GLBL.CfgIFC.Xfer bit is set to 1							
0x0102	4	CfgNCOF*	Configure NCO Frequency Control Word for DSP							
		Bit	7	6	5	4	3	2	1	0
		Name	FCW7	FCW6	FCW5	FCW4	FCW3	FCW2	FCW1	FCW0
		Bit	15	14	13	12	11	10	9	8
		Name	FCW15	FCW14	FCW13	FCW12	FCW11	FCW10	FCW9	FCW8
		Bit	23	22	21	20	19	18	17	16
		Name	FCW23	FCW22	FCW21	FCW20	FCW19	FCW18	FCW17	FCW16
		Bit	31	30	29	28	27	26	25	24
		Name	FCW31	FCW30	FCW29	FCW28	FCW27	FCW26	FCW25	FCW24
		Default	0x00000000							
		Definition	FCW[31:0] NCO Frequency Control Word							

**DSP and DAC Configuration Registers Definition and Description (continued)**

ADDRESS	BYTE	REGISTER NAME	DESCRIPTION							
0x0106	3	CfgNCON*	Configure NCO Frequency Control Word Numerator Word for DSP							
		Bit	7	6	5	4	3	2	1	0
		Name	NFW7	NFW6	NFW5	NFW4	NFW3	NFW2	NFW1	NFW0
		Bit	15	14	13	12	11	10	9	8
		Name	NFW15	NFW14	NFW13	NFW12	NFW11	NFW10	NFW9	NFW8
		Bit	23	22	21	20	19	18	17	16
		Name	X	X	X	X	X	X	NFW17	NFW16
		Default	0x000000							
		Definition	NFW[17:0] Numerator word of the Extended NCO Frequency Control Word							
0x0109	3	CfgNCOD*	Configure NCO Frequency Control Word Denominator Word for DSP							
		Bit	7	6	5	4	3	2	1	0
		Name	DFW7	DFW6	DFW5	DFW4	DFW3	DFW2	DFW1	DFW0
		Bit	15	14	13	12	11	10	9	8
		Name	DFW15	DFW14	DFW13	DFW12	DFW11	DFW10	DFW9	DFW8
		Bit	23	22	21	20	19	18	17	16
		Name	X	X	X	X	X	DFW18	DFW17	DFW16
		Default	0x000000							
		Definition	DFW[18:0] Denominator word of the Extended NCO Frequency Control Word							
0x010C	1	CfgNCOU	Configure NCO Update for DSP							
		Bit	7	6	5	4	3	2	1	0
		Name	X	X	Reserved	Reserved	Reserved	Reserved	RLM1	Reserved
		Default	0	0	0	0	0	0	0	0
		Definition	RLM1 0 = Load immediately with no glitch control 1 = Use step increment/decrement mode for a slow change in NCO phase towards the new frequency							
0x010D	3	CfgNCOUS	Configure NCO Step Size for DSP							
		Bit	7	6	5	4	3	2	1	0
		Name	TIM7	TIM6	TIM5	TIM4	TIM3	TIM2	TIM1	TIM0
		Bit	15	14	13	12	11	10	9	8
		Name	TIM15	TIM14	TIM13	TIM12	TIM11	TIM10	TIM9	TIM8
		Bit	23	22	21	20	19	18	17	16
		Name	TIM23	TIM22	TIM21	TIM20	TIM19	TIM18	TIM17	TIM16
		Default	0x000000							
		Definition	TIM[23:0] NCO Step Size in DAC Clock /8 clock cycles when CfgNCOU.RLM1=1							

**DSP and DAC Configuration Registers Definition and Description (continued)**

ADDRESS	BYTE	REGISTER NAME	DESCRIPTION							
0x0110	1	CfgPM	Configure Power Monitor for DSP							
		Bit	7	6	5	4	3	2	1	0
		Name	X	X	X	X	X	Start	Mode	Reset
		Default	0	0	0	0	0	0	0	0
		Definition	Start 0 = Power Monitor Stop 1 = Power Monitor Start							
			Mode 0 = Count samples below the threshold 1 = Count samples above the threshold							
			Reset Writing a 1 resets the power monitor count, this bit is self-clearing							
0x0111	1	CfgPMT	Configure Power Monitor Threshold for DSP							
		Bit	7	6	5	4	3	2	1	0
		Name	PMT7	PMT6	PMT5	PMT4	PMT3	PMT2	PMT1	PMT0
		Default	0	0	0	0	0	0	0	0
		Definition	PMT[7:0] Power Monitor Threshold							
0x0112	6	CfgPMIC	Configure Power Monitor Initial Count for DSP							
		Bit	7	6	5	4	3	2	1	0
		Name	PMIC7	PMIC6	PMIC5	PMIC4	PMIC3	PMIC2	PMIC1	PMIC0
		Bit	15	14	13	12	11	10	9	8
		Name	PMIC15	PMIC14	PMIC13	PMIC12	PMIC11	PMIC10	PMIC9	PMIC8
		Bit	23	22	21	20	19	18	17	16
		Name	PMIC23	PMIC22	PMIC21	PMIC20	PMIC19	PMIC18	PMIC17	PMIC16
		Bit	31	30	29	28	27	26	25	24
		Name	PMIC31	PMIC30	PMIC29	PMIC28	PMIC27	PMIC26	PMIC25	PMIC24
		Bit	39	38	37	36	35	34	33	32
		Name	PMIC39	PMIC38	PMIC37	PMIC36	PMIC35	PMIC34	PMIC33	PMIC32
		Bit	47	46	45	44	43	42	41	40
		Name	PMIC47	PMIC46	PMIC45	PMIC44	PMIC43	PMIC42	PMIC41	PMIC40
		Default	0x000000000000							
		Definition	PMIC[47:0] Power Monitor initial count							

**DSP and DAC Configuration Registers Definition and Description (continued)**

ADDRESS	BYTE	REGISTER NAME	DESCRIPTION							
0x0118	2	StatPM	Power Monitor Status for DSP							
		Bit	7	6	5	4	3	2	1	0
		Name	PMST7	PMST6	PMST5	PMST4	PMST3	PMST2	PMST1	PMST0
		Bit	15	14	13	12	11	10	9	8
		Name	PMDONE	X	X	X	PMST11	PMST10	PMST9	PMST8
		Default	12'h000							
		Definition	PMST[11:0] Power Monitor Status indicating the threshold crossing count PMDONE 1 = Power Monitor Status update done 0 = Power Monitor Status update in progress							
0x015A	1	CfgSYNC	Configure multiple-DAC synchronization for DSP							
		Bit	7	6	5	4	3	2	1	0
		Name	DSP_ASync*	ClkDiv_Sync*	iFIFO_Sync*	NCO_Sync*	X	Reserved	OIF_dinc	OIF_ddec
		Default	0	0	0	0	0	0	0	0
		Definition	DSP_ASync 0 = Disable Asynchronous SYSREF reset to the DSP 1 = Enable Asynchronous SYSREF reset to the DSP when there is no device cock to the JESD204B Link  ClkDiv_Sync When DSP_ASync = 0 0 = Disable synchronous SYSREF reset to the clock-divider block 1 = Enable synchronous SYSREF reset to the clock-divider block When DSP_ASync = 1 0 = Enable first asynchronous SYSREF reset to the clock-divider block 1 = Enable continuous asynchronous SYSREF reset to the clock-divider block  iFIFO_Sync 0 = Disable synchronous SYSREF reset to the input FIFO 1 = Enable synchronous SYSREF reset to the input FIFO  NCO_Sync 0 = Disable synchronous SYSREF reset to the NCO 1 = Enable synchronous SYSREF reset to the NCO  OIF_dinc Writing a 1 increases the DSP latency by one DAC clock cycle, this bit is self-clearing  OIF_ddec Writing a 1 decreases the DSP latency by one DAC clock cycle, this bit is self-clearing							

**DSP and DAC Configuration Registers Definition and Description (continued)**

ADDRESS	BYTE	REGISTER NAME	DESCRIPTION							
0x015B	1	CfgFIFO	Configure Input FIFO for DSP							
		Bit	7	6	5	4	3	2	1	0
		Name	RdPtrAdj3	RdPtrAdj2	RdPtrAdj1	RdPtrAdj0	Off	Dupl*	SwapIQ*	RevBitOrd*
		Default	0	0	0	0	0	0	0	0
		Definition	RdPtrAdj[3:0] 0 Adjust read pointer by adding this value to the free running read pointer							
			Off 0 = Input FIFO is not bypassed 1 = Input FIFO is bypassed							
			Dupl 0 = Do not duplicate I 1 = Duplicate I for Q							
			SwapIQ 0 = Normal I/Q Order 1 = Reverse I/Q Order							
			RevBitOrd 0 = Normal LSB/MSB Order 1 = Reverse LSB/MSB Order							
0x0162	1	EMUTE	Mute Enable Register for DAC							
		Bit	7	6	5	4	3	2	1	0
		Name	EM7	EM6	EM5	EM4	EM3	EM2	EM1	EM0
		Default	0	0	0	0	0	0	0	0
		Definition	EM[7:0] 0 = DAC Mute not enabled when the corresponding bit in STATUS register is set 1 = Enable DAC Mute when the corresponding bit in STATUS register is set							
0x0163	1	EINT	Interrupt Enable Register for DSP							
		Bit	7	6	5	4	3	2	1	0
		Name	EINT7	EINT6	EINT5	EINT4	EINT3	EINT2	EINT1	EINT0
		Default	0	0	0	0	0	1	0	0
		Definition	EINT[7:0] 0 = Interrupt not enabled when the corresponding bit in STATUS register is set 1 = Enable Interrupt when the corresponding bit in STATUS register is set							

**DSP and DAC Configuration Registers Definition and Description (continued)**

ADDRESS	BYTE	REGISTER NAME	DESCRIPTION							
0x0164	1	STATUS	Status Register for DAC DSP							
		Bit	7	6	5	4	3	2	1	0
		Name	JSDIM	JSDII	FCOL	F1A	F2A	TRDY	Reserved	PLLlck
		Default	0xXX							
		Definition	JSDIM 0 = JSDI Link layer Mute is not active 1 = JSDI Link layer Mute is active							
			JSDII 0 = JSDI Link layer Interrupt is not active 1 = JSDI Link layer Interrupt is active							
			FCOL 0 = Input FIFO Rd/Wr pointers are not in collision 1 = Input FIFO Rd/Wr pointers are in collision indicating FIFO underflow/overflow. This is a latched state.							
			F1A 0 = Input FIFO Rd/Wr pointers are not away by 1 1 = Input FIFO Rd/Wr pointers are away by 1. This is a latched state.							
			F2A 0 = Input FIFO Rd/Wr pointers are not away by 2 1 = Input FIFO Rd/Wr pointers are away by 2. This is a latched state.							
			TRDY 0 = SPI interface access is unavailable out of reset through RESETB. 1 = SPI interface access is available after a reset through RESETB. It indicates that trim loading complete after RESETB deassertion, latched status and internal configuration complete after setting GLB.CfgIFC.Xfer, latched status							
			PLLlck DAC PLL loss-of-lock, latched status. Writing 0 to clear this bit for status" 0 = locked, 1 = loss-of-lock.							
			Note	Writing 0 clears these bits and writing 1 has no effect, except for JSDII and JSDIM which are second-level statuses and cannot be cleared						
0x0165	1	iFIFOLevel	Input FIFO Level for DSP							
		Bit	7	6	5	4	3	2	1	0
		Name	iFL7	iFL6	iFL5	iFL4	iFL3	iFL2	iFL1	iFL0
		Default	0xXX							
		Definition	iFL[7:0] Input FIFO Level thermometer code, number of 1's indicating the FIFO depth							



MAX5871

16-Bit, 5.9Gps Interpolating and Modulating RF DAC with JESD204B Interface

**DSP and DAC Configuration Registers Definition and Description (continued)**

ADDRESS	BYTE	REGISTER NAME	DESCRIPTION							
0x0166	3	DieSN	MAX5871 RF DAC Serial Number							
	Bit		7	6	5	4	3	2	1	0
	Name		SN7	SN6	SN5	SN4	SN3	SN2	SN1	SN0
	Bit		15	14	13	12	11	10	9	8
	Name		SN15	SN14	SN13	SN12	SN11	SN10	SN9	SN8
	Bit		23	22	21	20	19	18	17	16
	Name		SN23	SN22	SN21	SN20	SN19	SN18	SN17	SN16
	Default			0XXXXXXXX						
Definition			SN[23:0] Serial Number of the MAX5871 RF DAC die							

**DSP and DAC Configuration Registers Definition and Description (continued)**

ADDRESS	BYTE	REGISTER NAME	DESCRIPTION							
0x0180	3	CfgPLL	Configure DAC PLL							
		Bit	7	6	5	4	3	2	1	0
		Name	PLL7	PLL6	PLL5	PLL4	PLL3	PLL2	PLL1	PLL0
		Bit	15	14	13	12	11	10	9	8
		Name	PLL15	PLL14	PLL13	PLL12	PLL11	PLL10	PLL9	PLL8
		Bit	23	22	21	20	19	18	17	16
		Name	PLL23	PLL22	PLL21	PLL20	PLL19	PLL18	PLL17	PLL16
		Default	0x004000							
		Definition	PLL[23:21] Reserved - do not write							
			PLL[20:19] (DVAL[3:2]) See decode below							
			PLL16 0 = Selects the lowband VCO 1 = Selects the highband VCO							
			PLL17, PLL15 Reserved – do not write							
			PLL14 0 = DAC PLL is not bypassed 1 = DAC PLL is bypassed							
			PLL[13:12] (DVAL[1:0]) 0100 = Feedback divider set to div-by-16 0101 = Feedback divider set to div-by-20 0110 = Feedback divider set to div-by-24 1000 = Feedback divider set to div-by-32 1001 = Feedback divider set to div-by-36 1010 = Feedback divider set to div-by-40 1100 = Feedback divider set to div-by-48							
			PLL11 (PVAL) 0 = Output divider set to div-by-2 1 = Output divider set to div-by-1							
			PLL18, PLL10 (RVAL) 00 = Reference divider control set to div-by-8 01 = Reference divider control set to div-by-4 10 = Reference divider control set to div-by-2 11 = Reference divider control set to div-by-1							
			PLL[9:2] Reserved – Do not writ							
			PLL1 Reserved – Do not write							
			PLL0 Force restart PLL digital tuning by toggling from 1 to 0 and back to 1							

**DSP and DAC Configuration Registers Definition and Description (continued)**

ADDRESS	BYTE	REGISTER NAME	DESCRIPTION							
0x0183	2	StatPLL	DAC PLL Status							
		Bit	7	6	5	4	3	2	1	0
		Name	PLLST7	PLLST6	PLLST5	PLLST4	PLLST3	PLLST2	PLLST1	PLLST0
		Bit	15	14	13	12	11	10	9	8
		Name	PLLST15	PLLST14	PLLST13	PLLST12	PLLST11	PLLST10	PLLST9	PLLST8
		Default	0xXXXX							
		Definition	PLLST[15:4] Reserved							
			PLLST3 0 = PLL not locked 1 = PLL locked							
			PLLST[2:0] Reserved							

**Link Layer Configuration Registers Definition and Description**

ADDRESS	BYTE	REGISTER NAME	DESCRIPTION							
0x0400	1	CfgSRst	Configure Soft Reset							
		Bit	7	6	5	4	3	2	1	0
		Name	X	X	X	X	X	X	srl	ila
		Default	0	0	0	0	0	0	0	0
		Definition	srl Soft reset to clear all the latched statuses							
			ila Soft reset for ILA engine							
0x0401	1	CfgLnRst	Configure Lane Reset							
		Bit	7	6	5	4	3	2	1	0
		Name	X	X	X	X	ln4	ln3	ln2	ln1
		Default	0	0	0	0	0	0	0	0
		Definition	ln[4:1] Soft reset for Lane N							

**Link Layer Configuration Registers Definition and Description (continued)**

ADDRESS	BYTE	REGISTER NAME	DESCRIPTION							
0x0402	1	CfgLinkSet	Configure Link Settings							
		Bit	7	6	5	4	3	2	1	0
		Name	idisp	scrm*	X	X	ddiv1*	ddiv0*	sclass1*	sclass0*
		Default	0	0	0	0	0	1	0	0
		Definition	idisp 0 = Do not ignore running disparity errors for data processing 1 = Ignore running disparity errors for data processing							
			scrm*							
			ddiv[1:0] 00 = Device clock to sample clock frequency ratio is 1 01 = Device clock to sample clock frequency ratio is 2 10 = Device clock to sample clock frequency ratio is 4 11 = Device clock to sample clock frequency ratio is 8							
			sclass[1:0] JESD204B Subclass (0, 1 or 2), only 00 and 01 are valid values							
0x0403	1	CfgSYSREF	Configure SYSREF Signal							
		Bit	7	6	5	4	3	2	1	0
		Name	X	valid_det	senext	rsync	smode1	smode0	ignore_en	thrsh_en
		Default	0	0	0	0	0	0	0	0
		Definition	valid_det 0 = SYSREF validity is not checked 1 = SYSREF validity is checked to be a number of symbol clocks as configured in CfgSVLD. valid[7:0]							
			senext 0 = SYSREF_EN pin is ignored 1 = SYSREF enable is controlled by SYSREF_EN pin for better timing than through SPI writes							
			rsync0 = A re-sync request is not output on SYNCN on a new SYSREF multiframe boundary 1 = A re-sync request is output on SYNCN on a new SYSREF multiframe boundary							
			smode[1:0] 00 = SYSREF is ignored 01 = The first SYSREF pulse is enabled when smode0 is toggled from 0 to 1 10 = All SYSREF pulses are enabled 11 = ReservedThese bits are only used for synchronous SYSREF mode							
			ignore_en 0 = No SYSREF pulses are dropped before smode[1:0] takes effect 1 = SYSREF pulses are dropped as configured in CfgSIGN.ign[7:0] before smode[1:0] takes effect							
			thrsh_en 0 = LMFC is reset irrespective of the new SYSREF offset 1 = LMFC is reset only if the new SYSREF offset exceeds the threshold from CfgSTHRSH. thrsh[3:0]							

**Link Layer Configuration Registers Definition and Description (continued)**

ADDRESS	BYTE	REGISTER NAME	DESCRIPTION							
0x0404	1	Cfg-STHRSH	Configure SYSREF Threshold							
		Bit	7	6	5	4	3	2	1	0
		Name	dfath3	dfath2	dfath1	dfath0	thrsh3	thrsh2	thrsh1	thrsh0
		Default	0	0	0	0	0	0	0	0
		Definition	dfath[3:0] 0 = No threshold for Dynamic FIFO adjustment 1-15 = Dynamic FIFO adjustment is suppressed when the new frame/lane boundary is offset by more than the decimal value of this field in sample clock cycles							
			thrsh[3:0] SYSREF offset threshold in sample clock cycles when enabled by CfgSYSREF.thrsh_en							
0x0405	1	CfgSIGN	Configure SYSREF Ignore Count							
		Bit	7	6	5	4	3	2	1	0
		Name	ign7	ign6	ign5	ign4	ign3	ign2	ign1	ign0
		Default	0	0	0	0	0	0	0	0
		Definition	ign[7:0] SYSREF number of pulses ignored count when enabled by CfgSYSREF.ignore_en							
0x0406	1	CfgSVLD	Configure SYSREF Valid Count							
		Bit	7	6	5	4	3	2	1	0
		Name	valid7	valid6	valid5	valid4	valid3	valid2	valid1	valid0
		Default	0	0	0	0	0	0	0	0
		Definition	valid[7:0] SYSREF validity check count of device clock cycles when enabled by CfgSYSREF.valid_det							

**Link Layer Configuration Registers Definition and Description (continued)**

ADDRESS	BYTE	REGISTER NAME	DESCRIPTION							
0x0407	1	CfgSYNCR	Configure SYNCR pin options							
		Bit	7	6	5	4	3	2	1	0
		Name	X	ret	Reserved2	cset	Reserved1	Reserved0	init	pol
		Default	0	0	0	0	0	0	0	0
		Definition	ret 0 = SYNCR is output synchronous to the internal sample clock 1 = SYNCR is retimed to device clock, useful for Subclass0 at lower frequencies This bit should be cleared when the device clock is not present (CfgLinkSrc.rclk = 1)							
			Reserved2Reserved–Do not write							
			cset0 = Disable manual control of assert/deassert frame cycle of SYNCR error reporting 1 = Enable manual control of assert/deassert frame cycle of SYNCR error reporting through Cfg-SAC and CfgSDC							
			Reserved1-0 Reserved–Do not write							
			init 0 = Out-of-reset value for SYNCR output is 0 1 = Out-of-reset value for SYNCR output is 1							
			pol 0 = SYNCR polarity is active low according to the JESD204B standard 1 = SYNCR polarity is active-high							
0x0408	1	CfgSAC	Configure SYNCR assert frame count							
		Bit	7	6	5	4	3	2	1	0
		Name	X	X	X	acnt4	acnt3	acnt2	acnt1	acnt0
		Default	0	0	0	0	0	0	0	0
		Definition	acnt[4:0] When CfgSYNCR.cset is set, this value determines the SYNCR error reporting assertion frame count							
0x0409	1	CfgSDC	Configure SYNCR deassert frame count							
		Bit	7	6	5	4	3	2	1	0
		Name	X	X	X	dcnt4	dcnt3	dcnt2	dcnt1	dcnt0
		Default	0	0	0	0	0	0	0	0
		Definition	dcnt[4:0] When CfgSYNCR.cset is set, this value determines the SYNCR error reporting deassertion frame count							

**Link Layer Configuration Registers Definition and Description (continued)**

ADDRESS	BYTE	REGISTER NAME	DESCRIPTION							
0x040A	1	CfgLink-MLFS	Configure Link for M, L, F and S							
		Bit	7	6	5	4	3	2	1	0
		Name	S	F1	F0	X	L1	L0	X	M
		Default	0	0	0	0	1	1	0	1
		Definition	S Number of samples per frame cycle is (S1), restricted to allowed combinations of L/F/S							
			F[1:0] Number of octets per frame cycle per lane is (F1), restricted to allowed combinations of L/F/S							
			L[1:0] Number of active lanes in the Link is (L1), restricted to allowed combinations of L/F/S							
			M Number of converters in the Link is (M1), should always be set to 1							
0x040B	1	CfgLinkK	Configure Link multiframe length							
		Bit	7	6	5	4	3	2	1	0
		Name	X	X	X	K4	K3	K2	K1	K0
		Default	0	0	0	0	1	1	1	1
		Definition	K[4:0] Number of frames per multiframe is (K1)							
0x040C	1	CfgBID	Configure Bank ID							
		Bit	7	6	5	4	3	2	1	0
		Name	X	X	X	X	bid3	bid2	bid1	bid0
		Default	0	0	0	0	0	0	0	0
		Definition	bid[3:0] Bank ID used for ILA sequence checking							
0x040D	1	CfgDID	Configure Device ID							
		Bit	7	6	5	4	3	2	1	0
		Name	did7-0	did6	did5	did4	did3	did2	did1	did0
		Default	0	0	0	0	0	0	0	0
		Definition	did[7:0] Device ID used for ILA sequence checking							

**Link Layer Configuration Registers Definition and Description (continued)**

ADDRESS	BYTE	REGISTER NAME	DESCRIPTION							
0x040E	4	CfgLID	Configure Lane N ID							
		Bit	7	6	5	4	3	2	1	0
		Name	X	X	X	lid1_4	lid1_3	lid1_2	lid1_1	lid1_0
		Bit	15	14	13	12	11	10	9	8
		Name	X	X	X	lid2_4	lid2_3	lid2_2	lid2_1	lid2_0
		Bit	23	22	21	20	19	18	17	16
		Name	X	X	X	lid3_4	lid3_3	lid3_2	lid3_1	lid3_0
		Bit	31	30	29	28	27	26	25	24
		Name	X	X	X	lid4_4	lid4_3	lid4_2	lid4_1	lid4_0
		Default	0x00000000							
		Definition	lidN_[4:0] Lane ID for Lane N used for ILA sequence checking							
0x0412	1	CfgLinkSrc	Configure Link signal source							
		Bit	7	6	5	4	3	2	1	0
		Name	X	X	X	X	X	X	async_avl	rclk
		Default	0	0	0	0	0	0	0	1
		Definition	async_avl 0 = Frame synchronization supports re-initialization over the data interface, monitoring the reception of /K/ characters 1 = SYNCN signals from all receivers are available and frame synchronization state machine does not support re-initialization over the data interface (no FS_CHECK state)							
			rclk 0 = Sample Clock is derived from Device Clock (CLKP/N) with a divide down set by CfgLinkSet.ddiv[1:0] 1 = Sample Clock is sourced from the DSP through the DAC Clock divided by interpolation ratio							
0x0413	1	CfgClkInv	Configure Lane Clock Inversion							
		Bit	7	6	5	4	3	2	1	0
		Name	X	X	X	X	In4	In3	In2	In1
		Default	0	0	0	0	0	0	0	0
		Definition	InN When set, invert Rx clock from SerDes							



**Link Layer Configuration Registers Definition and Description (continued)**

ADDRESS	BYTE	REGISTER NAME	DESCRIPTION							
0x0414	1	CfgLinkCtl	Configure Link control							
		Bit	7	6	5	4	3	2	1	0
		Name	cgsmen	serrc	altn	dynfadj	lcoren	fcoren	bswap	afdeti
		Default	0	0	0	1	0	0	0	0
		Definition	cgsmen When set, enable Manual Code Group Synchronization through CfgBOff serrc When set, enable SYNCN error reporting assertion/deassertion on any frame—JESD204A altn When set, enable alternate sample data mapping for MLFS=2422 dynfadj When set, enable dynamic FIFO pointer adjustment on a frame/lane synchronization change lcoren When set, enable Lane Synchronization auto-correction fcoren When set, enable Frame Synchronization auto-correction bswap When set, enable Bit Swap MSB<->LSB in an octet on all lanes afdeti When set, enable detection of invalid (Running Disparity) /A/ and /F/ characters							
0x0415	2	CfgBOff	Configure Manual Code Group Synch Bit Offsets							
		Bit	7	6	5	4	3	2	1	0
		Name	ln2_3	ln2_2	ln2_1	ln2_0	ln1_3	ln1_2	ln1_1	ln1_0
		Bit	15	14	13	12	11	10	9	8
		Name	ln4_3	ln4_2	ln4_1	ln4_0	ln3_3	ln3_2	ln3_1	ln3_0
		Default	0x0000							
		Definition	ln[4:1]_[3:0] Lane N manual Code Group Synchronization boundary enabled by CfgLinkCtl.cgsmen							
0x0417	1	CfgRstCnt	Configure SYSREF reset counts							
		Bit	7	6	5	4	3	2	1	0
		Name	X	X	oi	fi4	fi3	fi2	fi1	fi0
		Default	0	0	0	0	0	0	0	0
		Definition	oi Initial value of octet count in the frame cycle from SYSREF sampling fi[4:0] Initial value of frame count in the multiframe cycle from SYSREF sampling This value along with CfgRstCnt.oi is useful for setting the LMFC boundary relative to SYSREF							

**Link Layer Configuration Registers Definition and Description (continued)**

ADDRESS	BYTE	REGISTER NAME	DESCRIPTION							
0x0418	1	CfgILALck	Configure ILA Lock configuration							
		Bit	7	6	5	4	3	2	1	0
		Name	X	X	X	X	lksel4	lksel3	lksel2	lksel1
		Default	0	0	0	0	1	1	1	1
		Definition	lkselN ILA Lock Select mask for Lane N based on FIFO write start, 1 indicating the lane is included This field is typically set to the same value as CfgLnEn.ln[3:0] but if the lksel bit is set to 0 when the lane is enabled, that particular lane will not be included in the ILA process.							
0x0419	1	CfgILAC	Configure ILA Control							
		Bit	7	6	5	4	3	2	1	0
		Name	X	X	X	X	lsdis	ilasd1	ilasd0	dfsycn
		Default	0	0	0	0	0	0	0	0
		Definition	lsdis 0 = Lane synchronization enabled 1 = Lane synchronization disabled  ilasd[1:0] 00 = ILA sequence detection is enabled 01 = ILA sequence detection is disabled for the first CfgILASn.snum frames 10 = ILA sequence detection is disabled 11 = Reserved  dfsync 0 = Enable ILA restart on frame resynchronization 1 = Disable ILA restart on frame resynchronization							
0x041A	1	CfgILAD	Configure ILA Delay Control							
		Bit	7	6	5	4	3	2	1	0
		Name	ilam	X	idly5	idly4	idly3	idly2	idly1	idly0
		Default	0	0	0	0	0	0	0	0
		Definition	ilam 0 = Manual ILA control is disabled 1 = Manual ILA control is enabled  idly[5:0] ILA Delay sample clock count from the LMFC boundary for FIFO read start This field is useful to set the FIFO depths based on the link delay							

**Link Layer Configuration Registers Definition and Description (continued)**

ADDRESS	BYTE	REGISTER NAME	DESCRIPTION							
0x041B	4	CfgILAM	Configure Lane N Manual ILA Delay							
		Bit	7	6	5	4	3	2	1	0
		Name	X	X	In1imd5	In1imd4	In1imd3	In1imd2	In1imd1	In1imd0
		Bit	15	14	13	12	11	10	9	8
		Name	X	X	In2imd5	In2imd4	In2imd3	In2imd2	In2imd1	In2imd0
		Bit	23	22	21	20	19	18	17	16
		Name	X	X	In3imd5	In3imd4	In3imd3	In3imd2	In3imd1	In3imd0
		Bit	31	30	29	28	27	26	25	24
		Name	X	X	In4imd5	In4imd4	In4imd3	In4imd2	In4imd1	In4imd0
		Default	0x00000000							
		Definition	In[4:1]imd[5:0] Manual ILA Delay sample clock count for FIFO read start for Lane N when enabled by CfgILAD.lam							
0x041F	2	CfgILAmfs	Configure ILA Multiframe start							
		Bit	7	6	5	4	3	2	1	0
		Name	mfsel7	mfsel6	mfsel5	mfsel4	mfsel3	mfsel2	mfsel1	mfsel0
		Bit	15	14	13	12	11	10	9	8
		Name	X	X	X	X	X	X	X	Reserved0
		Default	0x0004							
		Definition	mfsel[7:0] ILA multiframe count for FIFO write start Reserved0 Reserved—do not write							
0x0421	2	CfgILAsn	Configure ILA sequence number							
		Bit	7	6	5	4	3	2	1	0
		Name	snum7	snum6	snum5	snum4	snum3	snum2	snum1	snum0
		Bit	15	14	13	12	11	10	9	8
		Name	X	X	X	X	X	X	X	Reserved0
		Default	0x0003							
		Definition	snum[7:0] Number of multiframe used for ILA sequence checking Reserved0 Reserved—do not write							

**Link Layer Configuration Registers Definition and Description (continued)**

ADDRESS	BYTE	REGISTER NAME	DESCRIPTION							
0x0423	2	CfgLerrM*	Configure Mask for error reporting on SYNCN							
		Bit	7	6	5	4	3	2	1	0
		Name	lerrm7	lerrm6	lerrm5	lerrm4	lerrm3	lerrm2	lerrm1	lerrm0
		Bit	15	14	13	12	11	10	9	8
		Name	X	lerrm14	lerrm13	lerrm12	lerrm11	lerrm10	lerrm9	lerrm8
		Default	0x0000							
		Definition	lerrm14 When set, ILA Fail error is enabled							
			lerrm13 Reserved							
			lerrm12 When set, FIFO empty error is enabled							
			lerrm11 When set, FIFO full error is enabled							
			lerrm10 When set, Lane Configuration in ILA sequence FCS check error is enabled							
			lerrm9 When set, Lane Configuration in ILA sequence mismatch error is enabled							
			lerrm8 When set, ILA sequence control character error is enabled							
			lerrm7 When set, Dynamic FIFO adjustment failure is enabled							
			lerrm6 When set, Lane realignment event is enabled							
			lerrm5 When set, Frame realignment event is enabled							
			lerrm4 When set, 8b10b /K/ character at unexpected alignment error is enabled							
			lerrm3 When set, unexpected 8b10b control character other than /K/ error is enabled							
			lerrm2 When set, 8b10b Running Disparity error is enabled							
			lerrm1 When set, 8b10b Not-in-table error is enabled							
			lerrm0 Reserved							

**Link Layer Configuration Registers Definition and Description (continued)**

ADDRESS	BYTE	REGISTER NAME	DESCRIPTION							
0x0425	2	CfgSerrM*	Configure Mask for re-sync request on SYNCN							
		Bit	7	6	5	4	3	2	1	0
		Name	serrm7	serrm6	serrm5	0	0	serrm2	serrm1	0
		Bit	15	14	13	12	11	10	9	8
		Name	X	serrm14	serrm13	serrm12	serrm11	serrm10	serrm9	serrm8
		Default	0x0000							
		Definition	serrm14 When set, ILA Fail error is enabled							
			serrm13 Reserved							
			serrm12 When set, FIFO empty error is enabled							
			serrm11 When set, FIFO full error is enabled							
			serrm10 When set, Lane Configuration in ILA sequence FCS check error is enabled							
			serrm9 When set, Lane Configuration in ILA sequence mismatch error is enabled							
			serrm8 When set, ILA sequence control character error is enabled							
			serrm7 When set, Dynamic FIFO adjustment failure is enabled							
			serrm6 When set, Lane realignment event is enabled							
			serrm5 When set, Frame realignment event is enabled							
			serrm4 Reserved = 0 only							
			serrm3 Reserved = 0 only							
			serrm2 When set, 8b10b Running Disparity error is enabled							
			serrm1 When set, 8b10b Not-in-table error is enabled							
			serrm0 Reserved = 0 only							

**Link Layer Configuration Registers Definition and Description (continued)**

ADDRESS	BYTE	REGISTER NAME	DESCRIPTION							
0x0427	2	CfgMDS	Configure Multi-DAC Synchronization							
		Bit	7	6	5	4	3	2	1	0
		Name	X	X	X	rclk	Re-served3	Re-served2	Re-served1	Re-served0
		Bit	15	14	13	12	11	10	9	8
		Name	X	X	X	Re-served8	Re-served7	Re-served6	Re-served5	Re-served4
		Default	0x0000							
		Definition	rclk When set, RSYNC from DSP replaces SYSREF This bit should be set to 1 when SYSREF is used for multi-DAC synchronization and no Device Clock is available to sample SYSREF on Reserved8-0 Reserved—do not write							
0x0429	1	CfgINV	Configure data inversion							
		Bit	7	6	5	4	3	2	1	0
		Name	X	X	X	X	ln4	ln3	ln2	ln1
		Default	0	0	0	0	0	0	0	0
		Definition	ln[4:1] 0 = Lane N octet data inversion is disabled 1 = Lane N octet data inversion is enable							
0x042A	2	CfgLnSrc	Configure Lane Source							
		Bit	7	6	5	4	3	2	1	0
		Name	X	X	ln2_1	ln2_0	X	X	ln1_1	ln1_0
		Bit	15	14	13	12	11	10	9	8
		Name	X	X	ln4_1	ln4_0	X	X	ln3_1	ln3_0
		Default	0x3210							
		Definition	ln[4:1]_[1:0] Physical Lane number source for Logical Lane N at octet-to-sample mapping							

**Link Layer Configuration Registers Definition and Description (continued)**

ADDRESS	BYTE	REGISTER NAME	DESCRIPTION							
0x042C	1	CfgLnEn	Configure Lane Enable							
		Bit	7	6	5	4	3	2	1	0
		Name	X	X	X	X	ln4	ln3	ln2	ln1
		Default	0	0	0	0	1	1	1	1
		Definition	ln[4:1] Lane N enable							
0x042D	2	CfgFIFO	Configure FIFO depths							
		Bit	7	6	5	4	3	2	1	0
		Name	X	X	X	minfd4	minfd3	minfd2	minfd1	minfd0
		Bit	15	14	13	12	11	10	9	8
		Name	X	X	X	maxfd4	maxfd3	maxfd2	maxfd1	maxfd0
		Default	0x1A06							
		Definition	maxfd[4:0] Maximum FIFO depth for dynamic adjustment and full/empty status							
			minfd[4:0] Minimum FIFO depth for dynamic adjustment and full/empty status							
0x042F	1	CfgRepl	Configure Sample Replacement on NIT error							
		Bit	7	6	5	4	3	2	1	0
		Name	X	X	X	X	X	ac	frm	sam
		Default	0	0	0	0	0	0	0	0
		Definition	ac When set, replace sample/frame for all converters with previous good sample/frame							
			frm When set, replace frame with previous good frame							
			sam When set, replace sample with previous good sample							

**Link Layer Configuration Registers Definition and Description (continued)**

ADDRESS	BYTE	REGISTER NAME	DESCRIPTION							
0x0430	1	CfgSamTest	Configure SerDes/Sample Interface Test							
		Bit	7	6	5	4	3	2	1	0
		Name	prbst1	prbst0	tprbs	rprbs	X	X	sprbs2	sprbs1
		Default	0	0	0	0	0	0	0	0
		Definition	prbst[1:0] 00 = PRBS7 for SerDes Interface 01 = PRBS23 for SerDes Interface 10 = PRBS31 for SerDes Interface 11 = Reserved							
			tprbs Enable PRBS on transmit SerDes interface, pattern based on prbst1-0							
			rprbs Enable PRBS checking on receive SerDes interface, pattern based on prbst1-0 This bit should be toggled from 0 to 1 for restarting the PRBS check							
			sprbsN Enable PRBS15 checker for converter N samples This bit should be toggled from 0 to 1 for restarting the PRBS check							
0x0431	2	CfgST-Pc1s1	Configure Short Test Pattern for Converter 1, Sample 1							
		Bit	7	6	5	4	3	2	1	0
		Name	pat7	pat6	pat5	pat4	pat3	pat2	pat1	pat0
		Bit	15	14	13	12	11	10	9	8
		Name	pat15	pat14	pat13	pat12	pat11	pat10	pat9	pat8
		Default	0x0000							
		Definition	pat[15:0] Converter 1, Sample 1 short test pattern (alternating sample test pattern)							



**Link Layer Configuration Registers Definition and Description (continued)**

ADDRESS	BYTE	REGISTER NAME	DESCRIPTION							
0x0433	2	CfgST-Pc1s2	Configure Short Test Pattern for Converter 1, Sample 2							
		Bit	7	6	5	4	3	2	1	0
		Name	pat7	pat6	pat5	pat4	pat3	pat2	pat1	pat0
		Bit	15	14	13	12	11	10	9	8
		Name	pat15	pat14	pat13	pat12	pat11	pat10	pat9	pat8
		Default	0x0000							
		Definition	pat[15:0] Converter 1, Sample 2 short test pattern (alternating sample test pattern)							
0x0435	2	CfgST-Pc2s1	Configure Short Test Pattern for Converter 2, Sample 1							
		Bit	7	6	5	4	3	2	1	0
		Name	pat7	pat6	pat5	pat4	pat3	pat2	pat1	pat0
		Bit	15	14	13	12	11	10	9	8
		Name	pat15	pat14	pat13	pat12	pat11	pat10	pat9	pat8
		Default	0x0000							
		Definition	pat[15:0] Converter 2, Sample 1 short test pattern (alternating sample test pattern)							

**Link Layer Configuration Registers Definition and Description (continued)**

ADDRESS	BYTE	REGISTER NAME	DESCRIPTION							
0x0437	2	CfgST-Pc2s2	Configure Short Test Pattern for Converter 2, Sample 2							
		Bit	7	6	5	4	3	2	1	0
		Name	pat7	pat6	pat5	pat4	pat3	pat2	pat1	pat0
		Bit	15	14	13	12	11	10	9	8
		Name	pat15	pat14	pat13	pat12	pat11	pat10	pat9	pat8
		Default	0x0000							
		Definition	pat[15:0] Converter 2, Sample 2 short test pattern (alternating sample test pattern)							
0x0500	1	CfgCnt	Configure Counter Settings							
		Bit	7	6	5	4	3	2	1	0
		Name	X	X	X	X	X	samld	rxld	cdcor
		Default	0	0	0	0	0	0	0	0
		Definition	samld Load signal for sample clock domain Lane FIFO depth update, this bit is self-clearing							
	rxld Load signal for Rx SerDes clock domain counter update, this bit is self-clearing									
	cdcor Counter data clear-on-read enable									

**Link Layer Configuration Registers Definition and Description (continued)**

ADDRESS	BYTE	REGISTER NAME	DESCRIPTION							
0x0501	1	CfgCntSel	Configure Counter Selects							
		Bit	7	6	5	4	3	2	1	0
		Name	ctsel3	ctsel2	ctsel1	ctsel0	X	X	rxtsel1	rxtsel0
		Default	0	0	0	0	0	0	0	0
		Definition	ctsel[3:0] Lane debug counter error type select for CntDbg register 0000 = No counts 0001 = NIT errors 0010 = Disparity errors 0011 = /K/ detect 0100 = /R/ detect 0101 = /Q/ detect 0110 = /A/ detect 0111 = /F/ detect 1000 = Unexpected control character error 1001 = ILA sequence control character error 1010-1111 = No counts rxtsel[1:0] 00 = Lane 1 counts enabled for CntDbg register 01 = Lane 2 counts enabled for CntDbg register 10 = Lane 3 counts enabled for CntDbg register 11 = Lane 4 counts enabled for CntDbg register							
0x0503	4	EIntLane	Lane N Interrupt Enable							
		Bit	7	6	5	4	3	2	1	0
		Name	ln1fnsync	ln1lnrealgn	ln1frrealgn	ln1uk	ln1ctrl	ln1disp	ln1nit	ln1cgs
		Bit	15	14	13	12	11	10	9	8
		Name	ln2fnsync	ln2lnrealgn	ln2frrealgn	ln2uk	ln2ctrl	ln2disp	ln2nit	ln2cgs
		Bit	23	22	21	20	19	18	17	16
		Name	ln3fnsync	ln3lnrealgn	ln3frrealgn	ln3uk	ln3ctrl	ln3disp	ln3nit	ln3cgs
		Bit	31	30	29	28	27	26	25	24
		Name	ln4fnsync	ln4lnrealgn	ln4frrealgn	ln4uk	ln4ctrl	ln4disp	ln4nit	ln4cgs
		Default	0x00000000							
		Definition	Interrupt enable for the corresponding bit in StatLane register							

**Link Layer Configuration Registers Definition and Description (continued)**

ADDRESS	BYTE	REGISTER NAME	DESCRIPTION							
0x0507	4	EIntFIFO	Lane N FIFO Interrupt Enable							
		Bit	7	6	5	4	3	2	1	0
		Name	In1fFAIL	In1empty	In1full	X	X	X	X	X
		Bit	15	14	13	12	11	10	9	8
		Name	In2fFAIL	In2empty	In2full	X	X	X	X	X
		Bit	23	22	21	20	19	18	17	16
		Name	In3fFAIL	In3empty	In3full	X	X	X	X	X
		Bit	31	30	29	28	27	26	25	24
		Name	In4fFAIL	In4empty	In4full	X	X	X	X	X
		Default	0x00000000							
		Definition	Interrupt enable for the corresponding bit in StatFIFO register							
0x050B	4	EIntILAS	Lane N ILA Sequence Interrupt Enable							
		Bit	7	6	5	4	3	2	1	0
		Name	X	In1drcv	In1kerr	In1rprbs	In1krcv	In1fchkerr	In1lcfgerr	In1ilaerr
		Bit	15	14	13	12	11	10	9	8
		Name	X	In2drcv	In2kerr	In2rprbs	In2krcv	In2fchkerr	In2lcfgerr	In2ilaerr
		Bit	23	22	21	20	19	18	17	16
		Name	X	In3drcv	In3kerr	In3rprbs	In3krcv	In3fchkerr	In3lcfgerr	In3ilaerr
		Bit	31	30	29	28	27	26	25	24
		Name	X	In4drcv	In4kerr	In4rprbs	In4krcv	In4fchkerr	In4lcfgerr	In4ilaerr
		Default	0x00000000							
		Definition	Interrupt enable for the corresponding bit in StatILAS register							
0x050F	1	EIntILA	Initial Lane Alignment Interrupt Enable							
		Bit	7	6	5	4	3	2	1	0
		Name	X	X	X	sysref_nvld	nsync	Reserved0	sysref_ndet	fail
		Default	0	0	0	0	0	0	1	0
		Definition	Interrupt enable for the corresponding bit in StatILA register							
0x0510	1	EIntLink	Link Interrupt Enable							
		Bit	7	6	5	4	3	2	1	0
		Name	X	X	prbs_c2err	prbs_c1err	X	X	stp_c2err	stp_c1err
		Default	0	0	0	0	0	0	0	0
		Definition	Interrupt enable for the corresponding bit in StatLink register							

**Link Layer Configuration Registers Definition and Description (continued)**

ADDRESS	BYTE	REGISTER NAME	DESCRIPTION							
0x0511	4	EMuteLane	Lane N Mute Enable							
		Bit	7	6	5	4	3	2	1	0
		Name	In1fnsync	In1Inrealgn	In1frrealgn	In1uk	In1ctrl	In1disp	In1nit	In1cgs
		Bit	15	14	13	12	11	10	9	8
		Name	In2fnsync	In2Inrealgn	In2frrealgn	In2uk	In2ctrl	In2disp	In2nit	In2cgs
		Bit	23	22	21	20	19	18	17	16
		Name	In3fnsync	In3Inrealgn	In3frrealgn	In3uk	In3ctrl	In3disp	In3nit	In3cgs
		Bit	31	30	29	28	27	26	25	24
		Name	In4fnsync	In4Inrealgn	In4frrealgn	In4uk	In4ctrl	In4disp	In4nit	In4cgs
		Default	0x00000000							
		Definition	Enable DAC Mute for the corresponding bit in StatLane register							
0x0515	4	EMuteFIFO	Lane N FIFO Mute Enable							
		Bit	7	6	5	4	3	2	1	0
		Name	In1fafail	In1empty	In1full	X	X	X	X	X
		Bit	15	14	13	12	11	10	9	8
		Name	In2fafail	In2empty	In2full	X	X	X	X	X
		Bit	23	22	21	20	19	18	17	16
		Name	In3fafail	In3empty	In3full	X	X	X	X	X
		Bit	31	30	29	28	27	26	25	24
		Name	In4fafail	In4empty	In4full	X	X	X	X	X
		Default	0x00000000							
		Definition	Enable DAC Mute for the corresponding bit in StatFIFO register							
0x0519	4	EMuteILAS	Lane N ILA Sequence Mute Enable							
		Bit	7	6	5	4	3	2	1	0
		Name	X	In1drcv	In1kerr	In1rprbs	In1krcv	In1fchkerr	In1lcfgerr	In1ilaerr
		Bit	15	14	13	12	11	10	9	8
		Name	X	In2drcv	In2kerr	In2rprbs	In2krcv	In2fchkerr	In2lcfgerr	In2ilaerr
		Bit	23	22	21	20	19	18	17	16
		Name	X	In3drcv	In3kerr	In3rprbs	In3krcv	In3fchkerr	In3lcfgerr	In3ilaerr
		Bit	31	30	29	28	27	26	25	24
		Name	X	In4drcv	In4kerr	In4rprbs	In4krcv	In4fchkerr	In4lcfgerr	In4ilaerr
		Default	0x00000000							
		Definition	Enable DAC Mute for the corresponding bit in StatILAS register							

Link Layer Configuration Registers Definition and Description (continued)

ADDRESS	BYTE	REGISTER NAME	DESCRIPTION							
0x051D	1	EMuteLA	Initial Lane Alignment Mute Enable							
		Bit	7	6	5	4	3	2	1	0
		Name	X	X	X	sysref_nvld	nsync	Reserved	sysref_ndet	fail
		Default	0	0	0	0	0	0	1	0
		Definition	Enable DAC Mute for the corresponding bit in StatLA register							
0x051E	1	EMuteLink	Link Mute Enable							
		Bit	7	6	5	4	3	2	1	0
		Name	X	X	prbs_c2err	prbs_c1err	X	X	stp_c2err	stp_c1err
		Default	0	0	0	0	0	0	0	0
		Definition	Enable DAC Mute for the corresponding bit in StatLink register							
0x0580	4	StatLane	Lane N Status							
		Bit	7	6	5	4	3	2	1	0
		Name	In1fnsync	In1Inrealgn	In1frrealgn	In1uk	In1ctrl	In1disp	In1nit	In1cgs
		Bit	15	14	13	12	11	10	9	8
		Name	In2fnsync	In2Inrealgn	In2frrealgn	In2uk	In2ctrl	In2disp	In2nit	In2cgs
		Bit	23	22	21	20	19	18	17	16
		Name	In3fnsync	In3Inrealgn	In3frrealgn	In3uk	In3ctrl	In3disp	In3nit	In3cgs
		Bit	31	30	29	28	27	26	25	24
		Name	In4fnsync	In4Inrealgn	In4frrealgn	In4uk	In4ctrl	In4disp	In4nit	In4cgs
		Default	0xFFFFFFFF							
		Definition	InNfnsync Frame synchronization state machine not in Sync real-time							
			InNInrealgnLane realignment occurred latched							
			InNfrrealgn Frame realignment occurred latched							
			InNuk Lane N unexpected /K/ character latched. When set, this bit is not necessarily indicating an error since /K/ can occur across the character boundaries.							
			InNctrl Lane N unexpected control character latched							
			InNdisp Lane N Disparity error latched							
			InNnit Lane N NIT error latched							
			InNcgs Lane N Code Group Synchronization out of Sync latched							

**Link Layer Configuration Registers Definition and Description (continued)**

ADDRESS	BYTE	REGISTER NAME	DESCRIPTION							
0x0584	4	StatFIFO	Lane N FIFO Status							
		Bit	7	6	5	4	3	2	1	0
		Name	In1fafail	In1empty	In1full	In1fd4	In1fd3	In1fd2	In1fd1	In1fd0
		Bit	15	14	13	12	11	10	9	8
		Name	In2fafail	In2empty	In2full	In2fd4	In2fd3	In2fd2	In2fd1	In2fd0
		Bit	23	22	21	20	19	18	17	16
		Name	In3fafail	In3empty	In3full	In3fd4	In3fd3	In3fd2	In3fd1	In3fd0
		Bit	31	30	29	28	27	26	25	24
		Name	In4fafail	In4empty	In4full	In4fd4	In4fd3	In4fd2	In4fd1	In4fd0
		Default	0XXXXXXXXX							
		Definition	InNfafail Lane N dynamic FIFO adjustment failure latched							
			InNempty Lane N FIFO empty status latched							
			InNfull Lane N FIFO full status latched							
			InNfd[4:0] Lane N FIFO depth real-time loaded when CfgCnt.samld is set to 1							

**Link Layer Configuration Registers Definition and Description (continued)**

ADDRESS	BYTE	REGISTER NAME	DESCRIPTION							
0x0588	4	StatILAS	Lane N ILA Sequence Status							
		Bit	7	6	5	4	3	2	1	0
		Name	X	In1drcv	In1kerr	In1rprbs	In1krcv	In1fchkerr	In1lcfgerr	In1ilaerr
		Bit	15	14	13	12	11	10	9	8
		Name	X	In2drcv	In2kerr	In2rprbs	In2krcv	In2fchkerr	In2lcfgerr	In2ilaerr
		Bit	23	22	21	20	19	18	17	16
		Name	X	In3drcv	In3kerr	In3rprbs	In3krcv	In3fchkerr	In3lcfgerr	In3ilaerr
		Bit	31	30	29	28	27	26	25	24
		Name	X	In4drcv	In4kerr	In4rprbs	In4krcv	In4fchkerr	In4lcfgerr	In4ilaerr
		Default	0XXXXXXXX							
		Definition	InNdrvc Lane N continuous D21.5 not-detect latched							
			InNkerr Lane N /K/ character while in frame sync latched							
			InNrprbs Lane N SerDes interface PRBS error latched							
			InNkrcv Lane N continuous /K/ not-detect latched							
			InNfchkerr Lane N ILA sequence FCHK error latched							
			InNlcfgerr Lane N ILA sequence lane configuration error latched							
			InNilaerr Lane N ILA sequence decode error latched							
0x058C	1	StatILA	Initial Lane Alignment Status							
		Bit	7	6	5	4	3	2	1	0
		Name	X	X	X	sysref_nvld	nsync	Re-served0	sysref_ndet	fail
		Default	0xXX							
		Definition	sysref_nvld SYSREF validity detection error status latched							
			nsync ILA synchronization not achieved real-time							
			Reserved0							
			sysref_ndet SYSREF detection status set until a SYSREF pulse is detected and used for LMFC reset							
			fail ILA failure latched This status is set when a lane FIFO is empty or full when the read starts							



**Link Layer Configuration Registers Definition and Description (continued)**

ADDRESS	BYTE	REGISTER NAME	DESCRIPTION							
0x058D	1	StatLink	Link Status							
		Bit	7	6	5	4	3	2	1	0
		Name	X	X	prbs_c2err	prbs_c1err	X	X	stp_c2err	stp_c1err
		Default	0xXX							
		Definition	prbs_cNerr Converter N PRBS error latched							
			stp_cNerr Converter N short test pattern error latched							
0x058E	2	CntInvlid	Counter for Invalid Errors							
		Bit	7	6	5	4	3	2	1	0
		Name	cnt7	cnt6	cnt5	cnt4	cnt3	cnt2	cnt1	cnt0
		Bit	15	14	13	12	11	10	9	8
		Name	cnt15	cnt14	cnt13	cnt12	cnt11	cnt10	cnt9	cnt8
		Default	0xXXXXX							
		Definition	cnt1[5:0] Invalid character count for lane # controlled by CfgCntSel.rxcsel1-0 This counter should be loaded by setting CfgCnt.rxid to 1							
0x0590	2	CntDbg	Counter for Lane Debug							
		Bit	7	6	5	4	3	2	1	0
		Name	cnt7	cnt6	cnt5	cnt4	cnt3	cnt2	cnt1	cnt0
		Bit	15	14	13	12	11	10	9	8
		Name	cnt15	cnt14	cnt13	cnt12	cnt11	cnt10	cnt9	cnt8
		Default	0xXXXXX							
		Definition	cnt1[5:0] Debug count type controlled by CfgCntSel.ctsel3-0 for lane # controlled by CfgCntSel.rxcsel1-0 This counter should be loaded by setting CfgCnt.rxid to 1							

\*SYNCN behavior per the JESD204B standard is to be asserted while the Rx Link is out of Code Group Synchronization (CGS). The MAX5871 asserts SYNCN (drive low) as long as any of the active lanes are out of CGS.

LNK.CfgLerrM register can be used for error reporting on SYNCN which asserts SYNCN for 2 frame clock cycles at the end of the multiframe on an error that is enabled through this register.

LNK.CfgSerrM register can be used for resynchronization request on SYNCN which asserts SYNCN for the minimum required period of "5 frames + 9 octets" on an error that is enabled through this register.

If LNK.CfgSerrM.serrm0 is set, it would interfere with the required behavior of SYNCN per the JESD204B standard and asserts SYNCN only for the minimum required period and not as long as CGS error persists.

**SERDES Common Registers Definition and Description**

ADDRESS	BYTE	REGISTER NAME	DESCRIPTION							
0x0600	1	CfgRst	Configure Reset for all Lanes							
		Bit	7	6	5	4	3	2	1	0
		Name	X	X	X	X	X	PhyKill	RstTx	Rst
		Default	0	0	0	0	0	0	0	1
		Definition	PhyKill Reserved – do not write							
			RstTx Reserved – do not write							
			Rst 0 = SerDes PHY Logic is not in reset 1 = SerDes PHY Logic is in reset							
0x0606	1	CfgRate	Configure Rate for all lanes							
		Bit	7	6	5	4	3	2	1	0
		Name	X	X	X	X	TxRate1	TxRate0	RxRate1	RxRate0
		Default	0	0	0	0	1	1	1	1
		Definition	TxRate[1:0] Reserved – do not write							
			RxRate[1:0] 00 = Reserved 01 = Serial Rate for Rx SerDes is CMU clock rate divide-by-4 10 = Serial Rate for Rx SerDes is CMU clock rate divide-by-2 11 = Serial Rate for Rx SerDes is CMU clock rate							

**SERDES Common Registers Definition and Description (continued)**

ADDRESS	BYTE	REGISTER NAME	DESCRIPTION							
0x0607	4	CfgTrain-Ln	Configure Training for Lane							
		Bit	7	6	5	4	3	2	1	0
		Name	X	X	X	X	Ln1DnGate	Ln1IdleGate	Ln1Force1	Ln1Force0
		Bit	15	14	13	12	11	10	9	8
		Name	X	X	X	X	Ln2DnGate	Ln2IdleGate	Ln2Force1	Ln2Force0
		Bit	23	22	21	20	19	18	17	16
		Name	X	X	X	X	Ln3DnGate	Ln3IdleGate	Ln3Force1	Ln3Force0
		Bit	31	30	29	28	27	26	25	24
		Name	X	X	X	X	Ln4DnGate	Ln4IdleGate	Ln4Force1	Ln4Force0
		Default	0x0D for each lane							
		Definition	Ln[4:1]DnGate 0 = Do not gate data off to Link layer when SerDes Training done status is low for lane N 1 = Gate data off to Link layer when SerDes Training done status is low for lane N							
			Ln[4:1]IdleGate 0 = Do not gate data off to Link layer when SerDes Idle detect is high for lane N 1 = Gate data off to Link layer when SerDes Idle detect is high for lane N							
			Ln[4:1]Force[1:0] 00, 11 = Reserved 01 = Deactivate training for Lane N 10 = Activate training for Lane N							
0x060B	1	CfgMisc	Configure Miscellaneous for all Lanes							
		Bit	7	6	5	4	3	2	1	0
		Name	X	X	PhyWMde1	PhyWMde0	X	BCast	Reserved	Reserved
		Default	0	0	0	0	0	1	0	0
		Definition	PhyWMde[1:0] 00 = Buffer upper 3 bytes and transfer all 4 bytes on a write to LSB for the 32-bit interface on the PHY 01 = Buffer lower 3 bytes and transfer all 4 bytes on a write to MSB for the 32-bit interface on the PHY 10 = Enable individual byte writes to the SerDes PHY 11 = Reserved							
			BCast 0 = SPI writes to one SerDes PHY are not broadcasted to all lanes 1 = SPI writes to one SerDes PHY are broadcasted to all lanes							

**SERDES Common Registers Definition and Description (continued)**

ADDRESS	BYTE	REGISTER NAME	DESCRIPTION							
0x0640	4	EIntLn	SerDes Phy Logic Interrupt Enable							
		Bit	7	6	5	4	3	2	1	0
		Name	X	X	X	X	X	Ln1SigDet	Ln1TrainDn	Ln1Phy
		Bit	15	14	13	12	11	10	9	8
		Name	X	X	X	X	X	Ln2SigDet	Ln2TrainDn	Ln2Phy
		Bit	23	22	21	20	19	18	17	16
		Name	X	X	X	X	X	Ln3SigDet	Ln3TrainDn	Ln3Phy
		Bit	31	30	29	28	27	26	25	24
		Name	X	X	X	X	X	Ln4SigDet	Ln4TrainDn	Ln4Phy
		Default	0x00000000							
		Definition	Interrupt enable for the corresponding bit in StatusLn register							
0x0644	4	EMuteLn	SerDes Phy Logic DAC Mute Enable							
		Bit	7	6	5	4	3	2	1	0
		Name	X	X	X	X	X	Ln1SigDet	Ln1TrainDn	Ln1Phy
		Bit	15	14	13	12	11	10	9	8
		Name	X	X	X	X	X	Ln2SigDet	Ln2TrainDn	Ln2Phy
		Bit	23	22	21	20	19	18	17	16
		Name	X	X	X	X	X	Ln3SigDet	Ln3TrainDn	Ln3Phy
		Bit	31	30	29	28	27	26	25	24
		Name	X	X	X	X	X	Ln4SigDet	Ln4TrainDn	Ln4Phy
		Default	0x00000000							
		Definition	DAC Mute enable enable for the corresponding bit in StatusLn register							

**SERDES Common Registers Definition and Description (continued)**

ADDRESS	BYTE	REGISTER NAME	DESCRIPTION							
0x0648	4	StatusLn	SerDes Phy Logic Status							
		Bit	7	6	5	4	3	2	1	0
		Name	X	X	X	X	X	Ln1SigDet	Ln1TrainDn	Ln1Phy
		Bit	15	14	13	12	11	10	9	8
		Name	X	X	X	X	X	Ln2SigDet	Ln2TrainDn	Ln2Phy
		Bit	23	22	21	20	19	18	17	16
		Name	X	X	X	X	X	Ln3SigDet	Ln3TrainDn	Ln3Phy
		Bit	31	30	29	28	27	26	25	24
		Name	X	X	X	X	X	Ln4SigDet	Ln4TrainDn	Ln4Phy
		Default	0XXXXXXXX							
		Definition	Ln[4:1]SigDet 0 = SerDes Idle not Detected on Lane N 1 = SerDes Idle Detected on Lane N							
			Ln[4:1]TrainDn 0 = SerDes Training Not Done on Lane N 1 = SerDes Training Done on Lane N							
			Ln[4:1]Phy 0 = PHY interrupt for Lane N is not set 1 = PHY interrupt for Lane N is set							

ADDRESS	BYTE	REGISTER NAME	DESCRIPTION							
0x0700	8	CfgCMU	Serdes CMU Configuration Register – to configure the different JESD204B rate							
	Bit		7	6	5	4	3	2	1	0
	Name		Reserved							
	Bit		15	14	13	12	11	10	9	8
	Name		Reserved							
	Bit		23	22	21	20	19	18	17	16
	Name		Reserved							
	Bit		31	30	29	28	27	26	25	24
	Name		Reserved							
	Bit		39	38	37	36	35	34	33	32
	Name		Reserved		FBDIV<1:0>		VCOSEL<1:0>		Reserved	
	Bit		47	46	45	44	43	42	41	40
	Name		Reserved							
	Bit		55	54	53	52	51	50	49	48
	Name		Cref_divsel1p0<1:0>		Reserved					
	Bit		63	62	61	60	59	58	57	56
	Name		Reserved				cd_tune1p0<2:0>			
	Default		64'h0000000000000000							
	Definition		cd_tune1p0<2:0> 3'b000 – 10G Mode 3'b100 – 7G Mode 3'b111 – 6G Mode							
			Cref_divsel1p0<1:0> 2'b00 – JESD204B internal reference div-1 2'b01 – JESD204B internal reference div-2 2'b10 – JESD204B internal reference div-4 2'b11 – JESD204B internal reference div-8							
			FBDIV<1:0> 2'b00 – divide by 40 default 2'b01 – divide by 80 2'b10 – Reserved 2'b 11 – divide by 20							
			VCOSEL<1:0> 2'b00 – 10G Mode 2'b10 – 7G Mode 2'b11 – 6G Mode							

**Applications Information**

**Typical Configuration**

The overall configuration of the MAX5871 includes setting up the clocking as described in the following sections and setting all other configurations before or after that. Configuration registers other than the clocking includes the DSP, JESD204B Clock Multiplier Unit (CMU), SerDes, and Rx Link registers.

**MAX5871 Flow Chart**

The following is the overall flowchart from power-up to DAC output enable. Some of the intermediate steps are mode specific and described below.

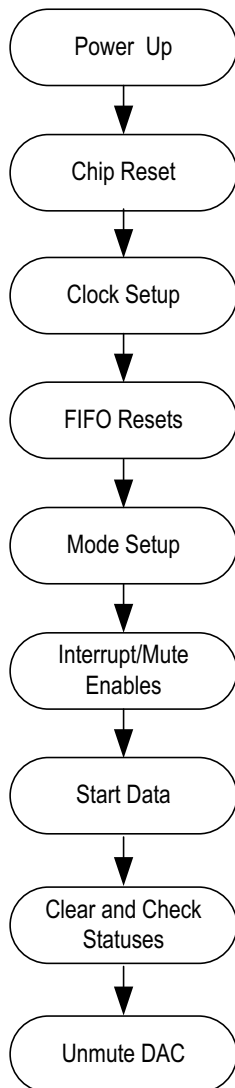

**Power Up**

Ramp up power for all supplies and this does not require any particular order.

**Chip Reset**

Assert chip reset RESETB for 1µs. After reset release, either monitor the INTB pin to go low or poll the DSP.STATUS.TRDY bit to go high. This indicates that device trimming is complete and is ready for configuration.

**Clock Setup**

Clock setup includes configuring the clock sources for the DAC, DSP, and JESD204B functions. The clocking depends on the required setup including the following. This also includes the JESD204B subclass mode since it determines how the FIFOs come up centered in a known state.

- 1) DAC PLL usage
- 2) Device Clock availability for JESD204B function
- 3) DSP interpolation rate

For JESD204B Subclass-0 with device clock used for generating the sample clock, the following clock setup is required

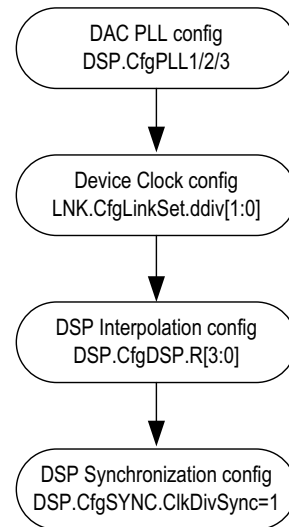

For JESD204B Subclass-0 with DSP used for generating the sample clock, the following clock setup is required.

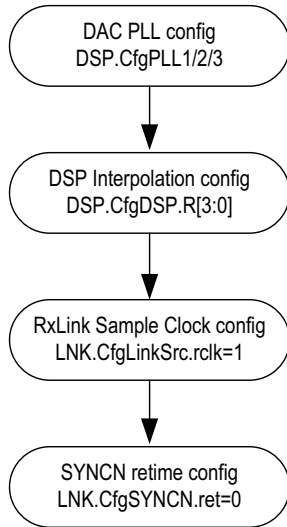

For JESD204B Subclass-1 with device clock used for generating the sample clock and a synchronous SYSREF to device clock, the following clock setup is required.

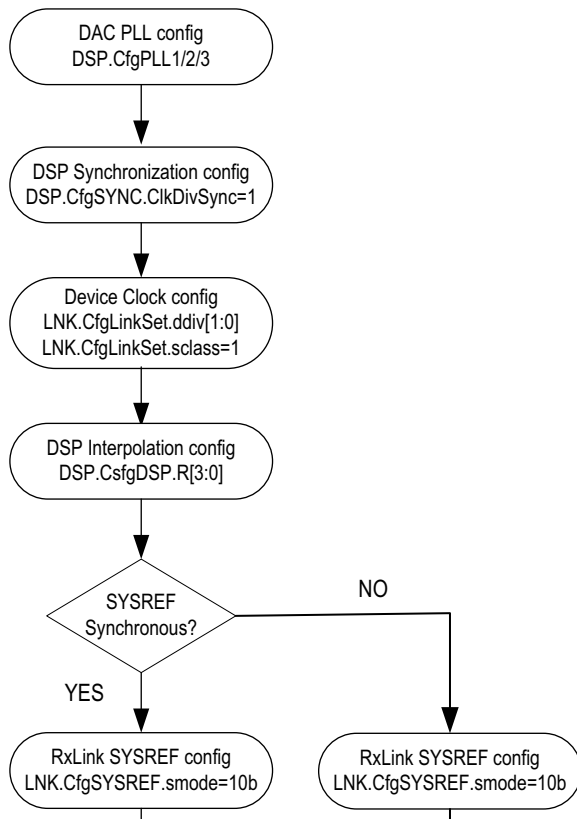

For JESD204B Subclass-1 with DSP used for generating the sample clock and an asynchronous SYSREF, the following clock setup is required.

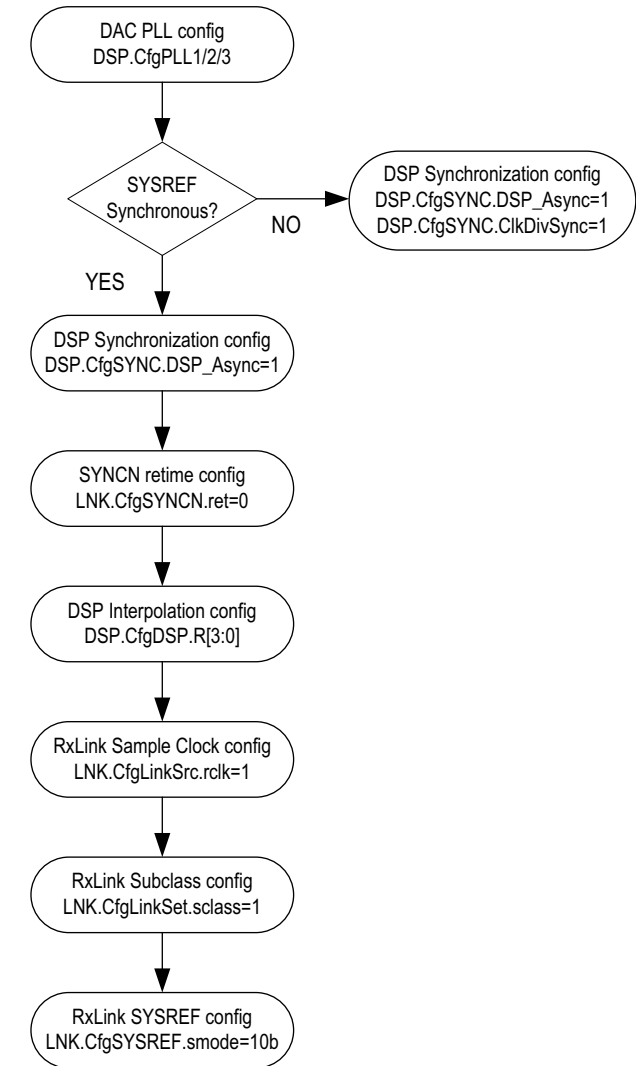

**FIFO Resets**

After the clock modes are setup and after a sufficient wait time for the DAC PLL to lock, the DSP clock divider needs to be reset and then the Rx Link and DSP FIFOs need to be centered through configuration in Subclass-0 mode or SYSREF in Subclass-1 mode.



Subclass-0 with Device Clock

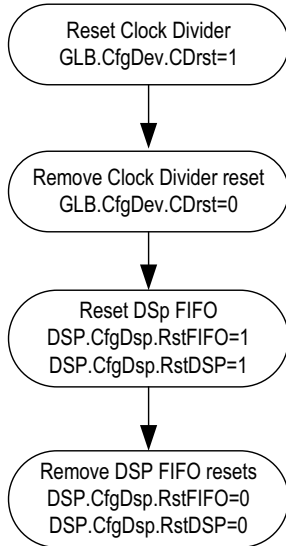

Subclass-0 without Device Clock

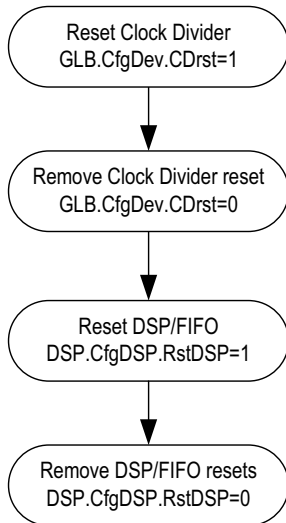

Subclass-1 with Device Clock (and Synchronous SYSREF)

Or

Subclass-1 without Device Clock (and Asynchronous SYSREF)

**Pulse SYSREF**

**Mode Setup**

Setup device modes other than DAC PLL, clocking, synchronization, and resets.

**Interrupt/Mute Enables**

Enable internal DAC mute and interrupt enables in the JESD204B RxLink and DSP registers.

**Start Data**

Start JESD204B link data carrying the signal.

**Clear and Check Statuses**

Clear all the latched statuses enabled for internal DAC mute and interrupt.

**Unmute DAC**

Reset DAC mute register bit (DSP.CfgChipOM.Mute) to enable the DAC output.

## JESD204B Rx Link and DSP Clcking

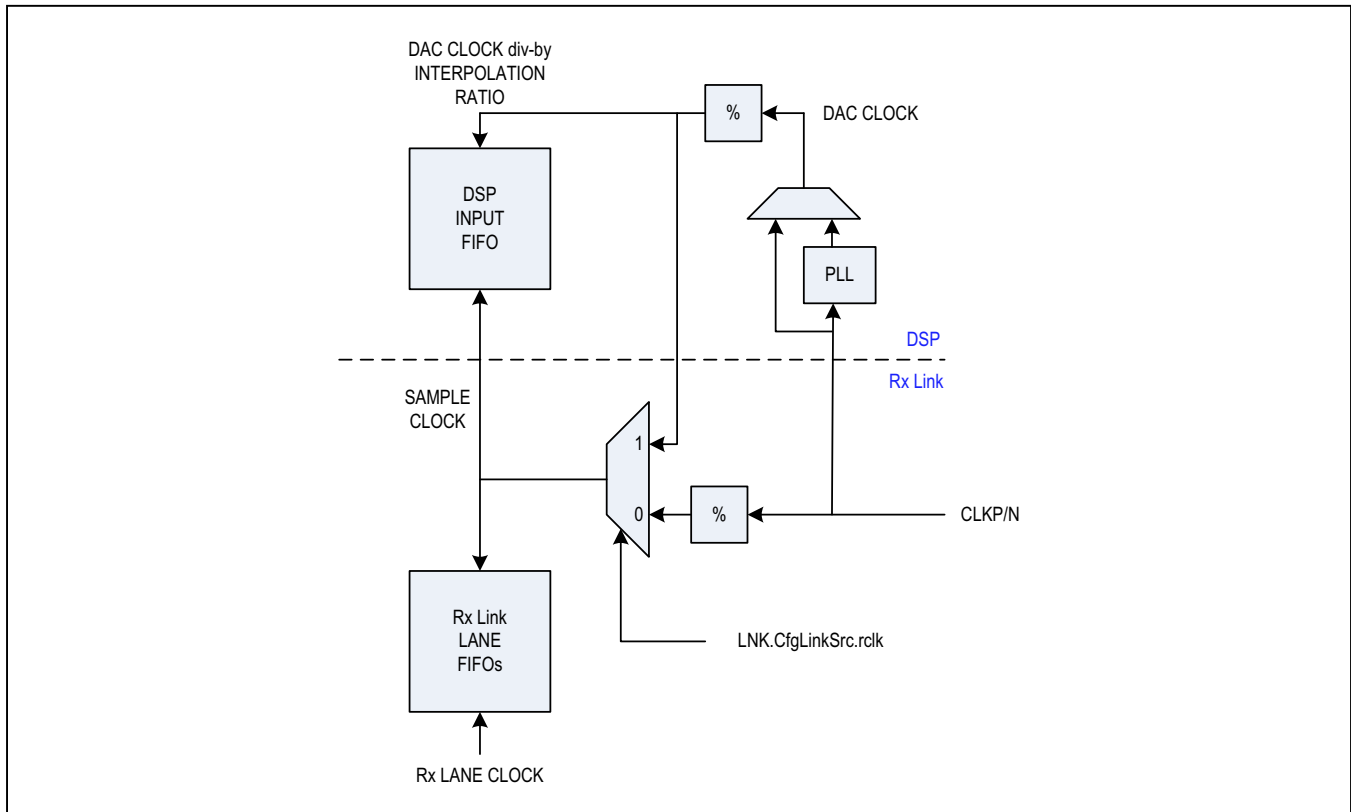

Figure 40. Rx Link and DSP Clcking

**Subclass-0 with Device Clock**

When there is a device clock present on the CLKP/N pins, the Rx Link sample clock is generated from it and the DSP input FIFO removes the phase difference between this Rx Link sample clock and DSP sample clock. This mode is set by `LNK.CfgLinkSrc.rclk=0`. The DSP sample clock is stable when the DAC clock is stable through or bypassing the DAC PLL and Interpolation Mode is set via `DSP.CfgDSP.R[4:0]`. The Rx Link sample clock is stable when the device clock divide mode is selected via `LNK.CfgLinkSet.ddiv[1:0]`. Once these clocks for the DSP Input FIFO are stable, it needs to be reset to be centered. The Rx Link Lane FIFOs are controlled by the Subclass-0

behavior with minimum latency through the FIFO. The FIFO latency can be increased via `LNK.CfgILAD[5:0]` in sample clock period increments. The following is the required configuration order for this mode to be stable.

- 1) Configure DAC PLL registers if DAC PLL is used (`DSP.CfgPLL`)
- 2) Configure RxLink device clock divide factor (`LNK.CfgLinkSet.ddiv[1:0]`)
- 3) Set interpolation mode and reset input FIFO (`DSP.CfgDSP.R[3:0]`, `DSP.CfgDSP.RstFIFO`)
- 4) Remove DSP Input FIFO reset (`DSP.CfgDSP.RstFIFO`)

**Subclass-0 without Device Clock**

When there is no device clock present on CLKP/N pins, the RxLink sample clock is sourced from the DSP sample clock. This mode is set by `LNK.CfgLinkSrc.rclk=1`. The DSP sample clock is stable when DAC clock is stable through or bypassing the DAC PLL and interpolation Mode is set via `DSP.CfgDSP.R[4:0]`. Once this clock for the DSP Input FIFO (same write and read clock) is stable, it needs to be centered by disabling and enabling the FIFO with an adjusted read pointer. The RxLink lane FIFOs are controlled by the subclass0 behavior with minimum latency through the FIFO. The FIFO latency can be increased via `LNK.CfgILAD[5:0]` in sample clock period increments. The following is the required configuration order for this mode to be stable.

- 1) Configure DAC PLL registers if DAC PLL is used (`DSP.CfgPLL`)
- 2) Set interpolation mode (`DSP.CfgDSP.R[3:0]`)
- 3) Set the RxLink clock mode (`LNK.CfgLinkSrc.rclk=1`)
- 4) Disable the input FIFO and set FIFO read pointer (`DSP.CfgFIFO.Off=1`, `DSP.CfgFIFO.RdPtrAdj[3:0]=6`)
- 5) Enable the input FIFO (`DSP.CfgFIFO.Off=0`)
- 6) Disable SYNCN retiming to device clock (`LNK.Cfg-SYNCN.ret=0`)

**Subclass-1 with Device Clock**

This is the true JESD204B Subclass1 mode with the SYSREF input synchronous to CLKP/N (device clock) input. The RxLink sample clock is generated from a divide down of device clock. The DSP input FIFO removes the phase difference between the RxLink sample clock and the DSP sample clock. This mode is set by `LNK.CfgLinkSrc.rclk=0`. The DSP sample clock is stable when DAC clock is stable through or bypassing the DAC PLL and interpolation Mode is set via `DSP.CfgDSP.R[4:0]`. The RxLink sample clock is stable when the device clock divide mode is selected via `LNK.CfgLinkSet.ddiv[1:0]`. The Subclass1 deterministic delay process including the `LNK.CfgILAD[5:0]` sets the RxLink FIFO depths followed by a reset of the DSP input FIFO through the DSP clock divider. The following is the required configuration order for this mode to be stable.

- 1) Configure DAC PLL registers if DAC PLL is used (`DSP.CfgPLL`)

- 2) Enable DSP clock-divider reset from RxLink (`DSP.CfgSYNC.ClkDiv_Sync=1`)
- 3) Set interpolation mode (`DSP.CfgDSP.R[3:0]`)
- 4) Set RxLink device clock divide factor and subclass1 mode (`LNK.CfgLinkSset.ddiv[1:0]`, `LNK.CfgLinkSet.sclass[1:0]=01`)
- 5) Enable SYSREF pulses to set RxLink LMFC boundary (`LNK.CfgSYSREF.smode[1:0]=10`)

**Subclass-1 without Device Clock**

This is a pseudo JESD204B Subclass1 mode with the SYSREF input asynchronous to the CLKP/N input. The RxLink sample clock is sourced from the DSP sample clock. This mode is set by `LNK.CfgLinkSrc.rclk=1`. The DSP sample clock is stable when DAC clock is stable through or bypassing the DAC PLL and interpolation mode is set via `DSP.CfgDSP.R[4:0]`. The SYSREF signal centers the DSP Input FIFO through the DSP clock divider followed by the Subclass1 deterministic delay process including the `LNK.CfgILAD[5:0]` setting RxLink FIFO depths. DSP input FIFO should not be reset through the `DSP.CfgDSP.RstFIFO` or `DSP.CfgDSP.RstDSP` in this mode. The SYSREF signal can be a continuous clock or a one-shot pulse. The following is the required configuration order for this mode to be stable.

- 1) Configure DAC PLL registers if DAC PLL is used (`DSP.CfgPLL`)

If SYSREF is a continuous clock-like signal:

- 2) Enable first SYSREF pulse to reset DSP clock divider (`DSP.CfgSYNC.DSP_ASync=1`)

If SYSREF is a one-shot pulse:

- 2) Enable continuous SYSREF pulses to reset DSP clock divider (`DSP.CfgSYNC.DSP_ASync=1`, `DSP.CfgSYNC.ClkDiv_Sync=1`)
- 3) Disable SYNCN retiming to device clock (`LNK.Cfg-SYNCN.ret=0`)
- 4) Set interpolation mode (`DSP.CfgDSP.R[3:0]`)
- 5) Set the RxLink clock mode (`LNK.CfgLinkSrc.rclk=1`)
- 6) Set RxLink SYSREF mode (`LNK.CfgMDS.rclk=1`)
- 7) Set Subclass1 mode (`LNK.CfgLinkSet.sclass[1:0]=01`)
- 8) Enable SYSREF pulses to set RxLink LMFC boundary (`LNK.CfgSYSREF.smode[1:0]=10`)

**MAX5871 Configuration**

The MAX5871 can be configured by following the examples below. There are two groups of registers: fixed and variable. The fixed group of registers given in this example should be used independent of your application. The variable group of registers given in this example should be modified based on the MAX5871 register definition and description for your application, such as DAC sampling rate, DAC clock input, interpolation ratio, SerDes data rate, JESD204B format, and interrupt handling.

**MAX5871 Example Configuration Option-1**

Application requirement

DAC Rate = 5898.24MHz

SerDes Rate = 7372.8Mbps

CLKP/N Rate = 1474.56MHz

Equivalent I or Q Sample Rate = 737.28MSPS

JESD204B LFS = 411

Interpolation = 8x

NCO Frequency = 800MHz

0x0000,0x99; //GLB.CfgIFA.4Wire=1, SftRst=1 (self-clearing)

0x0010,0x0A; //fDAC=1010b

//DVAL is 32, RVAL is 8, PVAL is 1

0x0181,0x08; //DSP.CfgPLL2.DVAL[1:0]=00b, RVAL0=0, PVAL=1, Bypass=0

0x0182,0x11; //DSP.CfgPLL3.VCOSEL=1, DVAL[3:2]=10b, RVAL1=0

0x0180,0x03; //DSP.CfgPLL1.DigTune=1, Reserved=1

0x015A,0x80; //DSP.CfgSYNC.DSP\_ASync=1

0x0101,0xB0; //DSP.CfgDSP.R=1011b

0x0427,0x10; //LNK.CfgMDS.rclk=1

0x0412,0x01; //LNK.CfgLinkSrc.rclk=1

0x0402,0x01; //LNK.CfgLinkSet.sclass=01b

0x0403,0x18; //LNK.CfgSYSREF.rsync=1, smode=10b

0x0002,0x00; //GLB.CfgDev.CDrst=0

0x0002,0x00; //GLB.CfgDev.CDrst=0

0x0002,0x00; //GLB.CfgDev.CDrst=0

0x0002,0x00; //GLB.CfgDev.CDrst=0

0x0002,0x00; //GLB.CfgDev.CDrst=0

0x0002,0x00; //GLB.CfgDev.CDrst=0

0x0002,0x04; //GLB.CfgDev.CDrst=1

0x0002,0x00; //GLB.CfgDev.CDrst=0

0x0407,0x00; //LNK.CfgSYNCRN.ret=0

0x041F,0x04; //LNK.CfgILAmfs.mfSel=4

0x0421,0x03; //LNK.CfgILAsn.snum=3

0x040A,0x0D; //LNK.CfgMLFS.L=4, F=0, S=0, M=1

0x042C,0x0F; //LNK.CfgLnEn.ln=1111b

0x0418,0x0F; //LNK.CfgLALck.lkSel=1111b

0x041A,0x05; //LNK.CfgLAD.idly=10

0x0414,0x1C; //LNK.CfgLinkCtl.lcoren=1, fcoren=1, dyn-fadj=1

0x042D,0x06; //LNK.CfgFIFO.minfd=6

0x042E,0x1A; //LNK.CfgFIFO.maxfd=26

0x0600,0x00; //SER.CfgRst.Rst=0

0x0606,0x03; //SER.CfgRate.RxRateSel=11b

0x0607,0x01; //SER.CfgTrainLn.Ln1IdleGate=0, Ln1DnGate=0

0x0608,0x01; //SER.CfgTrainLn.Ln2IdleGate=0, Ln2DnGate=0

0x0609,0x01; //SER.CfgTrainLn.Ln3IdleGate=0, Ln3DnGate=0

0x060A,0x01; //SER.CfgTrainLn.Ln4IdleGate=0, Ln4DnGate=0

0x060B,0x04; //SER.CfgMisc.BCast=1

0x0704,0x38; //SER.CfgCMU.VCOSEL=10b, FBDIV=11b

0x0706,0x40; //SER.CfgCMU.Cref\_divsel1p0=01b

0x0707,0x04; //SER.CfgCMU.cd\_tune1p0=100b

0x082F,0x08;	0x080E,0x15;
0x082E,0x1F;	0x080D,0x02;
0x082D,0x00;	0x080C,0x4E;
0x082C,0x00;	0x0813,0x42;
0x0867,0x00;	0x0812,0x00;
0x0866,0x00;	0x0811,0x20;
0x0865,0x0C;	0x0810,0x7D;
0x0864,0x00;	0x0817,0xFB;
0x084B,0xFF;	0x0816,0x0A;
0x084A,0x77;	0x0815,0x19;
0x0849,0xFD;	0x0814,0xE9;
0x0848,0x40;	0x081B,0x00;
0x0803,0x02;	0x081A,0x00;
0x0802,0x10;	0x0819,0x07;
0x0801,0x21;	0x0818,0x75;
0x0800,0x08;	0x081F,0x80;
0x0807,0x04;	0x081E,0xFF;
0x0806,0xAF;	0x081D,0x08;
0x0805,0x40;	0x081C,0x00;
0x0804,0x00;	0x0823,0x07;
0x0857,0xFC;	0x0822,0x20;
0x0856,0x01;	0x0821,0x10;
0x0855,0x00;	0x0820,0x00;
0x0854,0x35;	0x0827,0x00;
0x0863,0x00;	0x0826,0x3F;
0x0862,0x54;	0x0825,0x10;
0x0861,0x00;	0x0824,0x00;
0x0860,0x06;	0x0833,0x1F;
0x0893,0x00;	0x0832,0x7F;
0x0892,0x51;	0x0831,0x20;
0x0891,0x23;	0x0830,0x00;
0x0890,0x26;	0x088F,0x00;
0x080B,0x0C;	0x088E,0x00;
0x080A,0x87;	0x088D,0x80;
0x0809,0xD3;	0x088C,0x80;
0x0808,0xFF;	0x08AB,0x00;
0x080F,0x4C;	0x08AA,0x04;

0x08A9,0x43;	0x0869,0x2A;
0x08A8,0x01;	0x0868,0x25;
0x083F,0xAF;	0x086F,0xC0;
0x083E,0x34;	0x086E,0x00;
0x083D,0xAF;	0x086D,0x02;
0x083C,0x80;	0x086C,0xEE;
0x0843,0x00; //Status	0x0873,0x00;
0x0842,0x00;	0x0872,0x00;
0x0841,0x00;	0x0871,0x00;
0x0840,0x00;	0x0870,0x00;
0x0847,0x10;	0x087B,0x00;
0x0846,0x00;	0x087A,0x7F;
0x0845,0x80;	0x0879,0xD5;
0x0844,0x80;	0x0878,0x56;
0x0853,0x2A;	0x087F,0xC5;
0x0852,0x8B;	0x087E,0x46;
0x0851,0x40;	0x087D,0x1C;
0x0850,0x20;	0x087C,0x17;
0x085F,0x7F;	0x0102,0x1C; //DSP.CfgNCOF0=1Ch
0x085E,0x01;	0x0103,0xC7; //DSP.CfgNCOF1=C7h
0x085D,0x3F;	0x0104,0x71; //DSP.CfgNCOF2=71h
0x085C,0xFF;	0x0105,0x45; //DSP.CfgNCOF3=45h
0x084F,0x00;	0x0101,0xB1; //DSP.CfgDSP.R=1011b, NCOLoad=1
0x084E,0x40;	0x0100,0x45; //DSP.CfgChipOM.RclkM=2, DFMT=1, Mute=1
0x084D,0x00;	0x000F,0x01; //GLB.CfgIFC.Xfer=1
0x084C,0x18;	0x0000,0x3C; //DSP.CfgChipOM.RclkM=2, DFMT=1, Mute=0
0x086B,0x00;	
0x086A,0x00;	

### JESD204B Subclass-1 SYSREF Signal Functionality

There are two modes of JESD204B Subclass-1 operation: synchronous SYSREF mode and asynchronous SYSREF mode. The synchronous SYSREF mode is as described in the standard with SYSREF timed synchronously to the device clock. The asynchronous SYSREF mode does not require a device clock and so SYSREF has no timing reference. The JESD204B sample clock is sourced from the DSP in this case.

#### Synchronous SYSREF Mode

As described for the JESD204B Subclass-1 deterministic delay, the SYSREF input signal is synchronous to the device clock input (CLKP/N) and the sample clock is sourced from the device clock. The SYSREF signal can be generated from a clock generator module in which case the SYSREF will be a divided down version of the device clock. Register configurations exist as below to respond to either the first SYSREF pulse or all SYSREF pulses.

LNK.CfgSYSREF.smode[1:0] – when smode[1] is high, all SYSREF pulses are acted upon. When smode[1] is low, only the first SYSREF pulse after smode[0] is

toggled 0->1 will be acted upon. If CfgSYSREF.ignore\_en is set, then the ignore function is given a higher priority smode[1:0]=01 will enable first SYSREF only after the CfgSIGN.ign[7:0] pulses are ignored.

This is required for the case of the device clock frequency being higher than what is supported by the MAX5871 and SYSREF timing to the device clock is not truly synchronous. An uncertainty of one device clock in sampling SYSREF is allowed in this case. If all SYSREF pulses are enabled, the internal frame/multiframe clocks may not be stable and so only one SYSREF pulse needs to be enabled for link establishment.

In the case where multiple converters need to be aligned, a register write to enable a single SYSREF pulse may not be suitable as the synchronization of these register writes may be harder. This can be handled by using a hardware enable of SYSREF through the SYSREF\_EN pin as shown in the timing diagram below.

LNK.CfgSYSREF.senext – When this bit is set, the CfgSYSREF.smode[1:0] are ignored and the external pin sysref\_en is used instead. This allows for better timing control of enabling SYSREF pulses to affect LMFC.

**Asynchronous SYSREF Mode**

In this mode, a device clock is not required and SYSREF is used for JESD204B Subclass1 mode through the DSP. The DSP generates the sample clock and a synchronous signal to replace the JESD204B RxLink SYSREF input. This mode is enabled by setting the following configuration register bits.

LNK.CfgLinkSrc.rclk – when set, the sample clock is sourced from RCLK input instead of the device clock. Along with setting this bit high, an equivalent bit in the DSP, CfgSync.DSP\_ASync, needs to be set to ignore the VALID output from this block and instead use the SYNCO output (SYSREF passed through) and generate RSYNC based on it. This affects the multi-DAC synchronization and the CfgMDS.rclk also needs to be set for the link to replace SYSREF with RSYNC at the same time RCLK is used for sample clock.

LNK.CfgMDS.rclk – when set, RSYNC input from DSP/ DAC replaces the SYSREF input for multi-DAC synchronization when there is no device clock supplied. This bit should be used in conjunction with CfgLinkSrc.rclk.

DSP.CfgSync.DSP\_ASync – when set, asynchronous SYSREF reset to the DSP is enabled.

The SYSREF\_EN input signal is ignored in this mode, the SYSREF\_EN pin (also called SYSREFEN) should be connected to the VDD2 supply. The same issue described in the synchronous SYSREF mode exists here if SYSREF is a continuous clock-like signal due to its asynchronous timing. Instead, if SYSREF is generated as a one-shot pulse, then the register bit DSP.CfgSync.ClkDiv\_Sync should be set high for the DSP to respond to all the SYSREF pulses as shown below.

DSP.CfgSync.ClkDiv\_Sync – when set and DSP\_Async=1, enable continuous asynchronous SYSREF reset to the clock-divider block. When cleared and DSP\_Async=1, enable first asynchronous SYSREF reset to the clock-divider block.

If the SYSREF signal is generated as a continuous clock, then the register bit DSP.CfgSync.ClkDiv\_Sync should be set low for the DSP to respond to one of the SYSREF pulses as shown below.

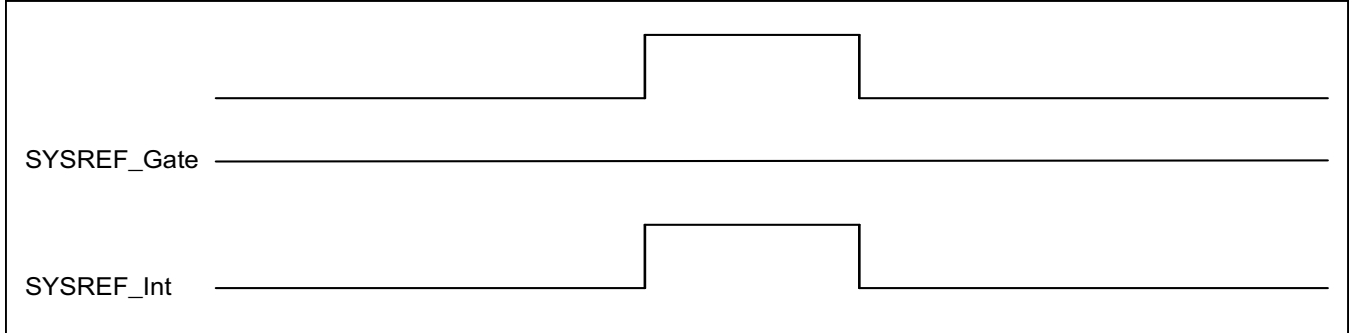

Figure 41. Asynchronous SYSREF Mode with One-Shot Pulse

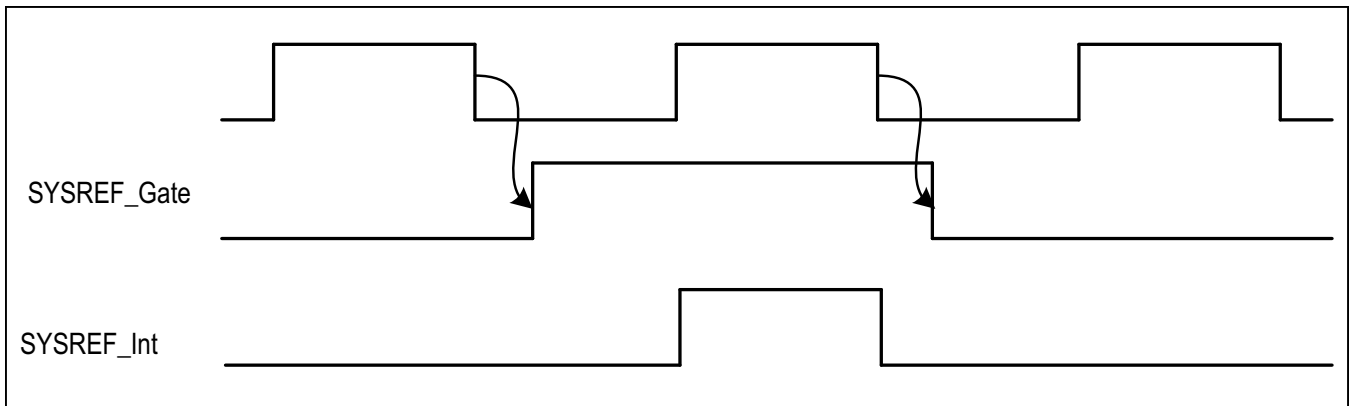

Figure 42. Asynchronous SYSREF Mode with Continuous Pulses



## Applications Guidelines

### Power Sequence

The MAX5871 typically does not require a specific power sequence on which power supplies should be up first, and which is next. It is recommended that all the supplies are powered up around the same time.

### Power Supply AVCLK

Power supply AVCLK is the most sensitive clock. To achieve specified DAC performance, this supply should NOT be shared with other 1.0V supplies. It should absolutely not be shared with digital V<sub>DD</sub> 1.0V supply.

### Power-On RESETB and SPI Configuration

During the initial power-on, the RESETB pin should be held low during the power-on of the device. In addition, RESETB has an internal pulldown resistor about 32kΩ. This pin should be pull-high after all the power supplies are completely on.

Another way to handle the RESETB is to pull the RESETB to low after the power supplies are fully up, and then pull the RESETB to high.

There is a delay time required after the RESETB is high to SPI configuration can be started. The delay time is to allow the device finishing the initialization process. The delay is related to the CLKP/N frequency. It is about 250μs with CLKP/N device clock frequency of 1.47GHz.

### Delay Time TD\_DivRst Estimation

Adding proper delay time before resetting the internal divider is important to make sure that the internal divider starts with a stable clock after the DAC PLL (or external CLKP/N) is fully locked and settled. The minimum time is estimated as  $(220/PFD\_FREQ)$ , where PFD\_FREQ is the input frequency of the DAC PLL phase frequency detector in PLL on mode. For example, when CLKP/N frequency is at 982.68MHz, the reference divider RVAL is set to be 1/4,  $PFD\_FREQ = 982.68/4 = 245.67\text{MHz}$ . The TD\_DivRst is estimated as 4.3ms.

### Pin DACREF Consideration

The 1.27kΩ resistor from FSADJ (B2) should connect directly to DACREF (B1). This should be placed on the same side as the MAX5871 package and as close as possible to the package. Also, 1μF capacitors connected to REFIO(A1) and CSBP (A2) should connect to DACREF, not GND. These should also be placed on the same layer as the DAC package, avoiding VIAs in all these traces if possible. DACREF is not connected to GND externally.

### DAC PLL Consideration

Connections to PLL\_COMP(A12) and VCOBYP(B11)—loop filter for the PLL (see Figure 29). Place external components on the PCB layer opposite the CLK and OUTPUT circuits to prevent them from coupling. The recommended filter between PLL\_COMP(A12) and VCOBYP(B11) is 650Ω in series with 4.7nF. The capacitor, C1, reduces noise from GND(A11) to VCOBYP(B11). Place C1 directly under the balls/vias of the package to make this loop as small as possible. The exact values of C1 and C2 vary because they depend on PCB layout, and may or may not be required for optimal performance.

### Pin SDO Consideration

In 4-wire SPI interface mode, SDO is used as a data output. When connecting multiple SDOs together using CSB to access the MAX5871, it is recommended to have a pullup 10kΩ resistor on the input of FPGA or ASIC to prevent floating (need a different term) bus. When SDO is not selected, it outputs tri-state (need a different term due to copyright issues),

### Clock Requirement

The MAX5871 can be operated with DAC PLL ON or DAC PLL OFF.

When DAC PLL is OFF, a clock requirement document is available upon request.

When DAC PLL is ON, the DAC PLL bandwidth is set to around 100kHz. It means that any phase noise/jitter of the reference clock at frequency offsets higher than 100kHz will be filtered out by the PLL loop and its impact on the DAC performance will be minimal.

However, for offsets smaller than 100kHz, the reference clock phase noise will dominate. At those offsets, the reference clock phase noise will be translated to the DAC output phase noise according to the formula:

$$PN_{\text{out}} [\text{dBc/Hz}] = PN_{\text{ref}} [\text{dBc/Hz}] + 20 \times \log(f_{\text{C}}/f_{\text{REF}})$$

Where:

PN<sub>out</sub> – DAC output phase noise

PN<sub>ref</sub> – PLL reference clock phase noise

f<sub>C</sub> – DAC output frequency

f<sub>REF</sub> – PLL reference clock frequency

In addition to the reference clock phase noise and jitter, the allowable spur level in the reference clock spectrum should be calculated using graphs and equations that are available upon request.

**NCO Frequency**

NCO frequency can have two types of errors from the NCO and DAC clocks used. One type of error is from NCO itself due to finite word length. The frequency error can be calculated by  $f_{\text{error}} = f_{\text{desired}} - f_{\text{DAC}} / ((218) \times (233) \times 2)$ . This is about 1.11 $\mu$ Hz error at 5GHz DAC clock rate that is negligible.

Register DFW has 19 bits and NFW has 18 bits. To minimize NCO frequency error, DFW can be always programmed to 0x3FFFF and set NFW based on the fractional portion of the calculated FCW. This limits the NCO frequency error to 1.11 $\mu$ Hz. The MATLAB code however can give an error of 0Hz if possible.

Another error is related to DAC input sampling clock. The NCO synthesizes frequency, which is an exact fraction of the DAC core clock frequency. That fraction value can be calculated using equation provided in the data sheet. Any percentage error in the DAC input clock, either with PLL enabled or disabled will result in the same percentage error at the NCO output. For example, if the DAC input clock has a tolerance of 10ppm, the NCO output frequency will also have a tolerance of 10ppm.

The DAC PLL does not introduce any frequency error once it is locked. The PLL output frequency is exactly equal to the input reference frequency multiplied by the selected PLL multiplication factor.

**Latency**

There are two types of latencies in MAX5871: JESD204B latency and DAC latency.

The JESD204B Rx link layer includes a lane processing latency and this combined with the transmit link latency and the channel latency, the Subclass-1 deterministic delay should be set through the MAX5871 configuration. This process is to be characterized from silicon evaluation. The lane processing delay portion of the JESD204B RxLink is 200 SerDes bit clocks. In addition to this, there would be a FIFO delay in sample clock periods as configured for Subclass1 deterministic delay.

The DAC latency is given in the Electrical Characteristics table in the unit of DAC clock periods.

**Turn off JESD204B Transmitter**

The MAX5871 JESD204B consists of both receiver and transmitter blocks. The transmitter is only for manufacturer test purposes. To make sure the transmitters are turned off to save power consumption, the following configuration can be used:

Write 0x0849 = 0xC1 to turn off SerDes TX

**PRBS Sequence**

PRBS7 and PRBS 23 are supposed to be inverted according to Table 3 in [http://www.xilinx.com/support/documentation/application\\_notes/xapp884\\_PRBS\\_GeneratorChecker.pdf](http://www.xilinx.com/support/documentation/application_notes/xapp884_PRBS_GeneratorChecker.pdf)

The MAX5871 Rx PHY has an option to invert the data by setting PHY.MISC\_REG2.Rx\_parallel\_data\_invert (bit 4).

**DSP FIFO Reading**

When reading the DSP FIFO register, the number of ones indicates the FIFO level. The 0x1F depth indicates that the level is 5, meaning that the read pointer is behind the write pointer by 5. The FIFO level should be used only for debug. The error conditions are DSP.STATUS.FCOL and DSP.STATUS.F1A while the third status DSP.STATUS.F2A is a warning condition (close to overflow or underflow, one specifically can be determined through DSP.iFIFOLevel).

**DAC Output Impedance Model and Matching Network**

The DAC output impedance model is available in an s-parameter file that can be used to design an output matching network if needed.

For the best engineering practice, the following guidelines can help in the output PCB design:

- DAC OUTP and OUTN routes to the matching network should be as short as possible. From the matching network to any filter should be as short as possible.
- DAC OUTP and OUTN should be routed symmetrically to eliminate any mismatch.
- The environment around OUTP and OUTN should be symmetrical. This means that the environment on one signal needs to match the other signal.
- If OUTP and OUTN cannot be made to be short trace routes, then the routes need to match length with mirror symmetry and 50 $\Omega$  routed impedance.
- When crossing other signals/supplies routed on other layers, OUTP and OUTN should cross at a 90-degree angle to these signals/supplies.
- OUTP and OUTN should be routed on an outer board layer and away from supply decoupling.
- AVCLK network should not be placed and routed in the proximity of OUTP and OUTN.

**Thermal Considerations**

The use of as much ground plane as possible on the component layer is recommended for the PCB design. The system design should make use of additional heatsinking directly in contact with the MAX5871 to improve the thermal performance. The thermal numbers are based on JEDEC standard 51-12. All the application thermal modeling is required at the system design. A Delphi model is available for system thermal simulation.

**Ordering Information**

PART	TEMP RANGE	PIN-PACKAGE
MAX5871EXE+	-40°C to +85°C	144-FCCSP

+Denotes a lead-free/RoHS-compliant package.

**Package Information**

For the latest package outline information and land patterns (footprints), go to [www.maximintegrated.com/packages](http://www.maximintegrated.com/packages). Note that a "+", "#", or "-" in the package code indicates RoHS status only. Package drawings may show a different suffix character, but the drawing pertains to the package regardless of RoHS status.

PIN-PACKAGE	PACKAGE CODE	OUTLINE NO.	LAND PATTERN NO.
144 FCCSP	X14400F+1	<a href="#">21-0732</a>	—

## Revision History

REVISION NUMBER	REVISION DATE	DESCRIPTION	PAGES CHANGED
0	3/15	Initial release	—
1	7/19	Updated Electrical Characteristics, Pin Description table, Figure 11, DSP configuration table, and MAX5871 Configuration	9, 20, 30, 66, 100–104

For pricing, delivery, and ordering information, please visit Maxim Integrated's online storefront at <https://www.maximintegrated.com/en/storefront/storefront.html>.

*Maxim Integrated cannot assume responsibility for use of any circuitry other than circuitry entirely embodied in a Maxim Integrated product. No circuit patent licenses are implied. Maxim Integrated reserves the right to change the circuitry and specifications without notice at any time. The parametric values (min and max limits) shown in the Electrical Characteristics table are guaranteed. Other parametric values quoted in this data sheet are provided for guidance.*