

1

2

3

4

5

6

7

## Material

- ① Terminal body (metal housing): steel stamped Zinc plating
- ② Terminal screw: Steel Zinc plating "-" slot type
- ③ Contacts: Brass, Tin plated
- ④ Firm wire chunk: steel Zinc plating
- ⑤ Insulator (housing): Thermoplastic (UL94V-0), GREEN

## Electrical cULus

Voltage rating: 300VAC  
Current rating: 20A

Wire range:

Solid wire(AWG): 12-22

Stranded wire(AWG): 12-22

Torque(Lb-In): 2.4

Screw: M2.5

Wire strip length: 10-11mm

Withstanding Voltage: 1.6kV

Operating temperature: -40°C to +115°C

Soldering temperature: 250°C±10°C/5 Sec

Safety Approval:

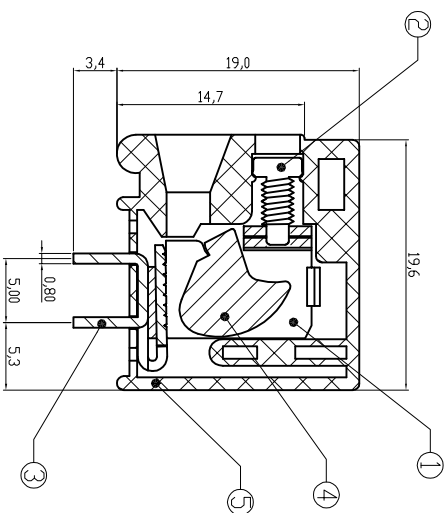
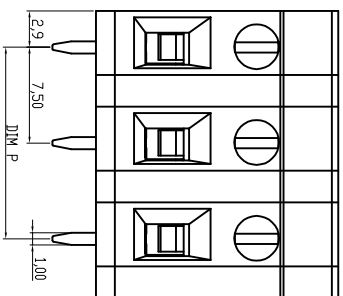
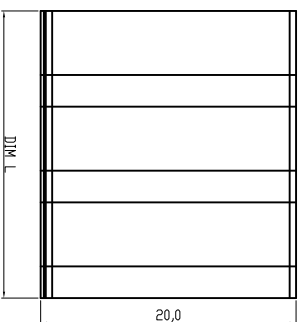

## DIMENSION

L	Nx7.5
P	(N-1)x7.5

N=Number of poles

Poles	Tolerance	
	DIM L	DIM P
2p-6p	±0.20	±0.15
7p-12p	±0.25	±0.20
13p-18p	±0.30	±0.25
19p-24p	±0.40	±0.30

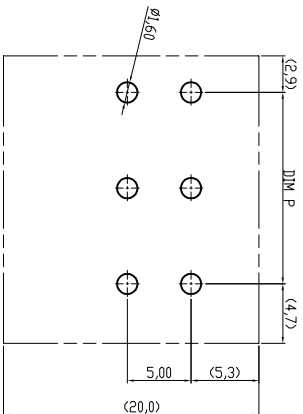

## RECOMMENDER PCB LAYOUT

# RoHS compliant



File No.: E349947

Scale	1:1
TOLERANCE	
X.	±0.50
X.X	±0.30
X.XX	±0.10
DIM	TOL
X.°	±1°
Angle	TOL

①	Add the UL File No.	19.04.2016	Winnie
②	Drawn	19.04.2010	Alex
Id.	Modification	Date	Name

Date	Name	
19.04.2010	Alex	
19.04.2016	Winnie	
Approved	19.04.2016	Winnie

**ASSMANN**  
WSW/ components

Customer-No.  
ASSMANN WSW-No.  
**A-TB750-TRXXH**

Drawing-No.

**ASS 4096 CO** rev01

Replace

Sheet

1

2

3

4

5

6

7

H

G

F

E

D

C

B

A

H

G

F

E

D

C

B

A