



FEATURES

- RoHS compliant
- Site compatible with NM485D
- Single 5V supply
- Thermal shutdown protection
- EIA-485 and CCITT V.10 & V.11 compatible
- Differential driver and receiver
- Driver tri-state outputs active high enable
- Low Profile 24 pin DIL package style
- 1kVrms Isolation
- Thermal shutdown protection

DESCRIPTION

The NM485SLC is a low power electrically isolated differential driver and receiver designed for bi-directional data communication or multipoint bus transmission at rates up to 2.5Mbits per second. The device combines a tri-state differential line driver and a differential input line receiver. The driver and receiver have active high and active low enables, respectively, which can be connected together to function as direction control. The receiver features a high output state when the inputs are left open. Thermal shutdown protection forces the driver into a high impedance state, under line fault conditions. No external components are needed as a single 5V supply powers all functions either side of the isolation boundary. The device is supplied in a low profile 24 pin plastic package.



For full details go to
www.murata-ps.com/rohs

ELECTRICAL CHARACTERISTICS

Parameter	Test conditions	Min.	Typ.	Max.	Units
Supply voltage, V_{CC}		4.75	5.0	5.25	V
Isolated reference voltage, V_{REF}				5.0	V
+ V_{REF} Current	$R_L=54\Omega$			25	mA
High level input voltage, V_{IH}	D ENABLE, R ENABLE and D_{IN}	2.8			V
Low level input voltage, V_{IL}				0.8	V
Common mode output voltage, V_{OC}		-7.0		12	V
High level output current I_{OH}	Driver			-60	mA
Low level output current, I_{OL}				60	mA
Common mode input voltage, V_{IC}				± 12	V
Differential input voltage, V_{ID}				± 12	V
High level output current, I_{OH}	Receiver			-5.0	mA
Low level output current, I_{OL}				25	mA

RECEIVER ELECTRICAL CHARACTERISTICS

Parameter	Test conditions	Min.	Typ.	Max.	Units
High threshold differential input, V_{TH}	$V_{ID}=2.7V, I_{O}=-0.4mA$			0.2	V
Low threshold differential input, V_{TL}	$V_{ID}=0.5V, I_{O}=16mA$	-0.2			V
Input hysteresis, ΔV_I			70		mV
High level output voltage, V_{OH}	$V_{ID}=200mV, I_{OH}=-5.0mA$	2.7			V
Low level output voltage, V_{OL}	$V_{ID}=-200mV, I_{OL}=25mA$			0.8	V
Line input current, I_I	Other input at 0V, $V_I=12V$			1.0	mA
	Other input at 0V, $V_I=-7.0V$			-0.8	mA
Short circuit output current, I_{OS}				85	mA
Input resistance, R_i		12			K Ω

RECEIVER SWITCHING CHARACTERISTICS

Parameter	Test conditions	Min.	Typ.	Max.	Units
Propagation delay time L to H, T_{PLH}	$V_{ID}=-1.5V$ to $1.5V, C_L=15pF$		150	180	ns
Propagation delay time H to L, T_{PHL}			130	150	ns
Output disable time from high level	$C_L=15pF$		90	150	ns
Output disable time from low level	$C_L=15pF$		90	150	ns
Output enable time to high level	$C_L=15pF$		130	150	ns
Output enable time to low level	$C_L=15pF$		80	150	ns

RECEIVER FUNCTION TABLE

Differential inputs A-B	R ENABLE	R_{OUT}
$V_{ID} \geq 0.2V$	Low level	High level
$-0.2V < V_{ID} < +0.2V$	Low level	Undefined
$V_{ID} \leq -0.2V$	Low level	Low level
Irrelevant	High level	High level

ISOLATION CHARACTERISTICS

Parameter	Conditions	Min.	Typ.	Max.	Units
Isolation test voltage	Flash tested for 1 second	1000			Vrms
Isolation capacitance			40		pF

ABSOLUTE MAXIMUM RATINGS

Supply voltage V_{CC} with respect to pin 11	7V
Input voltage D ENABLE, R ENABLE and D_{IN}	7V
Receiver differential input voltage range	-14V to +14V
Output voltage range, driver	-14V to +14V
Power dissipation	1000mW
Data transmission rate	2.5Mbps
Lead temperature 1.5mm from case for 10 seconds	300°C

All data taken at $T_A=25^\circ C, V_{CC}=5V$.

DRIVER ELECTRICAL CHARACTERISTICS					
Parameter	Test conditions	Min.	Typ.	Max.	Units
High level output voltage, V_{OH}	$I_{OH}=-25mA$		3.7		V
Low level output voltage, V_{OL}	$I_{OH}=25mA$		1.1		V
Differential output voltage, V_{OD1}	$I_o=0$	1.5		6.0	V
Differential output voltage, V_{OD2}	$R_L=100\Omega$	2.0			V
	$R_L=54\Omega$	1.5		5.0	V
Change in magnitude of differential output voltage, ΔV_{OD}				± 0.2	V
Common mode output voltage, ΔV_{OC}	$R_L=54\Omega$ or 100Ω	-1.0		3.0	V
Change in magnitude of common mode output voltage, ΔV_{OC}				± 0.2	V
Output current power off, I_o	$V_{CC}=0, V_o=-7.0V$ to $12V$			± 100	μA
High level input current, I_{IH}	$V_{IH}=4.0V$		2.0	20	μA
Low level input current, I_{IL}	$V_{IL}=0.8V$		-8.0	-15	mA
Short circuit output current, I_{OS}	$V_o=-7.0V^1$			-250	mA
	$V_o=12V^1$			250	mA

DRIVER SWITCHING CHARACTERISTICS					
Parameter	Test conditions	Min.	Typ.	Max.	Units
Differential output delay time, T_{DD}	$R_L=54\Omega, C_L=50pF$		20	25	ns
Output disable time from high level, T_{PHZ}	$R_L=110\Omega, C_L=50pF$		70	120	ns
Output disable time from low level, T_{PLZ}	$R_L=110\Omega, C_L=50pF$		60	120	ns
Propagation delay time L to H, T_{PLH}	$R_L=27\Omega, C_L=50pF$		80	150	ns
Propagation delay time H to L, T_{PHL}			80	150	ns
Differential output transition time, T_{TD}	$R_L=54\Omega, C_L=50pF$		150	300	ns
Output enable time to high level, T_{PZH}	$R_L=110\Omega, C_L=50pF$		80	120	ns
Output enable time to low level, T_{PZL}	$R_L=110\Omega, C_L=50pF$		80	120	ns

DRIVER FUNCTION TABLE			
D_{IN}	D ENABLE	D _v Output	D _z Output
High level	High level	High level	Low level
Low level	High level	Low level	High level
Irrelevant	Low level	High impedance	High impedance

TEMPERATURE CHARACTERISTICS				
Parameter	Min.	Typ.	Max.	Units
Operating free-air temperature range	0		70	°C
Storage temperature range	-40		125	°C

RoHS COMPLIANCE INFORMATION	
	<p>This series is compatible with RoHS soldering systems with a peak wave solder temperature of 300°C for 10 seconds. The pin termination finish on this product series is Matte Tin over Nickel Preplate. The series is backward compatible with Sn/Pb soldering systems.</p> <p>For further information, please visit www.murata-ps.com/rohs</p>

1. Duration of short circuit should not exceed 1 second.

APPLICATION NOTES

The increased use of balanced data transmission lines, (distributing data to several system components and peripherals over relatively long lines) has brought about the need for multiple driver/receiver combinations on a single twisted pair line. This resulted in an upgraded version of EIA RS-422, named EIA-485. EIA-485 takes into account EIA RS-422 requirements for balanced line data transmission, and allows for multiple drivers and receivers.

The NM485SLC is a low power isolated differential interface providing EIA-485 compatibility. The use of a differential communications interface such as the NM485SLC allows data transmission at high rates and over long distances to be accomplished. This is because effects of external noise sources and cross talk are much less pronounced on the data signal. Any external noise source coupling onto the differential lines will appear as an extra common mode voltage which the receiver is insensitive to. The difference between the signal levels on the two lines will therefore remain the same. Similarly a change in the local ground potential at one end of the line will appear as just another change in the common mode voltage level of the signals. Twisted pair cable is commonly used for differential communications since its twisted nature tends to cause cancellation of the magnetic fields generated by the current flowing through each wire, thus reducing the effective inductance of the pair.

Computer and industrial serial interfacing are areas where noise can seriously affect the integrity of data transfer, and a proven route to improve noise performance for any interface system is galvanic isolation. Galvanic isolation removes the ground loop currents from data lines and hence the impressed noise voltage which affects the signal is also eliminated. The isolation feature of the NM485SLC also means that common mode noise effects are removed and many forms of radiated noise are reduced to negligible limits.

The NM485SLC has driver thermal shutdown protection which protects the device from line fault conditions. If the outputs of the driver are accidentally shorted to a power supply or low impedance source, up to 250mA can flow through the part. The thermal shutdown circuit disables the driver output when the internal temperature of the I.C. reaches 150°C and turns it back on when the temperature cools to 130°C. If two or more NM485SLCs are used and drivers are shorted directly, the driver outputs can not supply enough current to activate the thermal shutdown. Thus the internal shutdown circuit will not prevent contention faults when two drivers are active on the same bus at the same time.

Figure 1 demonstrates how the differential lines of the NM485SLC can be connected to form a transceiver. Data direction is controlled by the driver enable and receiver enable pins. This means the device can receive when the receiver enable is low and transmit when the driver enable is high. As the driver is active high, to reduce the power dissipation even further, it is advisable to disable the driver when not transmitting data.

Some data encoding schemes require the output of the receiver to maintain a known state, usually a logic 1, when the data transmission is complete and all drivers are forced into three-state, high impedance.

The NM485SLC receiver has a fail safe feature which guarantees the output to be in a logic 1 state when the receiver inputs are left floating (open circuit). However, when the cable is terminated with 120Ω, the differential inputs to the receiver are shorted together, not left floating. Since the receiver has about 70mV hysteresis, the output will maintain the last bit received.

Implementing an isolated LONWORKS (™) network using the NM485SLC

The Echleon LONWORKS (Local Operating Network) network is designed to be used in industrial applications in which other electrical equipment is operated. Often the LON™ will be the method of controlling machinery or sensing machine activity. The environment is therefore likely to be electrically noisy and to reduce the possibility of data corruption, an isolated network communications system is a preferred method of data transfer.

The EIA-485 standard provides a method of achieving multi-point (multi-drop) data transmission over balanced twisted pair transmission lines. The standard is a differential scheme offering a large degree of common mode immunity compared to single ended schemes. The isolated differential method offers the highest common mode and line noise immunity for wire based systems.

The NM485SLC is a fully isolated EIA-485 standard driver and receiver, which requires only a single 5V supply. The device offers full data direction programming and can hence be configured as a transceiver. The NM485SLC can be operated at transmitting or receiving data rates of up to 2.5Mbps, hence is fully compatible with the LONTALK (™) transmission rate standards.

Configuring the NM485SLC as a transceiver

The NM485SLC is configured as a transceiver simply by connecting the inverting R_B receive to the inverting D_Z drive and the non-inverting R_A receive to the non-inverting D_V drive. The data direction is determined by the driver enable pins (D ENABLE and R $\overline{\text{ENABLE}}$), the transceiver acting as a transmitter when the enable pin is high and a receiver when the enable pin is low.

Figure 1

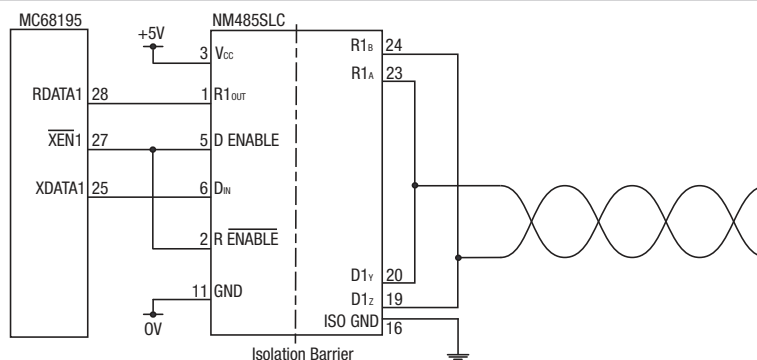

APPLICATION NOTES (continued)

System Performance

The EIA-485 standard allows a maximum of 32 unit loads to be connected to the network, this is less than the LONWORKS standard of 64 nodes. A unit load is any single driver, receiver or transceiver in the EIA-485 standard, or any single node under the LONWORKS scheme. Similarly the EIA-485 standard specifies a maximum data rate standard of 10Mbps, whereas the maximum LONWORKS data rate standard is 1.25Mbps. The resultant maximum system performance for the LONWORKS EIA-485 configuration is therefore 32 nodes at 1.25Mbps. The NM485SLC isolated serial interface device supports this configuration, as well as any lower specified system.

The EIA-485 standard defines the maximum line length as a function of data rate (in Mbps). This implies that the user must choose between the line length of the network and its maximum data transmission rate.

The isolated interface has been used in previous configurations (e.g. NM232D) to increase the available line length as isolated data lines are much less susceptible to ground currents and variations in local supplies. The feature of isolation in a LON environment is intended to be used primarily to improve noise susceptibility, therefore, unless the line length improvements can be reliably demonstrated by the user, the EIA-485 recommendations on maximum cable length are assumed to apply.

The complete hardware implementation for the LONWORKS EIA-485 network is relatively straight forward (see figure 2). There is a minimum of components required, only 1 interface part and one resistor, and the complete LONTALK transmission protocols are supported. The isolation barrier of 1000Vrms offers improved noise immunity compared to a non-isolated system and eliminates node-to-node supply voltage mismatch and possible ground current loops.

Figure 2

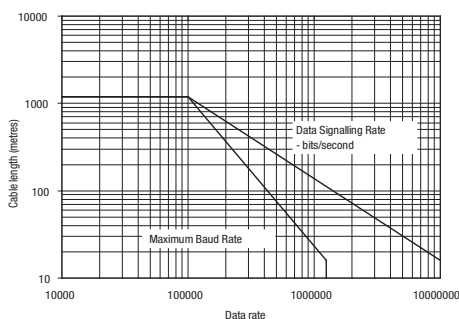
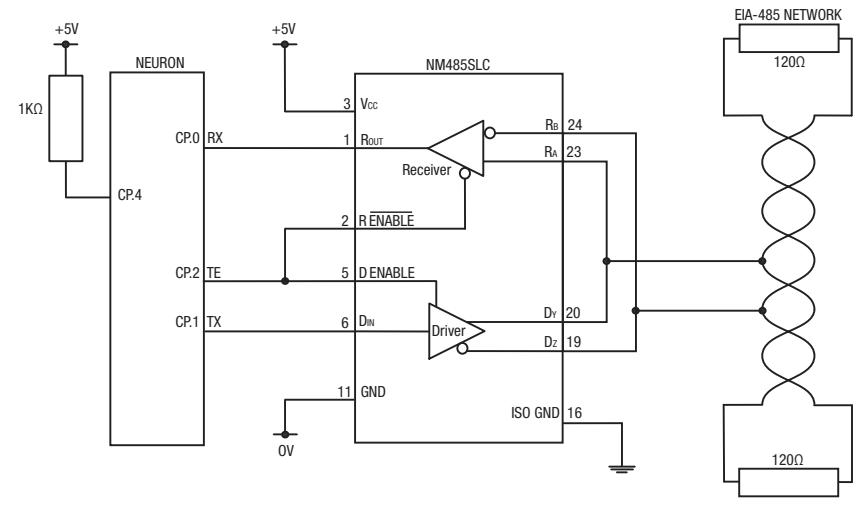

Figure 3



TECHNICAL NOTES

ISOLATION VOLTAGE

'Hi Pot Test', 'Flash Tested', 'Withstand Voltage', 'Proof Voltage', 'Dielectric Withstand Voltage' & 'Isolation Test Voltage' are all terms that relate to the same thing, a test voltage, applied for a specified time, across a component designed to provide electrical isolation, to verify the integrity of that isolation.

Murata Power Solutions NM485SLC series of DC/DC converters are all 100% production tested at their stated isolation voltage. This is 1000Vrms for 1 second.

A question commonly asked is, "What is the continuous voltage that can be applied across the part in normal operation?"

For a part holding no specific agency approvals, such as the NM485SLC series, both input and output should normally be maintained within SELV limits i.e. less than 42.4V peak, or 60VDC. The isolation test voltage represents a measure of immunity to transient voltages and the part should never be used as an element of a safety isolation system. The part could be expected to function correctly with several hundred volts offset applied continuously across the isolation barrier; but then the circuitry on both sides of the barrier must be regarded as operating at an unsafe voltage and further isolation/insulation systems must form a barrier between these circuits and any user-accessible circuitry according to safety standard requirements.

REPEATED HIGH-VOLTAGE ISOLATION TESTING

It is well known that repeated high-voltage isolation testing of a barrier component can actually degrade isolation capability, to a lesser or greater degree depending on materials, construction and environment. The NM485SLC series has toroidal isolation transformers, with no additional insulation between primary and secondary windings of enameled wire. While parts can be expected to withstand several times the stated test voltage, the isolation capability does depend on the wire insulation. Any material, including this enamel (typically polyurethane) is susceptible to eventual chemical degradation when subject to very high applied voltages thus implying that the number of tests should be strictly limited. We therefore strongly advise against repeated high voltage isolation testing, but if it is absolutely required, that the voltage be reduced by 20% from specified test voltage. This consideration equally applies to agency recognized parts rated for better than functional isolation where the wire enamel insulation is always supplemented by a further insulation system of physical spacing or barriers.

PACKAGE SPECIFICATIONS

MECHANICAL DIMENSIONS

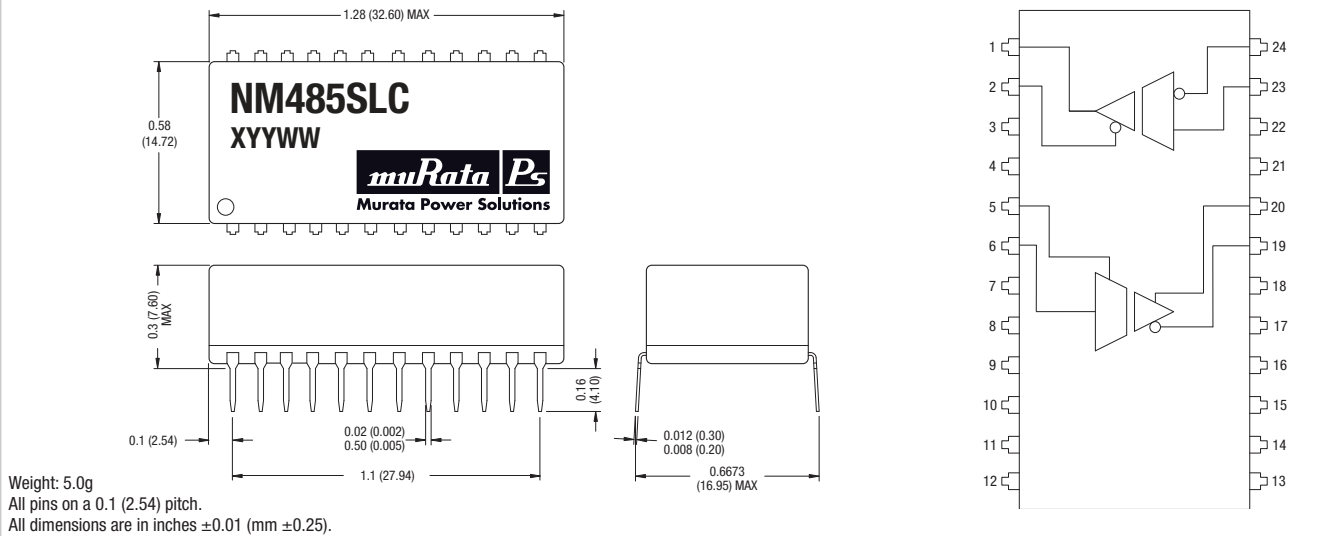

PIN CONNECTIONS

Pin	Function	Description
1	R _{OUT}	Receiver number output TTL logic
2	R _{ENABLE}	Receiver ENABLE (low)
3	V _{CC}	+5V supply
4	NC	No Internal Connection
5	D _{ENABLE}	Driver ENABLE (High)
6	D _{IN}	Driver input TTL logic
7-10	NC	No Internal Connection
11	GND	Ground
12-13	NC	No Internal Connection
14	V _{REF}	Isolated +5V output
15	NC	No Internal Connection
16	ISO GND	Isolated ground
17-18	NC	No Internal Connection
19	D _Z	Driver differential inverting output
20	D _Y	Driver differential non-inverting output
21-22	NC	No Internal Connection
23	R _A	Receiver differential non-inverting input
24	R _B	Receiver differential inverting input

RECOMMENDED FOOTPRINT

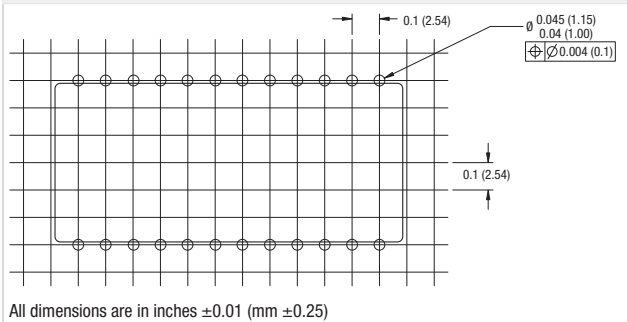

TUBE OUTLINE DIMENSIONS

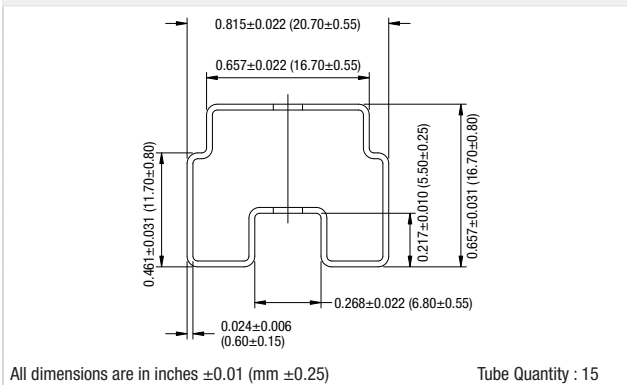

Murata Power Solutions, Inc.
11 Cabot Boulevard, Mansfield, MA 02048-1151 U.S.A.
ISO 9001 and 14001 REGISTERED

**This product is subject to the following [operating requirements](#) and the [Life and Safety Critical Application Sales Policy](#):
Refer to: <http://www.murata-ps.com/requirements/>**

Murata Power Solutions, Inc. makes no representation that the use of its products in the circuits described herein, or the use of other technical information contained herein, will not infringe upon existing or future patent rights. The descriptions contained herein do not imply the granting of licenses to make, use, or sell equipment constructed in accordance therewith. Specifications are subject to change without notice. © 2017 Murata Power Solutions, Inc.