

Integrated Transceiver Modules for Bluetooth® Smart Applications

DESCRIPTION

CEL's MeshConnect Bluetooth® Smart Modules eliminate design risk and significantly reduce time-to-market for Bluetooth Low Energy wireless solutions, including the innovative CSRmesh™ protocol.

These devices are footprint-compatible with CEL's existing line of ZigBee and Thread-based Modules, allowing designers to easily transition between multiple wireless networking standards via drop-in compatible module hardware.

KEY FEATURES

- Best-in-Class RF Range of 50m to 100m
- +8dBm Transmit Power
- Supports CSRMesh™
- Available with Avi-on™ Software
- 15 Analog/Digital I/O Pins
- Supports UART, I2C & SPI

APPLICATIONS

- Connected Home
- Building Automation
- Sports & Fitness Sensors
- Health Sensors
- Mobile Accessories
- General Bluetooth Wireless Sensor Networking



BLOCK DIAGRAM

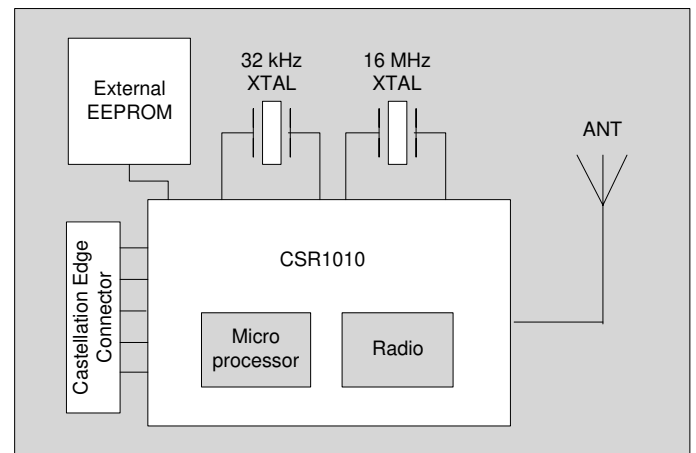

ORDERING INFORMATION

Part Number	Order Number	Description	Min/Multiple
MeshConnect B1010SP0 Mini Modules	B1010SP0-1-R	CSR1010 IC, +8dBm Output Power, PCB Trace Antenna, 512kbit flash	600/600
	B1010SP0-1C-R	CSR1010 IC, +8dBm Output Power, Castellation Pin for External Antenna, 512kbit flash	600/600
	B1010SP0-2-R	CSR1010 IC, +8dBm Output Power, PCB Trace Antenna, 1Mbit flash	600/600
	B1010SP0-2C-R	CSR1010 IC, +8dBm Output Power, Castellation Pin for External Antenna, 1Mbit flash	600/600

DEVELOPMENT KIT

MeshConnect μEnergy Starter Development Kit

CSR's μEnergy platform provides a complete Bluetooth qualified solution for products using the Bluetooth Low Energy standard. CEL's μEnergy Starter Development Kit is a simple yet comprehensive way for designers to develop Bluetooth Smart applications using CSR's μEnergy solution.

Each kit contains:

- Evaluation board with B1010SP0 Mini Module
- CSR μEnergy Platform Software
 - Software Development Kit (SDK) application examples and development tools
 - xIDE for μEnergy (includes compiler)
 - Production test and configuration tools
- Mini-USB Cable
- Setup & Quick Start Guides

Visit <http://meshconnect.cel.com/B1010> for more information.



KIT ORDERING INFORMATION

Kit Family	Order Number	Description	Min/Multiple
MeshConnect μEnergy Starter Development Kit	B1010SP0-EVB-1	μEnergy Starter Development Kit, with license for CSR μEnergy SDK, 512kbit flash memory module	1/1
	B1010SP0-EVB-2	μEnergy Starter Development Kit, with license for CSR μEnergy SDK, 1Mbit flash memory module	1/1

TABLE OF CONTENTS

DESCRIPTION	1
KEY FEATURES.....	1
APPLICATIONS.....	1
BLOCK DIAGRAM.....	1
ORDERING INFORMATION.....	1
DEVELOPMENT KIT.....	2
KIT ORDERING INFORMATION.....	2
TABLE OF CONTENTS	3
TRANSCEIVER IC.....	4
ANTENNA.....	4
EXTERNAL EEPROM.....	4
SOFTWARE / FIRMWARE.....	5
CRYSTAL FREQUENCY TRIM AND BLUETOOTH DEVICE ADDRESS.....	5
ABSOLUTE MAXIMUM RATINGS	7
RECOMMENDED OPERATING CONDITIONS.....	7
DC CHARACTERISTICS	7
RF CHARACTERISTICS.....	8
I/O PIN ASSIGNMENTS	9
ZICM35x ZIGBEE/THREAD MODULE COMPATIBILITY	9
ERRATA.....	10
MODULE DIMENSIONS.....	10
MODULE LAND FOOTPRINT	11
AGENCY CERTIFICATIONS (PCB ANTENNA ONLY).....	14
SHIPMENT, HANDLING AND STORAGE.....	15
QUALITY	15
REFERENCES.....	16
REVISION HISTORY	16
DISCLAIMER	16

TRANSCIVER IC

CEL's MeshConnect B1010SP0 Mini Module, utilizing the CSR1010 transceiver IC, is a single-mode Bluetooth Low Energy (BLE) device that is part of CSR's μ Energy platform. This transceiver incorporates a baseband modem, RF circuitry, and 16-bit XAP microprocessor. Together with CSR's qualified Bluetooth v4.x specification stack, it is an excellent low cost, low power consumption and high performance solution ideally suited for all BLE applications. For more information about the CSR1010 IC, please visit www.csr.com.

ANTENNA

CEL's B1010SP0 Mini Modules include an integrated Printed Circuit Board (PCB) trace antenna. An optional configuration which uses a castellated pin on the module allows the user to connect an external antenna. The B1010SP0 has been certified with the PCB trace antenna only.

The PCB antenna employs a topology that is compact and highly efficient. To maximize range, an adequate ground plane must be provided on the host PCB. Correctly positioned, the ground plane on the host PCB will contribute significantly to the antenna performance (it should not be directly under the module PCB antenna). The position of the module on the host board and overall design of the product enclosure contribute to antenna performance. Poor design affects radiation patterns and can result in reflection, diffraction and/or scattering of the transmitted signal.

For optimum antenna performance, the MeshConnect Mini Modules should be mounted with the PCB trace antenna overhanging the edge of the host board. To further improve performance, a ground plane may be placed on the host board under the module; up to the antenna (a minimum of 1.5" x 1.5" is recommended). The installation of an uninterrupted ground plane on a layer directly beneath the module will also allow you to run traces under this layer. CEL can provide assistance with your PCB layout.

The following are some design guidelines to help ensure antenna performance:

- Never place the ground plane or route copper traces directly underneath the antenna portion of the module
- Never place the antenna close to metallic objects
- In the overall design, ensure that wiring and other components are not placed near the antenna
- Do not place the antenna in a metallic or metalized plastic enclosure
- Keep plastic enclosures 1cm or more away from the antenna in any direction

Under Industry Canada regulations, this radio transmitter may only operate using an antenna of a type and maximum (or lesser) gain approved for the transmitter by Industry Canada. To reduce potential radio interference to other users, the antenna type and its gain should be so chosen that the equivalent isotropically radiated power (e.i.r.p.) is not more than that necessary for successful communication.

Conformément à la réglementation d'Industrie Canada, le présent émetteur radio peut fonctionner avec une antenne d'un type et d'un gain maximal (ou inférieur) approuvé pour l'émetteur par Industrie Canada. Dans le but de réduire les risques de brouillage radioélectrique à l'intention des autres utilisateurs, il faut choisir le type d'antenne et son gain de sorte que la puissance isotrope rayonnée équivalente (p.i.r.e.) ne dépasse pas l'intensité nécessaire à l'établissement d'une communication satisfaisante.

EXTERNAL EEPROM

The B1010SP0 Mini Module incorporates an additional 512kbit or 1Mbit external EEPROM for storing program code and Over-The-Air code updates. The EEPROM is connected to the master I²C interface using I2C_SCL, I2C_SDA, and PIO[2] as detailed in the CSR1010 reference design.

The instruction set for the 512kbit EEPROM is similar to the Fudan FM24C512D. See the [Fudan Microelectronics Group](http://www.fudanmicroelectronics.com) website for more details.

The instruction set for the Atmel AT24CM01-SSHD-T 1Mbit EEPROM is available on [website](http://www.atmel.com).

SOFTWARE / FIRMWARE

CEL's B1010SP0 Mini Modules run CSR's µEnergy platform, which is a fully qualified Bluetooth Low Energy solution. In addition to supporting standard BLE 4.x devices, the B1010SP0 Mini Modules also support CSRmesh, which is a protocol layer that runs on top of the Bluetooth Smart standard that enables messages to be relayed over multiple Bluetooth Smart devices. By expanding the network range through a mesh, comprehensive lighting, home automation, and building automation solutions can easily be developed which can be controlled through a smartphone, tablet, or any other BLE 4.x device.

The CSR µEnergy platform is a feature-rich Bluetooth Smart development environment and contains everything required to create an interoperable BLE 4.x solution. This includes a fully licensed xIDE software development environment (with compiler), example applications for popular Bluetooth Smart and CSRmesh profiles, example host applications for iOS and Android platforms, and production test and configuration tools. For more information, visit www.csr.com.

CRYSTAL FREQUENCY TRIM AND BLUETOOTH DEVICE ADDRESS

During the manufacturing process, all B1010SP0 Mini Modules are tested for full RF and DC functionality. This includes measuring crystal frequency error and setting the crystal frequency trim token so the frequency error for an unmodulated RF tone is as close as possible to zero. At this time a unique Bluetooth Device Address is assigned to each module.

Note: CEL recommends saving the Crystal Frequency Trim value and the Bluetooth Device Address, which is stored in the external EEPROM, before reflashing the B1010SP0 Mini Module with different software. If you accidentally overwrite this information please submit a request to recover them at www.cel.com/MeshConnectHelp.

In order to manually save the crystal frequency trim values or the BDA, install CSR's µEnergy development kit and launch the CSR CsConfig tool while the evaluation board is connected to your PC. This is located under All Programs -> CSR uEnergy -> CSR Tools folder in the Windows start menu. The keys can be exported using CsConfig tool to a .keyr file using Keys -> Export to file and included them into your xIDE project during your application development.

During production, it is recommended to export the keys to a file using the command line version of this tool (csconfigcmd.exe) also present within the development kit. Then flash the application firmware. Finally, merge the key file that was exported previously into the module using the csconfigcmd.exe tool again. For usage information for the command line tool, type csconfigcmd -help located at C:\CSR_uEnergy_SDK-x.x.x.xx\tools\bin at the command prompt.

When the CsConfig tool is first launched, the Connection Options dialog box is displayed. The evaluation board uses the USB SPI transport to communicate with the module. This option should appear if the appropriate drivers were installed during the development kit installation procedure. Once it is selected, click OK.

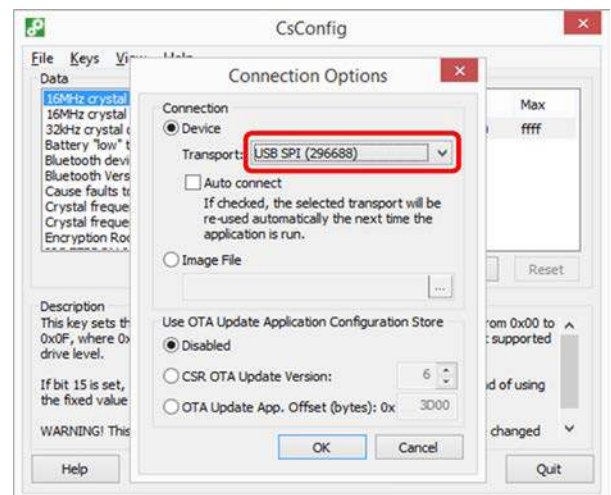

All the key names are now displayed in the left list and their corresponding values are in the right list. The crystal trim value is named "Crystal frequency trim". In the example shown to the right, the value is 0x0015 (21 decimal).

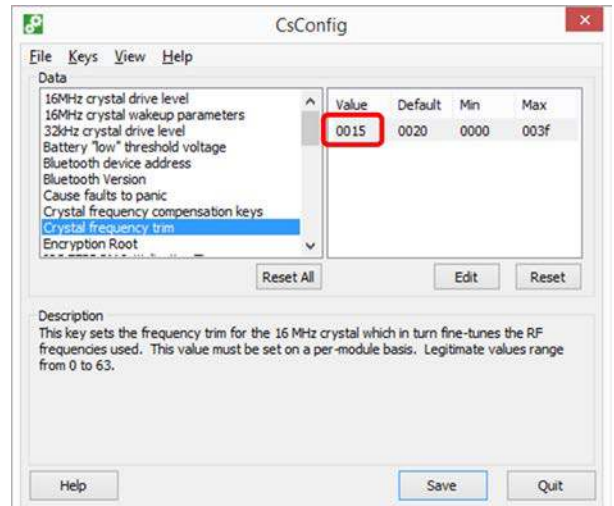

The bluetooth device address (BDA) can also be found the same way. In the example shown to the right, the BDA is 0022A30000AC (read 4 bytes at a time from bottom to top).

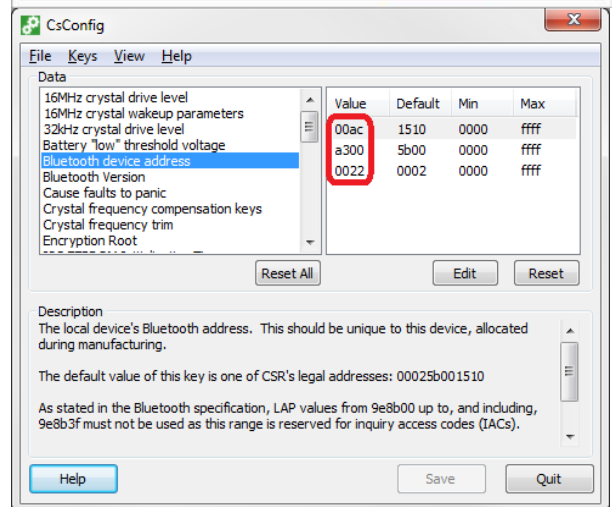

ABSOLUTE MAXIMUM RATINGS

Description	Min	Max	Unit
Storage temperature range	-40	85	°C
Power supply voltage (VDD)	1.8	4.4	V
I/O supply voltage	-0.4	4.4	V
Other terminal voltage*	VSS - 0.4	VDD + 0.4	V

* VDD = Terminal Supply Domain

RECOMMENDED OPERATING CONDITIONS

Description	Min	Typ	Max	Unit
Operating temperature range	-30	-	85	°C
Power supply voltage (VDD)	1.8	-	3.6	V

DC CHARACTERISTICS

(@25°C unless otherwise specified)

Description	Conditions	Min	Typ	Max	Unit
Transmitter Current Draw, max output power	@ 2.7V	-	35	-	mA
	@ 1.8V	-	54	-	mA
	@ 3.6V	-	25	-	mA
Transmitter Current Draw @ 0dBm	@ 2.7V	-	23	-	mA
	@ 1.8V	-	39	-	mA
	@ 3.6V	-	17	-	mA
Receiver Current Draw	@ 2.7V	-	24	-	mA
	@ 1.8V	-	39	-	mA
	@ 3.6V	-	17	-	mA
Sleep mode current (Dormant mode)	@ 3.3V	-	0.9	-	μA

RF CHARACTERISTICS

(@25°C unless otherwise specified)

Path	Description	Conditions	Min	Typ	Max	Unit	
	Operating Frequency		2402		2480	MHz	
TX	Maximum output power		-	8	-	dBm	
	2nd Harmonic		-	-	54	dBuV	
	3rd Harmonic		-	-	54	dBuV	
	In-band emissions	$F = F_0 \pm 2\text{MHz}$		-	-38	-	dBm
		$F = F_0 \pm 3\text{MHz}$		-	-38	-	dBm
		$F = F_0 \pm > 3\text{MHz}$		-	-38	-	dBm
	Modulation delta F1 average		225	255	275	kHz	
	Modulation delta F1 / F2		0.8	-	-	-	
	Modulation delta F2 max		-	100	-	%	
	Frequency accuracy		-100	25	100	kHz	
Frequency offset		-100	25	100	kHz		
	Maximum Drift Rate (kHz/50µs)		-20	8	20	kHz / 50µs	
RX	Receiver Sensitivity			-94		dBm	
	Receiver Sensitivity (with dirty transmitter)			-93		dBm	
	Maximum received signal at 30.8% PER			-10	≥ -10	dBm	

I/O PIN ASSIGNMENTS

Refer to the CSR1010 datasheet for pin functionality details.

Module Pin Number	CSR1010 IC Pin Number	Pin Name	Notes
1, 2, 12, 31, 33	33 to 48	GND	
3, 4, 5, 6, 16, 17, 18, 26	NC	NC	
7	4	WAKE	
8	23	PIO[9]	
9	24	PIO[10]	
10	16	PIO[3]	
11	29	I2C_SDA	Connects internally to SDA on the onboard serial flash.
13	1, 21, 32	VDD	Input power to the module.
14	28	I2C_SCL	Connects internally to SCL on the onboard serial flash.
15	17	PIO[4]	
19	14	PIO[0] / UART_TX	Programmable I/O line or UART TX
20	15	PIO[1] / UART_RX	Programmable I/O line or UART RX
21	26	SPI_PIO#	Selects SPI debug on PIO[8:5]
22	19	PIO[6]	Programmable I/O line or debug SPI chip select
23	20	PIO[7]	Programmable I/O line or debug SPI MOSI
24	22	PIO[8]	Programmable I/O line or debug SPI MISO
25	13	AIO[0]	
27	18	PIO[5]	Programmable I/O line or debug SPI CLK
28	12	AIO[1]	
29	25	PIO[11]	
30	11	AIO[2]	
32	NC	RF OUT	Castellation Pin for External Antenna

ZICM35x ZIGBEE/THREAD MODULE COMPATIBILITY

The geometry of the land pattern and location of the RF castellation is identical to the ZICM35x family of ZigBee/Thread modules. The compatible digital and analog I/O are described below:

Description	ZICM35x	B1010SP0	Notes
Serial Controller 1	UART / SPI / I2C	UART / SPI / I2C	Castellation pins 8,9,19,20
Serial Controller 2	SPI/I2C	I2C	Castellation pins 10,11,14,15
GPIO	PC2	PIO[6]	
GPIO	PC3	PIO[7]	
GPIO	PC4	PIO[8]	
GPIO	PC0	PIO[5]	
GPIO	PB6	PIO[11]	
GPIO	PA7	WAKE	This line can only be used to wake the B1010SP0 from sleep.
Programming	JTCK	SPI_PIO#	Driving this line high on B1010SP0 converts PIO[5,6,7,8] to the SPI programming port.
ADC	PB0, PB5, PB7	AIO[0], AIO[2], AIO[1]	B1010SP0 lines can also be configured as a DAC.

ERRATA

Modules with lot codes earlier than 1530x had different I/O assignments on some of the castellations. The following table summarizes the differences:

Signal Name	Module Pin Number Before 1530x	Module Pin Number After 1530x
SPI_PIO#	3	21
PIO[9]	18	8
PIO[10]	21	9

The changes were made to improve compatibility with the ZICM35x series of ZigBee®/Thread modules.

MODULE DIMENSIONS

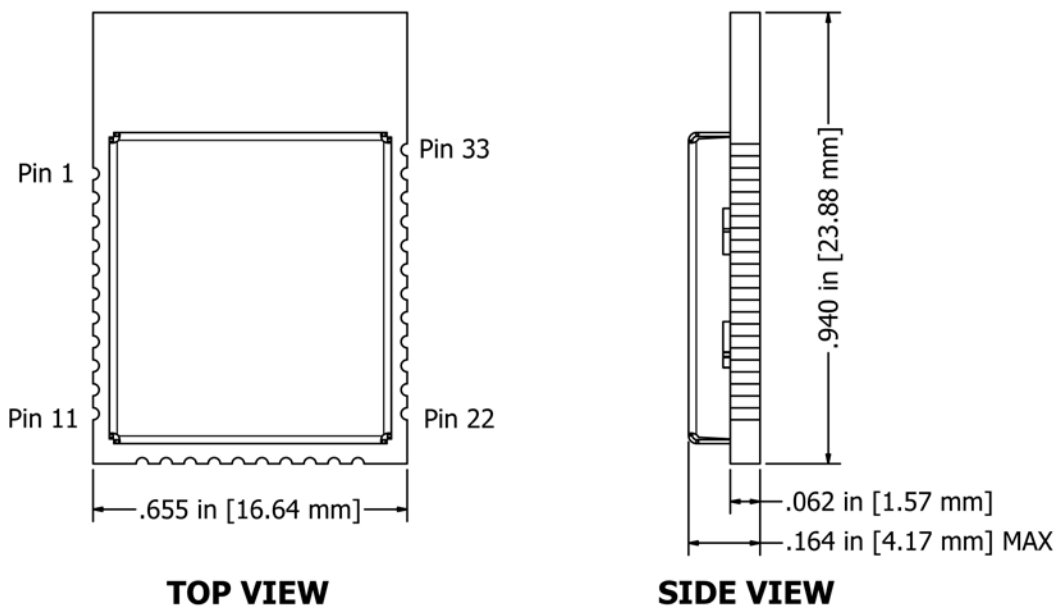

Note: All dimensions are $\pm .005 \text{ in } [0.12 \text{ mm}]$ unless otherwise specified

MODULE LAND FOOTPRINT

Dimensions are shown in inches, with millimeter conversion in brackets

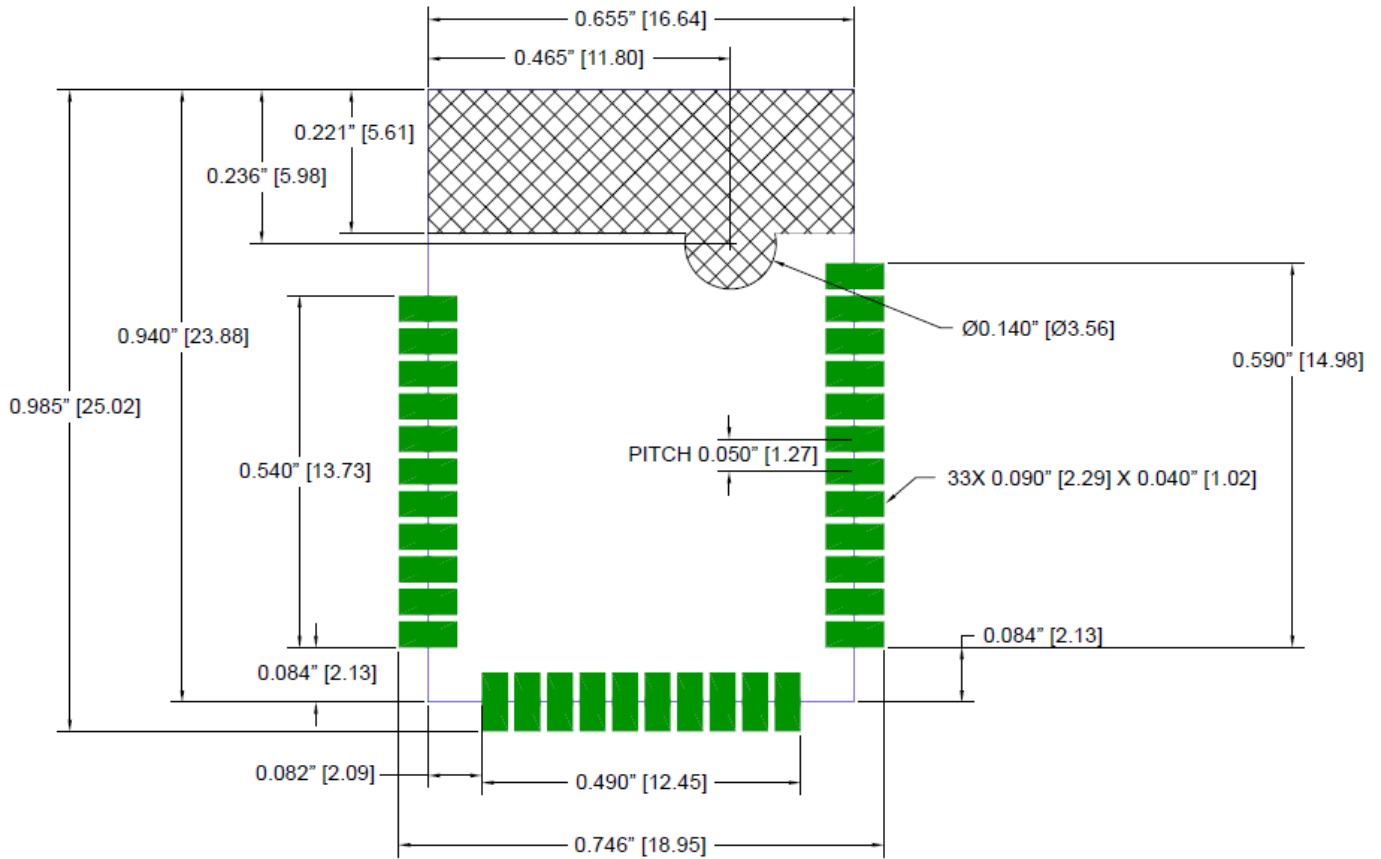

Note: Refer to the Antenna section in this document for layout recommendations which will yield optimal antenna performance.

PROCESSING

Recommended Reflow Profile

Parameter Values	
Ramp Up Rate (from $T_{soakmax}$ to T_{peak})	3°/sec max
Minimum Soak Temperature	150°C
Maximum Soak Temperature	200°C
Soak Time	60-120 sec
$T_{Liquidus}$	217°C
Time above TL	60-150 sec
T_{peak}	250°C
Time within 5° of T_{peak}	20-30 sec
Time from 25° to T_{peak}	8 min max
Ramp Down Rate	6°C/sec max

Pb-Free Solder Paste

Use of “No Clean” soldering paste is strongly recommended, as it does not require cleaning after the soldering process.

Note: *The quality of solder joints on the castellations (“half vias”) where they contact the host board should meet the appropriate IPC Specification. See the Castellated Terminations Section in the latest IPC-A-610 Acceptability of Electronic Assemblies document.*

Cleaning

In general, cleaning the populated module is strongly discouraged. Residuals under the module cannot be easily removed with any cleaning process.

- Cleaning with water can lead to capillary effects where water is absorbed into the gap between the host board and the module. The combination of soldering flux residuals and encapsulated water could lead to short circuits between neighboring pads. Water could also damage any stickers or labels.
- Cleaning with alcohol or a similar organic solvent will likely flood soldering flux residuals into the two housings, which is not accessible for post-washing inspection. The solvent could also damage any stickers or labels.
- Ultrasonic cleaning could damage the module permanently.

The best approach is to consider using a “No Clean” solder paste and eliminate the post-soldering cleaning step.

Optical Inspection

After soldering the module to the host board, consider optical inspection to check the following:

- Proper alignment and centering of the module over the pads
- Proper solder joints on all pads
- Excessive solder or contacts to neighboring pads or vias

Repeating Reflow Soldering

Only a single reflow soldering process is encouraged for host boards.

Wave Soldering

If a wave soldering process is required on the host boards due to the presence of leaded components, only a single wave soldering process is encouraged.

Hand Soldering

Hand soldering is possible. When using a soldering iron, follow IPC recommendations.(reference document *IPC-7711*).

Rework

The MeshConnect Module can be unsoldered from the host board. Use of a hot air rework tool should be programmable and the solder joint and module should not exceed the maximum peak reflow temperature of 250°C.

Caution

If temperature ramps exceed the reflow temperature profile, module and component damage may occur due to thermal shock. Avoid overheating.

Warning

Never attempt a rework on the module itself (i.e., replacing individual components); such actions will terminate warranty coverage.

Additional Grounding

Attempts to improve the module or the system grounding by soldering braids, wires or cables onto the module RF shield cover is done at the customer's own risk. The ground pins at the module perimeter should be sufficient for optimum immunity to external RF interference.

AGENCY CERTIFICATIONS (PCB ANTENNA ONLY)

The following certifications are in effect:

- B1010SP0: FCC and IC

FCC Compliance Statement Part 15.19, Section 7.15 of RSS-GEN

This device complies with Part 15 of the FCC Rules and with Industry Canada license-exempt RSS Standards. Operation is subject to the following two conditions:

1. This device may not cause harmful interference.
2. This device must accept any interference received, including interference that may cause undesired operation.

Le présent appareil est conforme aux CNR d'Industrie Canada applicables aux appareils radio exempts de licence. L'exploitation est autorisée aux deux conditions suivantes:

1. l'appareil ne doit pas produire de brouillage, et
2. l'utilisateur de l'appareil doit accepter tout brouillage radioélectrique subi, même si le brouillage est susceptible d'en compromettre le fonctionnement.

Warning (Part 15.21)

Changes or modifications not expressly approved by CEL could void the user's authority to operate the equipment.

20 cm Separation Distance

To comply with FCC/IC RF exposure limits for general population/uncontrolled exposure, the antenna(s) used for this transmitter must be installed to provide a separation distance of at least 20 cm from all persons and must not be co-located or operating in conjunction with any other antenna or transmitter.

OEM Responsibility to the FCC and IC Rules and Regulations

The MeshConnect Mini Module has been certified per FCC Part 15 Rules and to Industry Canada license-exempt RSS Standards for integration into products without further testing or certification. To fulfill the FCC and IC Certification requirements, the OEM of the MeshConnect Module must ensure that the information provided on the MeshConnect label is placed on the outside of the final product. The MeshConnect Mini Module is labeled with its own FCC ID Number and IC ID Number. If the FCC ID and the IC ID are not visible when the module is installed inside another device, then the outside of the device into which the module is installed must also display a label referring to the enclosed module. The exterior label can use wording such as the following:

"Contains Transmitter Module FCC ID: W7Z-B1010SP0" or "Contains FCC ID: W7Z-B1010SP0"

"Contains Transmitter Module IC: 8254A-B1010SP0" or "Contains IC: 8254A-B1010SP0"

The OEM of the MeshConnect Mini Module may only use the approved antenna (PCB trace antenna) that has been certified with this module. The OEM of the MeshConnect Mini Module must test their final product configuration to comply with Unintentional Radiator Limits before declaring FCC Compliance per Part 15 of the FCC Rules.

IC Certification — Industry Canada Statement

The term "IC" before the certification/registration number only signifies that the Industry Canada technical specifications were met.

Certification IC - Déclaration d'Industrie Canada

Le terme "IC" devant le numéro de certification/d'enregistrement signifie seulement que les spécifications techniques Industrie Canada ont été respectées.

Section 14 of RSS-210

The installer of this radio equipment must ensure that the antenna is located or pointed such that it does not emit RF field in excess of Health Canada limits for the general population. Consult Safety Code 6, obtainable from Health Canada's website: <http://www.hc-sc.gc.ca/ewh-semt/pubs/radiation/99ehd-dhm237/index-eng.php>

L'article 14 du CNR-210

Le programme d'installation de cet équipement radio doit s'assurer que l'antenne est située ou orientée de telle sorte qu'il ne pas émettre de champ RF au-delà des limites de Santé Canada pour la population générale. Consulter le Code de sécurité 6, disponible sur le site Web de Santé Canada: <http://www.hc-sc.gc.ca/ewh-semt/pubs/radiation/99ehd-dhm237/index-eng.php>

SHIPMENT, HANDLING AND STORAGE

Shipment

The MeshConnect Modules are delivered in tape and reel. The reel diameter is 12.992" (330mm) and contains 600 modules.

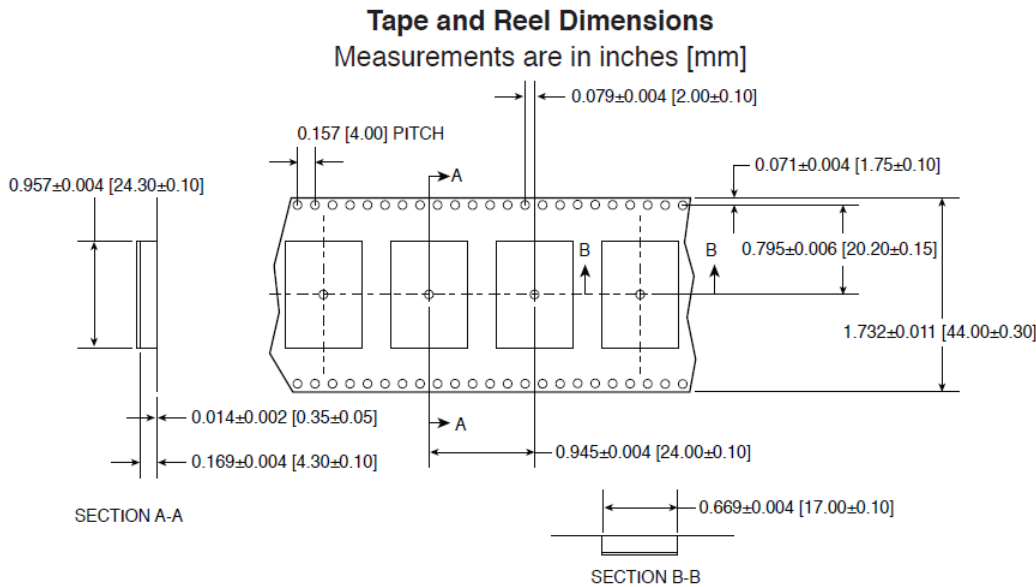

Handling

The MeshConnect Modules are designed and packaged to be processed in an automated assembly line.

Warning

The MeshConnect Modules contain highly sensitive electronic circuitry. Handling without proper ESD protection may destroy or damage the module permanently.

Warning

The MeshConnect Modules are moisture-sensitive devices. Appropriate handling instructions and precautions are summarized in J-STD-033. Read carefully to prevent permanent damage due to moisture intake.

Moisture Sensitivity Level (MSL)

MSL 3, per J-STD-033

Storage

Storage/shelf life in sealed bags is 12 months at <40°C and <90% relative humidity.

QUALITY

CEL Modules offer the highest quality at competitive prices. Our modules are manufactured in compliance with the IPC-A-610 specification, Class II. Our modules go through JESD22 qualification processes which includes high temperature operating life tests, mechanical shock, temperature cycling, humidity and reflow testing. CEL conducts RF and DC factory testing on 100% of all production parts.

CEL builds the quality into our products, giving our customers confidence when integrating our products into their systems.

REFERENCES

Reference Documents	Download
MeshConnect μ Energy Starter Development Kit	Link
CS-231985-DS - <i>CSR1010 Data Sheet</i>	Link
Fudan Microelectronics Group	Link
Health Canada Safety Code 6	Link

REVISION HISTORY

Previous Versions	Changes to Current Version	Page(s)
0019-00-07-00-000 (Issue A) May 15, 2015	Initial Preliminary Data Sheet	N/A
0019-00-07-00-000 (Issue B) July 16, 2015	Added Errata, corrected pin assignments, and added 0dBm current drain information	7, 9, 10
0019-00-07-00-000 (Issue C) October 21, 2015	Clarified Crystal Frequency Trim and Bluetooth Device Address procedure	5, 6
0019-00-07-00-000 (Issue D) March 29, 2015	Added 1Mbit flash memory part, ordering information	1, 2, 4

DISCLAIMER

The information in this document is current as of the published date. The information is subject to change without notice. For actual design-in, refer to the latest publications of CEL Data Sheets or Data Books, etc., for the most up-to-date specifications of CEL products. Not all products and/or types are available in every country. Please check with a CEL sales representative for availability and additional information.

No part of this document may be copied or reproduced in any form or by any means without the prior written consent of CEL. CEL assumes no responsibility for any errors that may appear in this document.

CEL does not assume any liability for infringement of patents, copyrights or other intellectual property rights of third parties by or arising from the use of CEL products listed in this document or any other liability arising from the use of such products. No license, express, implied or otherwise, is granted under any patents, copyrights or other intellectual property rights of CEL or others.

Descriptions of circuits, software and other related information in this document are provided for illustrative purposes in semiconductor product operation and application examples. The incorporation of these circuits, software and information in the design of a customer's equipment shall be done under the full responsibility of the customer. CEL assumes no responsibility for any losses incurred by customers or third parties arising from the use of these circuits, software and information.

FOR MORE INFORMATION

For more information about CEL MeshConnect products and solutions, visit our website at www.cel.com/MeshConnect.

TECHNICAL ASSISTANCE

For Technical Assistance, visit www.cel.com/MeshConnectHelp