

CONNECTION DIAGRAM:

IMPORTANT NOTE:

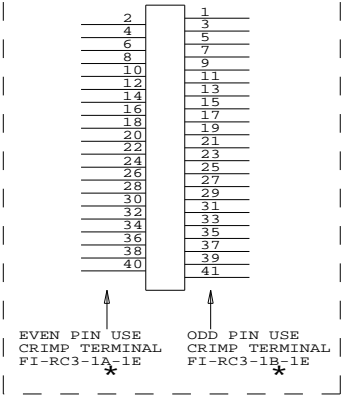

CN2	
1	A-SHIELD
2	A-HPD
3	A-VCC
4	A-DDC/CEC GND
5	A-I2C SDA
6	A-I2C SCL
7	A-RSV
8	A-CEC
9	A-CLK-
10	A-GND4
11	A-CLK+
12	A-D0-
13	A-GND3
14	A-D0+
15	A-D1-
16	A-GND2
17	A-D1+
18	A-D2-
19	A-GND1
20	A-D2+
21	X
22	B-HPD
23	B-VCC
24	B-DDC/CEC GND
25	B-I2C SDA
26	B-I2C SCL
27	B-RSV
28	B-CEC
29	B-CLK-
30	B-GND4
31	B-CLK+
32	B-D0-
33	B-GND3
34	B-D0+
35	B-D1-
36	B-GND2
37	B-D1+
38	B-D2-
39	B-GND1
40	B-D2+
41	B-SHIELD

FI-RE41HL

CABLE TWISTED PAIR ASSIGNMENT  
X=A OR B

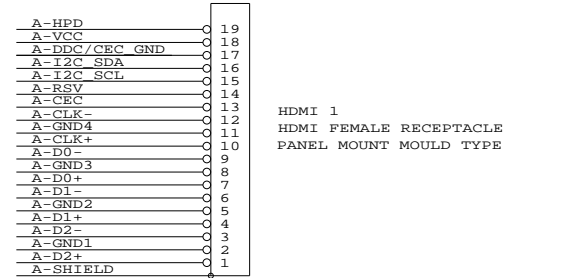
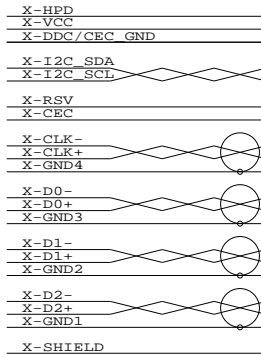

HDMI 1  
HDMI FEMALE RECEPTACLE  
PANEL MOUNT MOULD TYPE

SOLDER TO SHELL OF HDMI 1

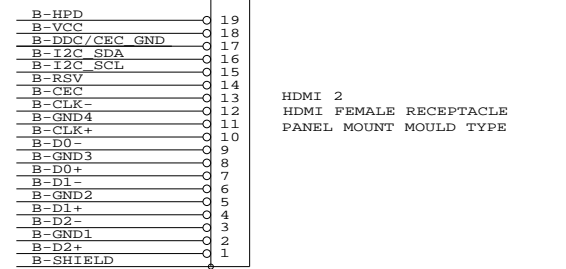

HDMI 2  
HDMI FEMALE RECEPTACLE  
PANEL MOUNT MOULD TYPE

SOLDER TO SHELL OF HDMI 2

CONTROLLER SIDE

CONSTRUCTION DIAGRAM:

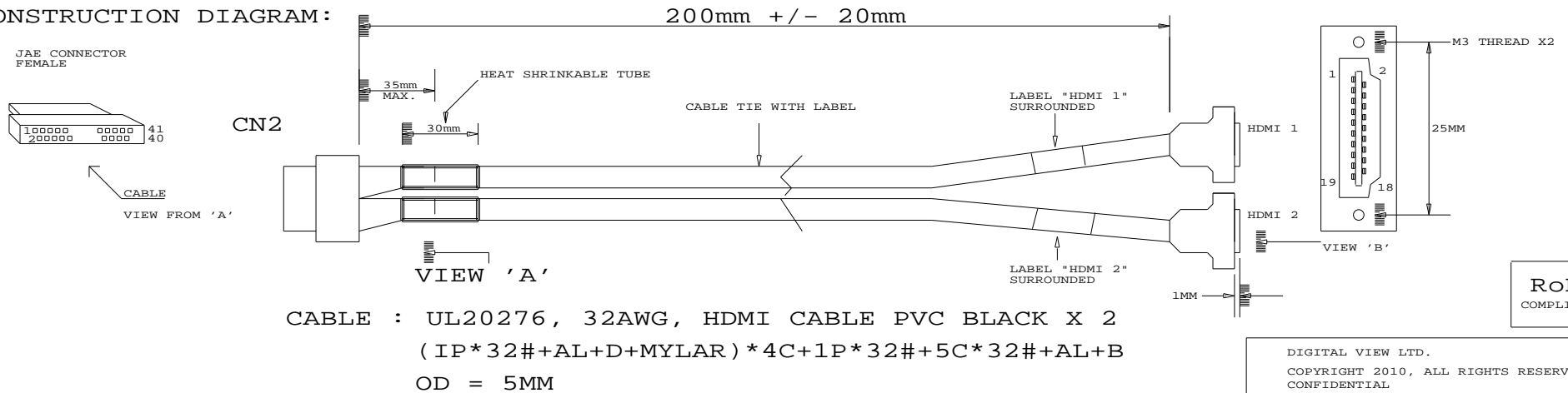

P/N 426300900-3

DUAL HDMI INPUT CABLE, 200MM

DIGITAL VIEW LTD. COPYRIGHT 2010, ALL RIGHTS RESERVED CONFIDENTIAL DRAWN BY: VICTOR NG		
Title	DUAL HDMI INPUT CABLE	
Size	Document Number	REV
B	(...\DV\DV_CABLE\C6300900.SCH)	00
Date:	November 15, 2010	Sheet 1 of 1