

THIS DRAWING IS UNPUBLISHED. RELEASED FOR PUBLICATION
 © COPYRIGHT - By - ALL RIGHTS RESERVED.

REVISIONS				
P	LTR	DESCRIPTION	DATE	APVD
T2		REVISED PER ECO-16-004223	05AUG2016	NK MZ

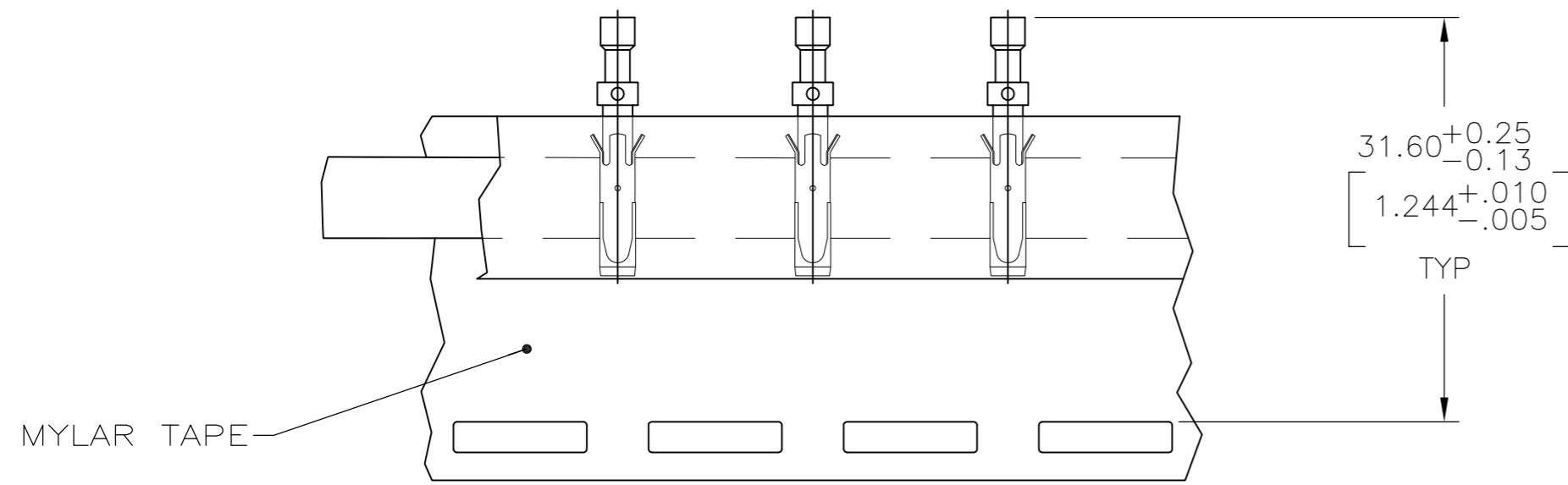
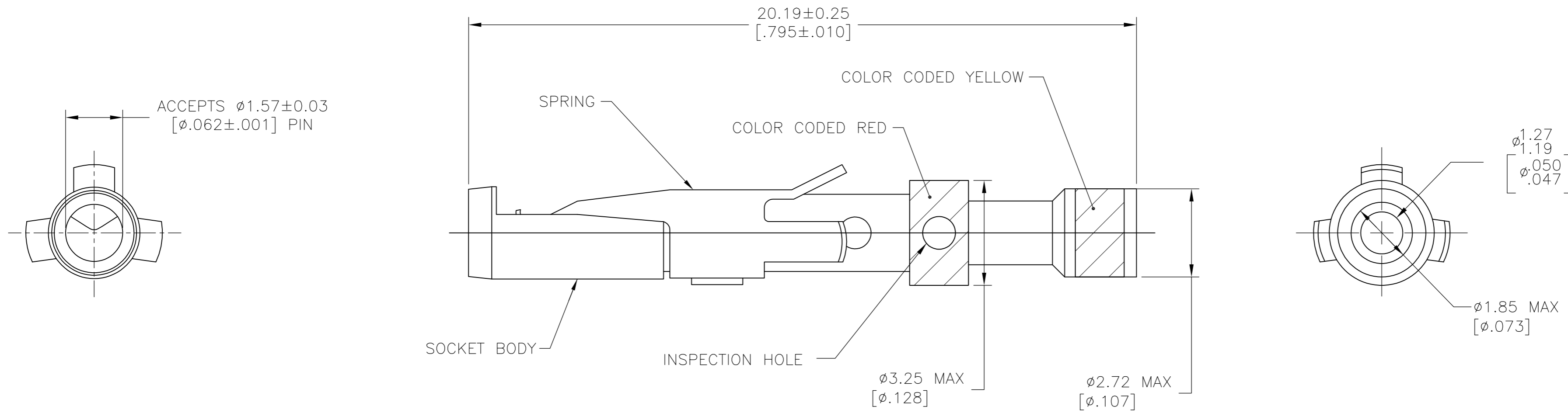

TAPE MTG DETAIL
SCALE 2:1

- ① 0.76 μm [.000030] MIN GOLD OVER 1.27 μm [.000050] MIN NICKEL.
- ② 2.54 μm [.000100] MIN GOLD OVER 1.27 μm [.000050] MIN NICKEL.
- ③ WHEN ORDERING CONTACT ASSEMBLY ON TAPE, ORDER BY THE TAPE NUMBER PLUS THE PACKAGING CODE AS FOLLOWS:
 1. FOR USE WITH AMP TAPETRONIC, PNEUMATIC TOOL-
A. 1000 PARTS TO A BOX ADD PACKAGING CODE: 1MBOX
 2. FOR USE WITH 4/8 INDENT STRIPPER CRIMPER-
A. 1000 PARTS TO A REEL ADD PACKAGING CODE: 1MREEL
B. 5000 PARTS TO A REEL ADD PACKAGING CODE: 5MREEL
- ④ OBSOLETE PARTS: OBSOLETE CIS STREAMLINING PER D.RENAUD/D.SINISI

④ OBSOLETE	SMALL PACK	①	-201580-9-
	TAPE MTG (SEE DETAIL)	②	-201580-7-
OBSOLETE	TAPE MTG (SEE DETAIL)	③	-201580-4-
	STANDARD	②	-201580-3-
	STANDARD	①	201580-1
	PACKAGING TYPE	SOCKET BODY FINISH	PART NUMBER

THIS DRAWING IS A CONTROLLED DOCUMENT.		DWN D.GELTZ 04/07/93	TE Connectivity													
DIMENSIONS: mm [INCHES]		CHK R.STONE 4-26-93														
TOLERANCES UNLESS OTHERWISE SPECIFIED:		APVD R.S.KLINE 4-29-93	NAME CONTACT ASSEMBLY, SOCKET, #16, 20-24 AWG, TYPE II													
<table border="0"> <tr><td>0 PLC</td><td>± -</td></tr> <tr><td>1 PLC</td><td>± -</td></tr> <tr><td>2 PLC</td><td>± -</td></tr> <tr><td>3 PLC</td><td>± -</td></tr> <tr><td>4 PLC</td><td>± -</td></tr> <tr><td>ANGLES</td><td>± -</td></tr> </table>		0 PLC	± -	1 PLC	± -	2 PLC	± -	3 PLC	± -	4 PLC	± -	ANGLES	± -	PRODUCT SPEC -	SIZE A2	CAGE CODE 00779
0 PLC	± -															
1 PLC	± -															
2 PLC	± -															
3 PLC	± -															
4 PLC	± -															
ANGLES	± -															
MATERIAL SOCKET BODY: COPPER ALLOY SPRING: STAINLESS STEEL		FINISH SOCKET BODY: SEE TABLE	WEIGHT -	DRAWING NO C=201580												
CUSTOMER DRAWING			SCALE 10:1	SHEET 1 OF 1												
			RESTRICTED TO -	REV T2												