

DO NOT SCALE FROM THIS PRINT

DESIGNED & DIMENSIONED IN INCHES[MILLIMETERS]

PRF04-P-C-EP-210A-SS

SERIES
-04: TNCA

GENDER
-P: PLUG

TYPE
-C: CABLE

TERMINATION
-S: SOLDER CLAMP

ORIENTATION
-S: STRAIGHT

CABLE TYPE
-210A: MICRO-COAX UFA210A

FINISH
-EP: 50µ" EXTRA HEAVY GOLD CENTER CONTACT, PASSIVATED OUTER CONTACT

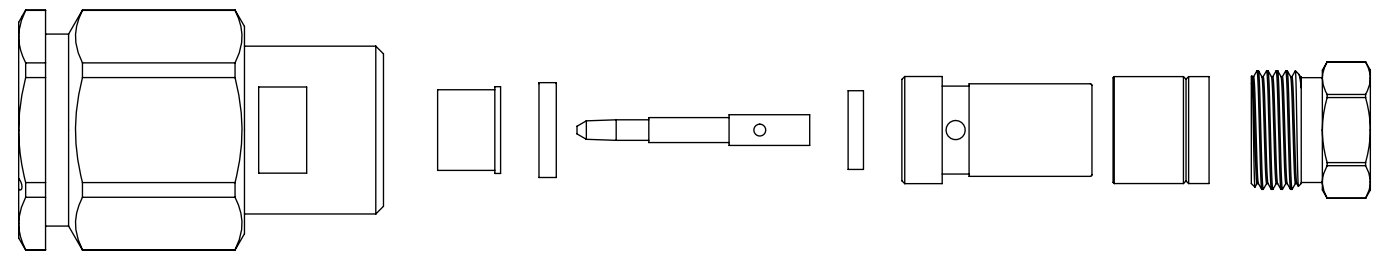
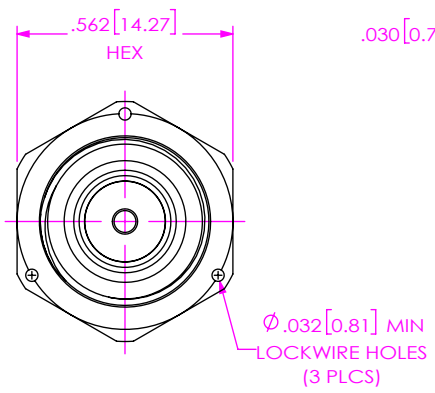
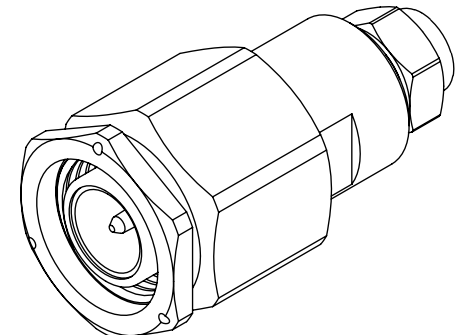
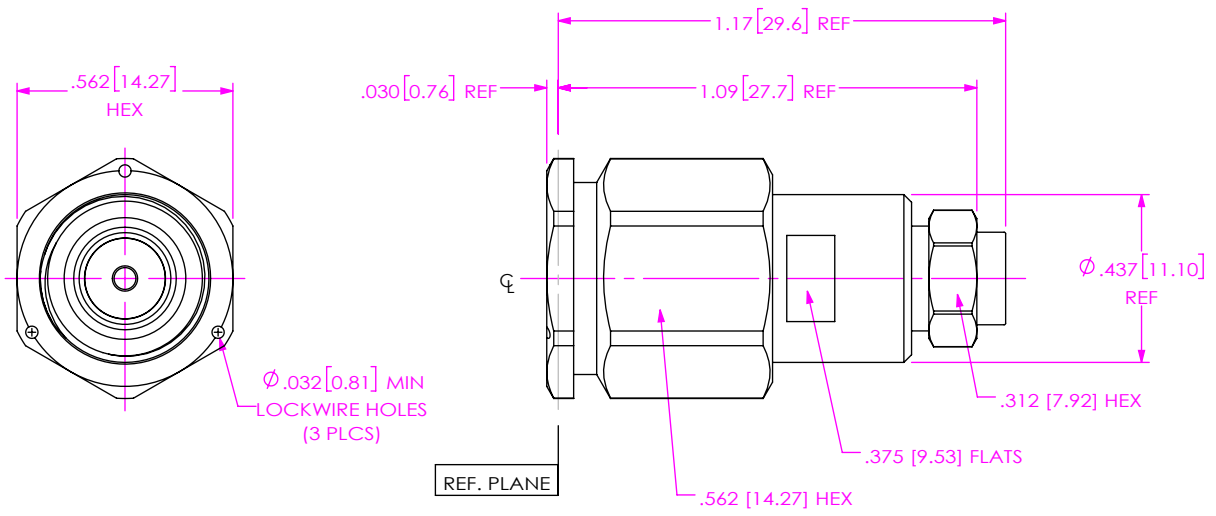

EXPLODED VIEW
NOT TO SCALE
(FOR CLARITY ONLY)

- NOTES:
- MATERIAL:
BODY, COUPLING NUT, BUSHING & CLAMP NUT: STAINLESS STEEL.
CONTACT & LOCK RING: BERYLLIUM COPPER.
SOLDER FERRULE: BRASS.
GASKET: SILICONE RUBBER
INSULATOR: PTFE.
DIELECTRIC STOP, FORWARD BEAD: ULTEM 1000.
 - FINISH:
BODY, COUPLING NUT, BUSHING & CLAMP NUT: PASSIVATED.
SOLDER FERRULE, CONTACT: GOLD OVER NICKEL PLATE,
50 µIN MIN GOLD OVER 50 µIN MIN NICKEL.
 - PCI P/N: 3542.

UNLESS OTHERWISE SPECIFIED, DIMENSIONS ARE IN INCHES. TOLERANCES ARE: DECIMALS ANGLES .XX: ±.01 [0.3] 1° .XXX: ±.005 [0.13] .XXXX: ±.0005 [0.013]	* PROPRIETARY NOTE * THIS DOCUMENT CONTAINS CONFIDENTIAL AND PROPRIETARY INFORMATION AND ALL DESIGN, MANUFACTURING, REPRODUCTION, USE, PATENT RIGHTS AND SALES RIGHTS ARE EXPRESSLY RESERVED BY SAMTEC, INC. THIS DOCUMENT SHALL NOT BE DISCLOSED, IN WHOLE OR PART, TO ANY UNAUTHORIZED PERSON OR ENTITY NOR REPRODUCED, TRANSFERRED OR INCORPORATED IN ANY OTHER PROJECT IN ANY MANNER WITHOUT THE EXPRESS WRITTEN CONSENT OF SAMTEC, INC.	 520 PARK EAST BLVD, NEW ALBANY, IN 47150 PHONE: 812-944-6733 FAX: 812-948-5047 e-Mail: info@SAMTEC.com code 55322	
		DO NOT SCALE DRAWING SHEET SCALE: 2:1	DESCRIPTION: TNCA PLUG, SOLDER CLAMP FOR MICRO-COAX UFA210A CABLE
		DWG. NO. PRF04-P-C-EP-210A-SS	
		BY: EVE L 11/20/2020 SHEET 1 OF 3	

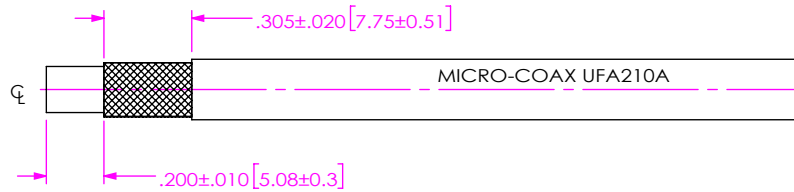

1A. TRIM CABLE TO EXPOSE OUTER BRAID AND DIELECTRIC AS SHOWN.

IN-PROCESS 1

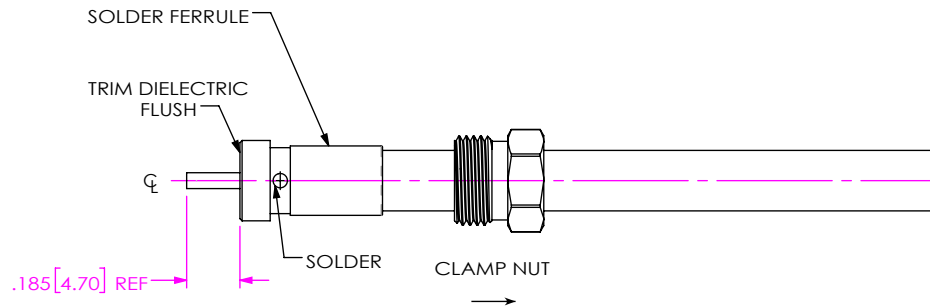

- 2A. SLIDE CLAMP NUT OVER CABLE AS SHOWN.
- 2B. INSERT CABLE INTO SOLDER FERRULE UNTIL BRAIDS SEAT IN C'BORE. THEN SOLDER BRAIDS TO FERRULE WHERE SHOWN.
- 2C. TRIM CABLE DIELECTRIC FLUSH WITH FERRULE FACE.

IN-PROCESS 2

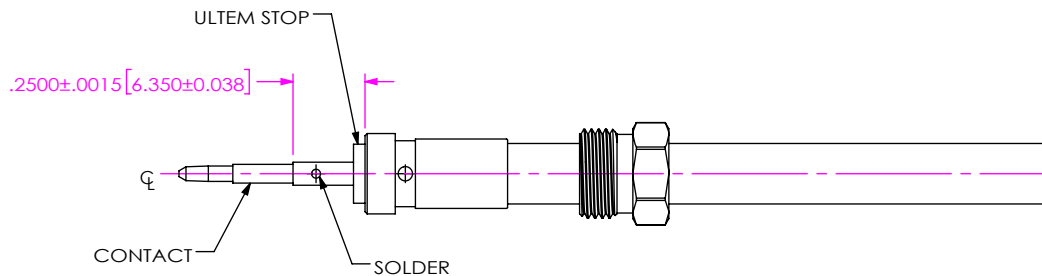

- 3A. SLIDE ULTEM DIELECTRIC STOP OVER CABLE CENTER CONDUCTOR AGAINST SOLDER FERRULE AS SHOWN.
- 3B. SOLDER CONTACT FLUSH AGAINST STOP TO DIMENSION SHOWN.

IN-PROCESS 3

<p>PROPRIETARY NOTE</p> <p>THIS DOCUMENT CONTAINS CONFIDENTIAL AND PROPRIETARY INFORMATION AND ALL DESIGN, MANUFACTURING, REPRODUCTION, USE, PATENT RIGHTS AND SALES RIGHTS ARE EXPRESSLY RESERVED BY SAMTEC, INC. THIS DOCUMENT SHALL NOT BE DISCLOSED, IN WHOLE OR PART, TO ANY UNAUTHORIZED PERSON OR ENTITY NOR REPRODUCED, TRANSFERRED OR INCORPORATED IN ANY OTHER PROJECT IN ANY MANNER WITHOUT THE EXPRESS WRITTEN CONSENT OF SAMTEC, INC.</p>	 <p>520 PARK EAST BLVD, NEW ALBANY, IN 47150 PHONE: 812-944-6733 FAX: 812-948-5047 e-Mail info@SAMTEC.com code 55322</p>
<p>DO NOT SCALE DRAWING</p> <p>SHEET SCALE: 1.5:1</p>	<p>DESCRIPTION: TNCA PLUG, SOLDER CLAMP FOR MICRO-COAX UFA210A CABLE</p> <p>DWG. NO. PRF04-P-C-EP-210A-SS</p> <p>BY: EVE L 11/20/2020 SHEET 2 OF 3</p>

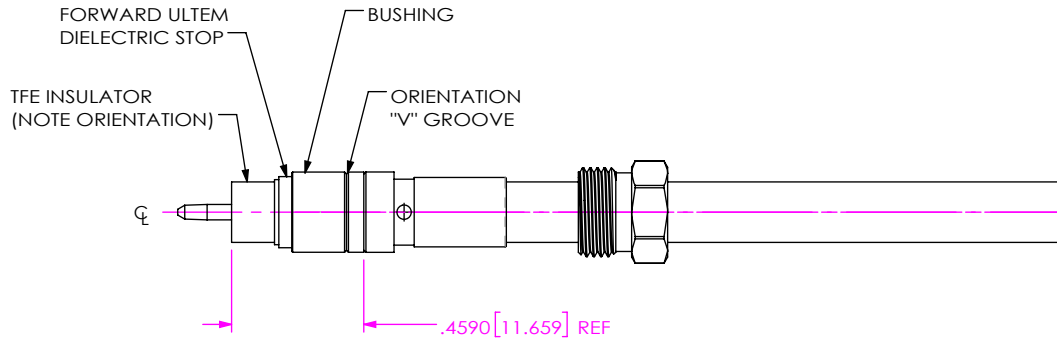

4A. SLIDE BUSHING, FORWARD ULTEM STOP & FORWARD TEFLON INSULATOR OVER CONTACT AS SHOWN.
 (NOTE: ORIENT BUSHING WITH 'V'-GROOVE TOWARD SOLDER FERRULE. ORIENT FORWARD TFE INSULATOR WITH SHOULDER AGAINST FORWARD ULTEM STOP)

IN-PROCESS 4

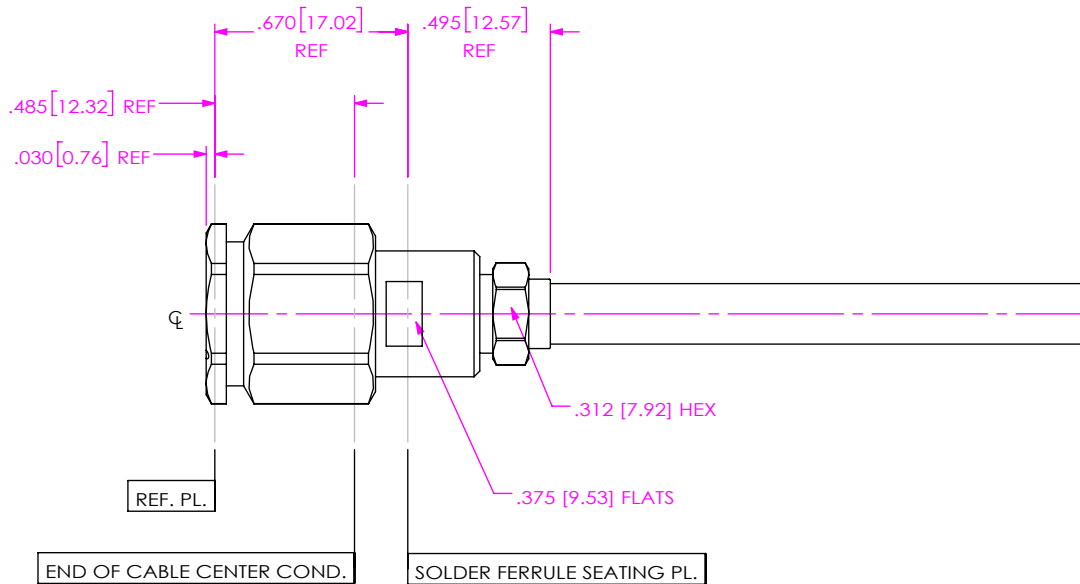

5A. INSERT CABLE/CONTACT SUB-ASSEMBLY INTO CONNECTOR UNTIL SEATED AND TIGHTEN CLAMP NUT TO 35-45 IN-LBS.

IN-PROCESS 5

<p>DO NOT SCALE DRAWING</p> <p>SHEET SCALE: 1.5:1</p>	<p>PROPRIETARY NOTE</p> <p>THIS DOCUMENT CONTAINS CONFIDENTIAL AND PROPRIETARY INFORMATION AND ALL DESIGN, MANUFACTURING, REPRODUCTION, USE, PATENT RIGHTS AND SALES RIGHTS ARE EXPRESSLY RESERVED BY SAMTEC, INC. THIS DOCUMENT SHALL NOT BE DISCLOSED, IN WHOLE OR PART, TO ANY UNAUTHORIZED PERSON OR ENTITY NOR REPRODUCED, TRANSFERRED OR INCORPORATED IN ANY OTHER PROJECT IN ANY MANNER WITHOUT THE EXPRESS WRITTEN CONSENT OF SAMTEC, INC.</p>	
	<p>samtec</p> <p>520 PARK EAST BLVD, NEW ALBANY, IN 47150 PHONE: 812-944-6733 FAX: 812-948-5047 e-Mail: info@SAMTEC.com code 55322</p>	
	<p>DESCRIPTION: TNCA PLUG, SOLDER CLAMP FOR MICRO-COAX UFA210A CABLE</p>	<p>DWG. NO. PRF04-P-C-EP-210A-SS</p>
<p>BY: EVE L</p>	<p>11/20/2020</p>	<p>SHEET 3 OF 3</p>