

REVISIONS				
REV.	DATE	DESCRIPTION	BY	CHK
A	11DEC2020	NEW DRAWING	MK	FE
A1	18FEB2021	UPDATED VIEWS	MK	FE
A2	21JUN2021	ADJUSTMENT OF HOUSING TOLERANCES	MK	FE
A3	16NOV2022	ADJUSTED TO PRODUCTION PROCESS	MK	FE

- #### NOTES
- #### Bemerkungen
- TE CONNECTIVITY (TE) LOGO  
TE Connectivity (TE) Logo
  - ASSY PN, ASSY REVISION, PRODUCTION DATE (CALENDER DAY/YEAR):  
MARKING OPTIONAL AS LASER ENGRAVING OR LASER WITH COLOR CHANGE.  
GOOD PART MARKING AFTER PASSED EOL-Test.  
Assy PN, Assy Revision, Produktionsdatum (Kalendertag/Jahr):  
Beschriftung wahlweise als Lasergravur oder Laser mit Farbschlag.  
Güteilmarkierung nach bestandenen EOL-Test.
  - CONTACT CAVITY NUMBERING  
Kammernummerierung
  - DIFFERENT CODINGS  
Unterschiedliche Kodierungen
  - INTERFACE ACCORDING TO TE-SPECIFICATION 114-18739-1, REV.: D4  
Schnittstelle gemäß TE-Spezifikation 114-18739-1, Rev.: D4
  - SUITABLE TO COUNTERPART: TE PN 1418390  
Passend zu Gegenstück: TE PN 1418390
  - HOLE FOR SELF-TAPPING SCREW EJOT DELTA PT 30  
Bohrung für gewindelfurchende Schraube Ejot Delta PT 30
  - REQUIREMENTS FOR SEALING AREA ON CUSTOMER HOUSING: (0.1) Rz 6.3 µm  
Anforderungen für Dichtungsbereich am Kundengehäuse:
  - POSITION OF SEAL MUST BE CHECKED BEFORE ASSEMBLY  
Vor dem Verbau ist die Dichtung auf richtigen Sitz zu überprüfen
  - MALFUNCTION CAUSED BY LACQUER IS NOT COVERED BY TE WARRANTY.  
Funktionsbeeinträchtigung durch Lackieren liegt nicht im Einfluss und Gewährleistungsumfang von TE.
  - LAYOUT FOR HOUSING CAN BE USED WITH OR WITHOUT POLARISATION FEATURE  
Layout fuer das Gehäuse kann mit oder ohne Polarisierungs-Feature genutzt werden
  - CLEANLESS ACCORDING TO THE TE STANDARD TECHNOLOGY  
Sauberkeit nach der TE Standard Verfahrenstechnik
  - PACKED IN TRAY  
Verpackt im Tray

POS	NO	DESCRIPTION	COLOUR	MATERIAL
1	1	BLACK TAB HEADS (COD. "A") schwarz. Stiftköpfe, Kod. "A"	BLACK schwarz	PBT-GF20 FR
1	1	GRY TAB HEADS (COD. "B") grau. Stiftköpfe, Kod. "B"	GREY grau	PBT-GF20 FR
1	1	GRN TAB HEADS (COD. "C") grün. Stiftköpfe, Kod. "C"	GREEN grün	PBT-GF20 FR
1	1	BLU TAB HEADS (COD. "D") blau. Stiftköpfe, Kod. "D"	BLUE blau	PBT-GF20 FR
2	2	SILVER TAB HEADS (COD. "E") silber. Stiftköpfe, Kod. "E"	SILVER ver Silber	CuSn
3	3	2.8mm TAB HEADS (COD. "F") 2.8mm. Stiftköpfe, Kod. "F"	GRN grün	VMO

DIMENSION AND TOLERANCES ACCORDING TO:  
Bemaßungen und Toleranzen gemäß:  
DIN ISO 20457  
DIN EN ISO 8015 (AD) - DIN EN ISO 291  
DIN EN ISO 14405-1/-2/-3

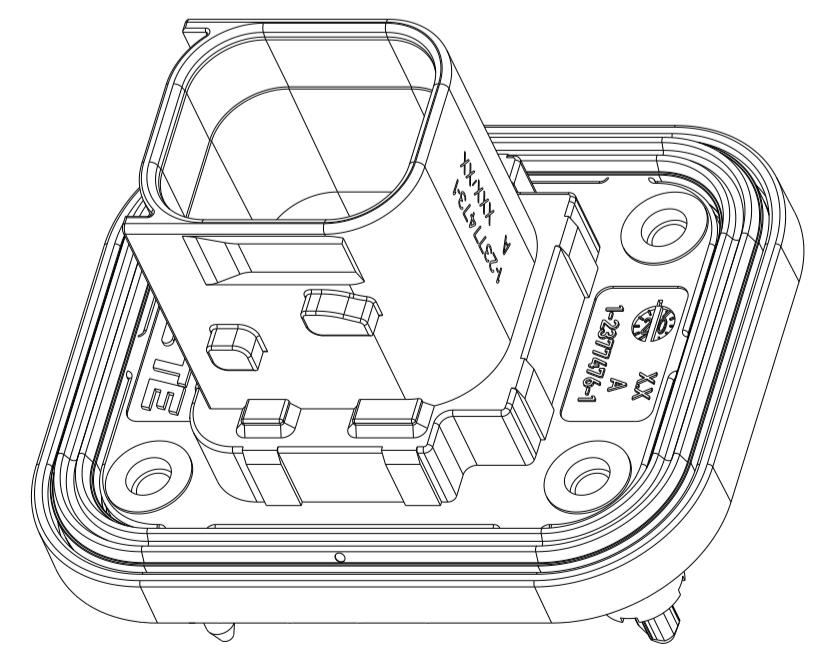

REV.	DATE	DESCRIPTION	BY	CHK
4	25NOV2020	1-2377473-1	M. Kilian	J. Hoffmann
3	09DEC2020	1-2377473-1	M. Kilian	J. Hoffmann
2	11DEC2020	1-2377473-1	M. Kilian	J. Hoffmann
1	11DEC2020	1-2377473-1	M. Kilian	J. Hoffmann

TE ORDER-NO.	REV.	NO. OF POS.	CODE	QUANTITY	ITEM
TE Bestell-Nr.		Polzahl	Kodierung	Stueck	NO ASSY
4-2377473-1	-	4	A	1	4
3-2377473-1	-	4	B	1	3
2-2377473-1	A	4	B	1	2
1-2377473-1	A	4	A	1	1

MATERIAL	DESCRIPTION	WEIGHT	SCALE
SEE TABLE	SEE TABLE	17.9 g	2:1

APVD	DATE	DESCRIPTION	BY	CHK
M. Kilian	25NOV2020	1-2377473-1	M. Kilian	J. Hoffmann
J. Hoffmann	09DEC2020	1-2377473-1	M. Kilian	J. Hoffmann
M. Kilian	11DEC2020	1-2377473-1	M. Kilian	J. Hoffmann
M. Kilian	11DEC2020	1-2377473-1	M. Kilian	J. Hoffmann

NAME	SIZE	CAGE CODE	DRAWING NO.	RESTRICTED TO
4POS .TAB 2.8X0.8. HDR ASSY. 180DEG 4pol. Tab 2.8x0.8. Stiftwanne. 180 Grad Heavy Duty Sealed Connector Series	A1	07779	2-2377473	NUR FÜR

CUSTOMER DRAWING	SCALE	SHEET	OF	REV.
KUNDENZEICHNUNG	2:1	1	1	A3