

SECTION A-A

NOTES:

1. MATERIALS:

HOUSING: GLASS-FILLED NYLON 46, UL RATED 94V-0, COLOR BEIGE.

PINS: BRASS ALLOY, C26000

2. PLATING: 2.54µM MIN. TIN/LEAD or TIN OVER 1.27µM MIN. NICKEL.

3. DRAWING SHOWS PLUG WITH 5 CIRCUITS.

4. HEADER TO BE USED WITH CRIMP HOUSING, P/N 87439 AND CRIMP TERMINAL, P/N 87421.

UPDATE REVISION EC NO: S2005-0714 2005/10/19 DRWN:KSEE 2005/10/19 CHKD:BLW 2005/11/05 APPR:PTL:IM	QUALITY SYMBOLS ▽=0 ▽=0	GENERAL TOLERANCES (UNLESS SPECIFIED)		DIMENSION STYLE	SCALE	DESIGN UNITS	THIRD ANGLE PROJECTION	
				MM ONLY	NTS	METRIC		
				mm	INCH	TITLE		
		4 PLACES	± ---	± ---	DRAWN BY KCLING			DATE 1994/04/08
3 PLACES	± ---	± ---	CHECKED BY			DATE 1994/04/21		
2 PLACES	± 0.20	± ---	APPROVED BY			DATE 1994/04/21	MOLEX INCORPORATED MOLEX	
1 PLACE	± ---	± ---	MATERIAL NO.			DOCUMENT NO. SD-87437-**31		
DRAFT WHERE APPLICABLE MUST REMAIN WITHIN DIMENSIONS		ANGULAR ± 3°		SEE TABLE		SHEET NO. 1 OF 3		

10 9 8 7 6 5 4 3 2 1

F

E

D

C

B

A

LEAD FREE TERMINAL P/N	HEADER IN TUBE PACKING	HEADER IN TAPE & REEL	TIN/LEAD TERMINAL P/N	HEADER IN TUBE PACKING	HEADER IN TAPE & REEL	CIRCUIT SIZE	A	B	C	D	E
87437-8083	87437-0242	87437-0243	87437-8082	87437-0232	87437-0233	2	1.50	3.30	3.70	4.30	1.70
	87437-0342	87437-0343		87437-0332	87437-0333	3	3.00	4.80	5.20	5.80	3.20
	87437-0442	87437-0443		87437-0432	87437-0433	4	4.50	6.30	6.70	7.30	4.70
	87437-0542	87437-0543		87437-0532	87437-0533	5	6.00	7.80	8.20	8.80	6.20
	87437-0642	87437-0643		87437-0632	87437-0633	6	7.50	9.30	9.70	10.30	7.70
	87437-0742	87437-0743		87437-0732	87437-0733	7	9.00	10.80	11.20	11.80	9.20
	87437-0842	87437-0843		87437-0832	87437-0833	8	10.50	12.30	12.70	13.30	10.70
	87437-0942	87437-0943		87437-0932	87437-0933	9	12.00	13.80	14.20	14.80	12.20
	87437-1042	87437-1043		87437-1032	87437-1033	10	13.50	15.30	15.70	16.30	13.70
	87437-1142	87437-1143		87437-1132	87437-1133	11	15.00	16.80	17.20	17.80	15.20
	87437-1242	87437-1243		87437-1232	87437-1233	12	16.50	18.30	18.70	19.30	16.70
	87437-1342	87437-1343		87437-1332	87437-1333	13	18.00	19.80	20.20	20.80	18.20
	87437-1442	87437-1443		87437-1432	87437-1433	14	19.50	21.30	21.70	22.30	19.70
	87437-1542	87437-1543		87437-1532	87437-1533	15	21.00	22.80	23.20	23.80	21.20
	LEAD FREE			TIN/LEAD							

UPDATE REVISION EC NO: S2005-0714 DRWN:KSEE CHKD:BLW APPR:PTLIM	2005/10/19 2005/10/19 2005/11/05	QUALITY SYMBOLS ▽=0 ▽=0	GENERAL TOLERANCES (UNLESS SPECIFIED)		DIMENSION STYLE MM ONLY		SCALE NTS	DESIGN UNITS METRIC	THIRD ANGLE PROJECTION				
				mm	INCH	DRAWN BY KCLING	DATE 1994/04/08	TITLE SALES DRAWING 1.50MM PITCH, W-T-B VERTICAL HEADER, SMT					
			4 PLACES	± ---	± ---	CHECKED BY SKTOH	DATE 1994/04/21						
			3 PLACES	± ---	± ---	APPROVED BY ROYWONG		DATE 1994/04/21	MOLEX INCORPORATED DOCUMENT NO. SD-87437-**31				
			2 PLACES	± 0.20	± ---	MATERIAL NO.		DATE					
1 PLACE	± ---	± ---	DRAFT WHERE APPLICABLE MUST REMAIN WITHIN DIMENSIONS		DATE	SHEET NO. 2 OF 3							

9 8 7 6 5 4 3 2 1

15	44	20.20±0.15	100	44.40	50.40	2.00±0.15
11, 12, 13, 14	32	14.20±0.10	100	32.40	38.40	2.00±0.10
7, 8, 9, 10	24	11.50±0.10	100	24.40	30.40	2.00±0.10
2, 3, 4, 5, 6	16	7.50±0.10	100	16.40	22.40	2.00±0.10
CIRCUIT SIZE	A	B	N	G	T MAX	P

EMBOSSED CARRIER TAPE PACKING DETAILS

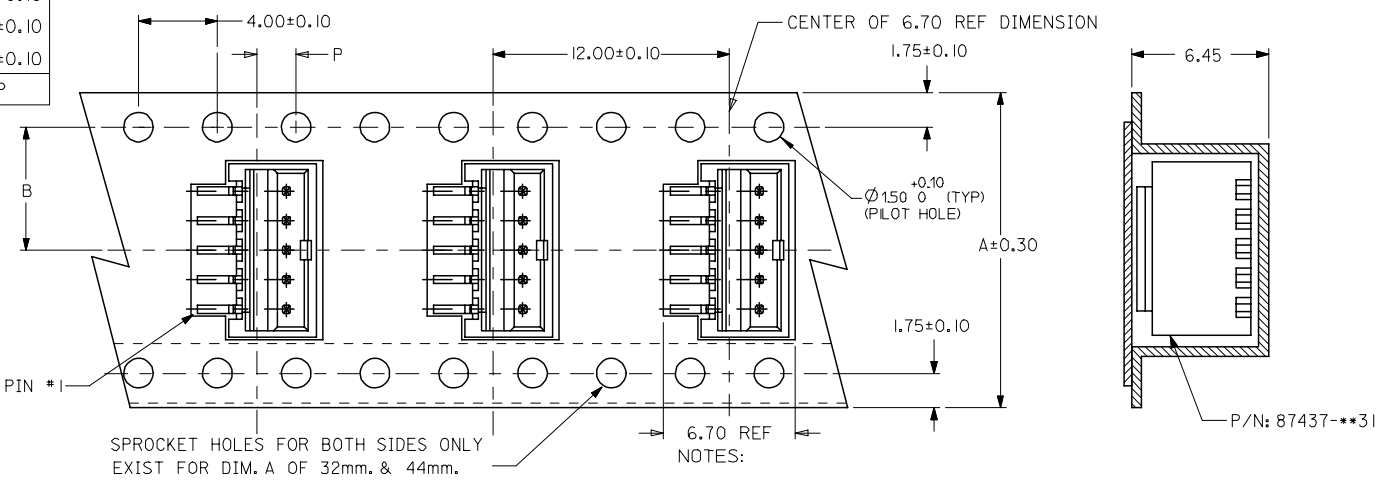

REEL DETAILS

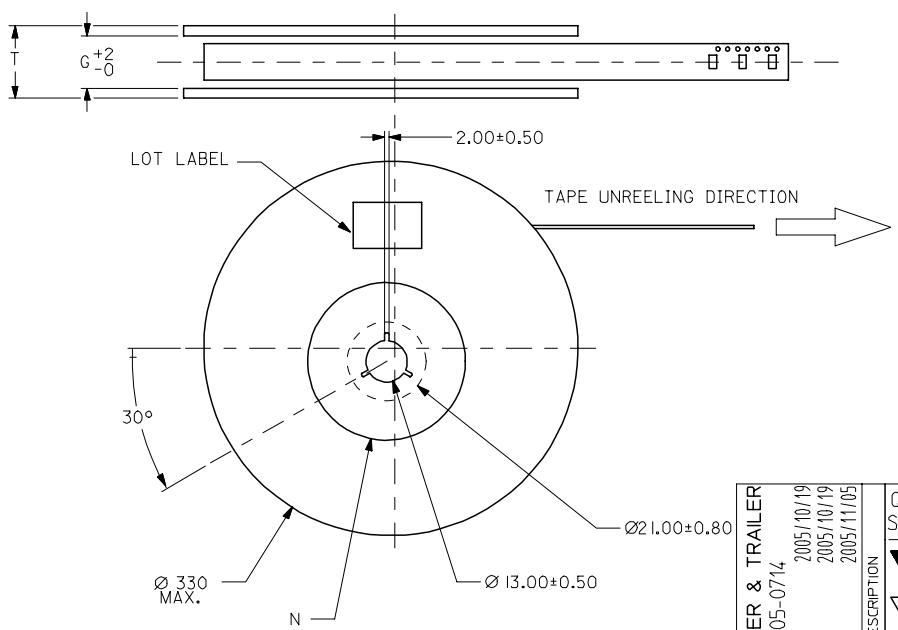

TAPE UNREELING DIRECTION

- LEADER AND TRAILER TAPE
- PEELING OFF FORCE OF THE TOP TAPE: 20-80gf.
 (PEELING DIRECTION AS SHOWN IN FOLLOWING FIGURE)
- PACKAGING STANDARD IS AS PER EIA-481.
- TAPE & REEL QUANTITY = 1000 PCS/REEL
- THE TAPE IS TREATED FOR ANTI-STATIC

ADD LEADER & TRAILER	DESCRIPTION	QUALITY SYMBOLS
EC NO: S2005-0714	2005/10/19	▽=0
DRWN:KSEE	2005/10/19	▽=0
CHKD:BLW	2005/11/05	
APPR:PTLIM		
REV		

GENERAL TOLERANCES (UNLESS SPECIFIED)	DIMENSION STYLE	SCALE	DESIGN UNITS	THIRD ANGLE PROJECTION
	MM ONLY	NTS	METRIC	
4 PLACES ± --- ± ---	DRAWN BY	DATE	TITLE	
3 PLACES ± --- ± ---	KCLING	1994/04/08	SALES DRAWING	
2 PLACES ± 0.20 ± ---	CHECKED BY	DATE	1.50MM PITCH, W-T-B	
1 PLACE ± --- ± ---	SKTOH	1994/04/21	VERTICAL HEADER, SMT	
ANGULAR ± 3 °	APPROVED BY	DATE	MOLEX INCORPORATED	
	ROYWONG	1994/04/24		
DRAFT WHERE APPLICABLE MUST REMAIN WITHIN DIMENSIONS	MATERIAL NO.	DOCUMENT NO.	SHEET NO.	
	SEE TABLE	SD-87437-***31	3 OF 3	
	SIZE A3	THIS DRAWING CONTAINS INFORMATION THAT IS PROPRIETARY TO MOLEX INCORPORATED AND SHOULD NOT BE USED WITHOUT WRITTEN PERMISSION		