

| | | |
|-------------|--------------|--------|
| ORDER NO. | WOODHEAD NO. | COLOR |
| 130147-0299 | 29W49-P | YELLOW |

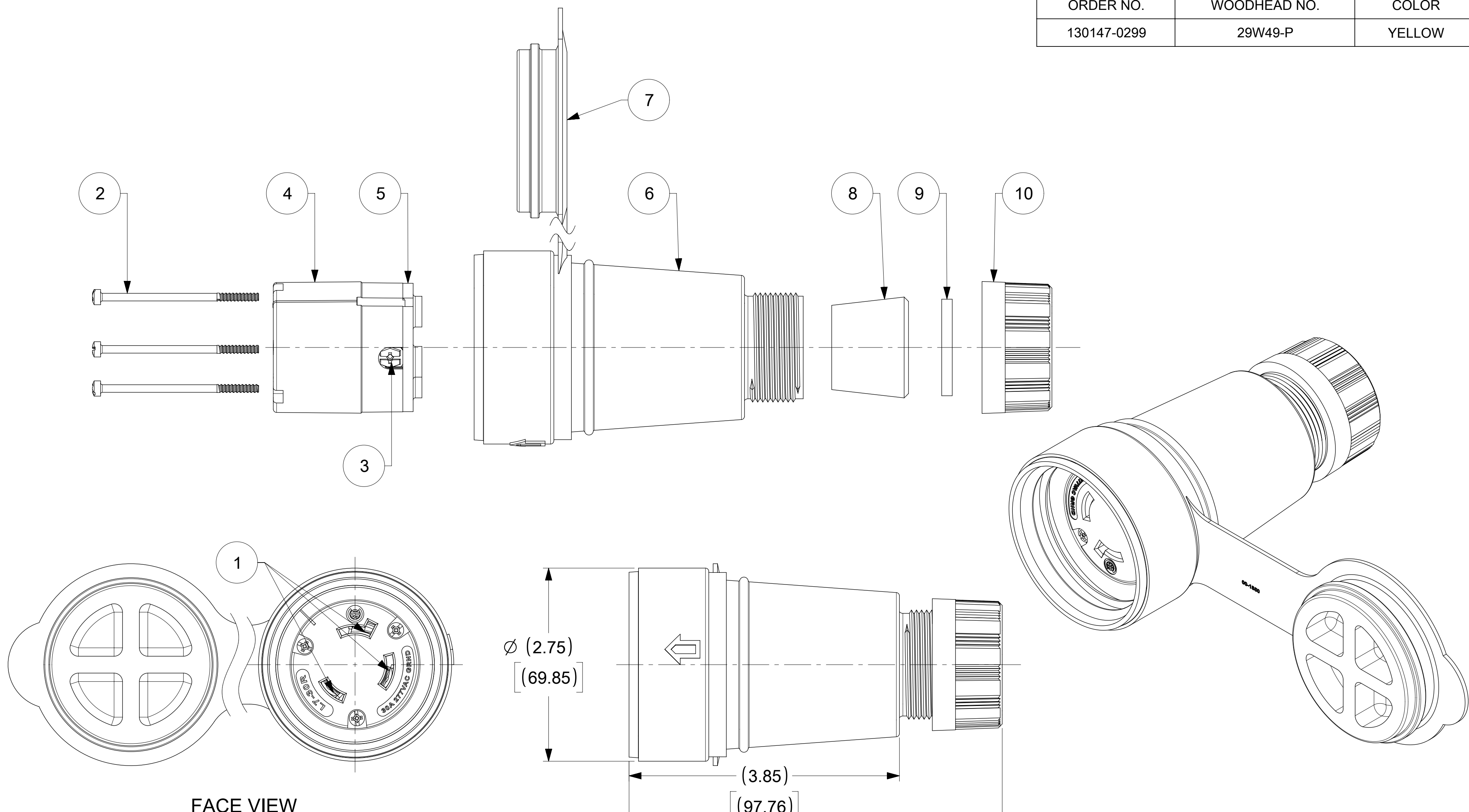

FACE VIEW

| ITEM NO. | DESCRIPTIONS | MATERIAL | QTY. |
|----------|-------------------------------|---------------------------|------|
| 1 | BLADE | BRASS, NICKEL PLATED | 3 |
| 2 | RETAINING SCREWS | STAINLESS STEEL | 3 |
| 3 | CLAMP AND TERMINAL SCREW ASSY | BRASS, ZINC PLATED | 3 |
| 4 | INSERT | NYLON | 1 |
| 5 | TERMINAL COVER | POLYCARBONATE | 1 |
| 6 | HOUSING | SILICON WITH NYLON THREAD | 1 |
| 7 | COVER CLOSURE | SILICON WITH NYLON THREAD | 1 |
| 8 | GROMMET | RUBBER | 4 |
| 9 | FRICTION RING | NYLON | 1 |
| 10 | COMPRESSION NUT | NYLON | 1 |

| | | | |
|------------------|--|---|----------------------------|
| SYMBOLS | | THIS DRAWING CONTAINS INFORMATION THAT IS PROPRIETARY TO MOLEX ELECTRONIC TECHNOLOGIES, LLC AND SHOULD NOT BE USED WITHOUT WRITTEN PERMISSION | |
| ▽ = 0 | INCH[MM] | SCALE | CURRENT REV DESC: RELEASED |
| ▽ = 0 | NTS | | |
| ▽ = 0 | GENERAL TOLERANCES (UNLESS SPECIFIED) | | |
| ▽ = 0 | | MM | INCH |
| ▽ = 0 | 4 PLACES | ± | ± |
| ▽ = 0 | 3 PLACES | ± | ± |
| ▽ = 0 | 2 PLACES | ± | ± |
| ▽ = 0 | 1 PLACE | ± | ± |
| ▽ = 0 | 0 PLACES | ± | ± |
| ▽ = 0 | ANGULAR TOL | ± | ° |
| ▽ = 0 | DRAFT WHERE APPLICABLE MUST REMAIN WITHIN DIMENSIONS | | THIRD ANGLE PROJECTION |
| ▽ = 0 | | DRAWING | SERIES |
| | | C-SIZE | 130147 |
| EC NO: 614386 | | 2018/12/28 | |
| DRWN: DSOPPIN | | 2019/04/17 | |
| CHK'D: DNGUYEN62 | | 2019/04/25 | |
| APPR: HKNEELAND | | INITIAL REVISION: | |
| | | DRWN: DSOPPIN | |
| | | 2018/12/28 | |
| | | APPR: HKNEELAND | |
| | | 2019/04/25 | |
| DOCUMENT NUMBER | | DOC TYPE | DOC PART |
| 1301470299 | | PSD | 000 |
| MATERIAL NUMBER | | CUSTOMER | SHEET NUMBER |
| SEE TABLE | | GENERAL MARKET | 1 OF 1 |