

ELECTRICAL	MECHANICAL	ENVIRONMENTAL
IMPEDANCE <u>50 Ohm</u> FREQUENCY RANGE <u>DC to 6GHz</u> INSERTION LOSS: <u>Max. 0.05*SQRT(F) dB</u> VSWR: <u>Max. 1.15@0-3GHz</u> <u>Max. 1.20@3-6GHz</u> DIELECTRIC WITHSTAND VOLTAGE: <u>Max. 2500 V RMS</u> INSULATION RESISTANCE <u>Min. 5000 Mohms</u> PIM3: <u>Max. -160dBc @2x20W, 900MHz, 1800MHz,</u> <u>2100MHz tested with cable</u>	MATING CYCLES: <u>MIN. 100 CYCLES</u> RECOMMENDED TORQUE: <u>5Nm</u> CABLE PULLING: <u>500N MIN.</u> CABLE TORSION: <u>5Nm MIN.</u>	TEMPERATURE RANGE: <u>-40°~+85°C</u> SALT SPRAY: <u>96H</u> INTERFACE SEAL: <u>IP68(1m, 24h) MATED</u> CLAMP SEAL: <u>IP67(1m, 0.5h)</u>

P	LTR	DESCRIPTION	DATE	DWN	APVD

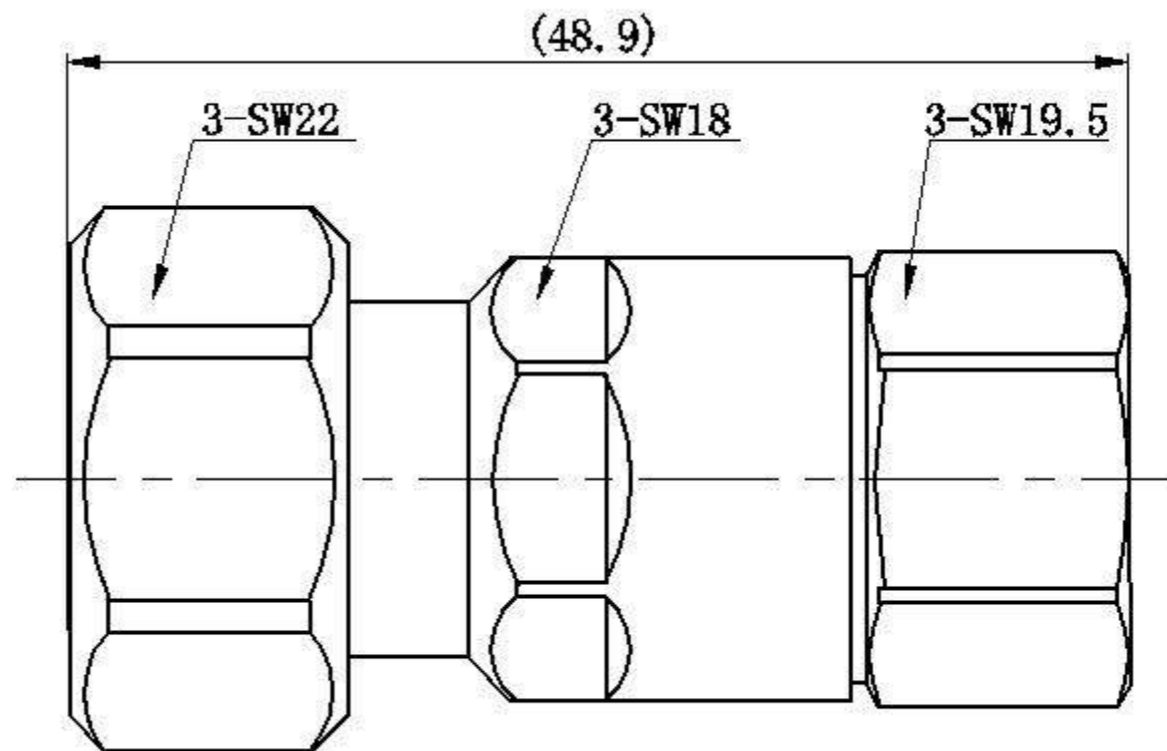

RECOMMENDED CABLE DIMENSION

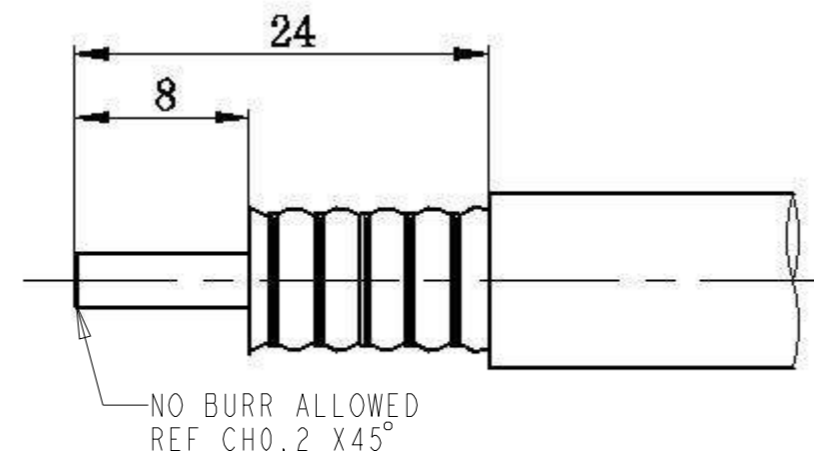

NOTE:

1. INTERFACE ACCORDING TO IEC 61169-54

P/N	PART NAME	MATERIAL	PLATING
2081971-1	CENTER CONTACT	BRONZE	SILVER
	OUTER CONTACT	BRASS/BRONZE	WHITE BRONZE
	INSULATOR	PTFE	
	O-RING	SILICONE RUBBER	
	OTHERS	BRASS	NICKEL

THIS DRAWING IS A CONTROLLED DOCUMENT.		DWN	JZ	10MAR2020					
DIMENSIONS: mm		CHK	RZ	10MAR2020					
TOLERANCES UNLESS OTHERWISE SPECIFIED:		APVD	RS	10MAR2020	NAME				
0 PLC ±0.3 1 PLC ±0.2 2 PLC ±0.20 3 PLC ±0.200 4 PLC ±0.2000 ANGLES ±		PRODUCT SPEC		108-115175		4.3-10 STRAIGHT PLUG, SCREW FOR 1/2 CABLE CLAMP TYPE			
MATERIAL SEE TABLE		APPLICATION SPEC		408-160015		SIZE	CAGE CODE	DRAWING NO	RESTRICTED TO
FINISH SEE TABLE		WEIGHT		61.5g		A3	00779	©-2081971	-
-		CUSTOMER DRAWING			SCALE	1:1	SHEET	1 OF 2	REV
-									A

REVISIONS

P	LTR	DESCRIPTION	DATE	DWN	APVD

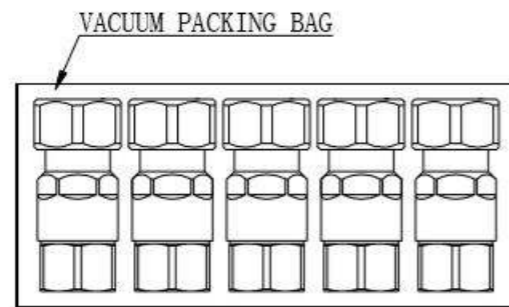

VACUUM PACKING(5PCS/BAG)

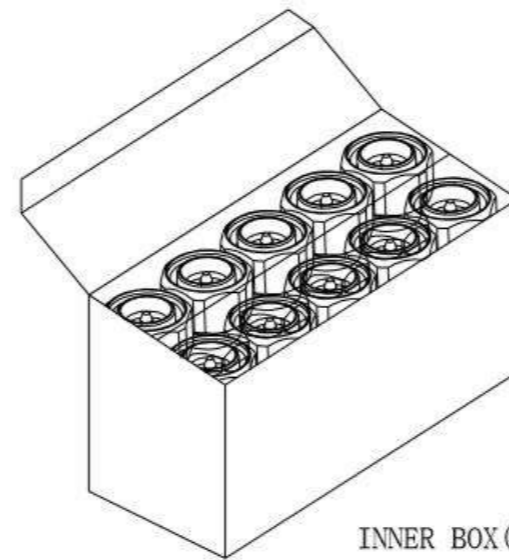

INNER BOX (10PCS/BOX)

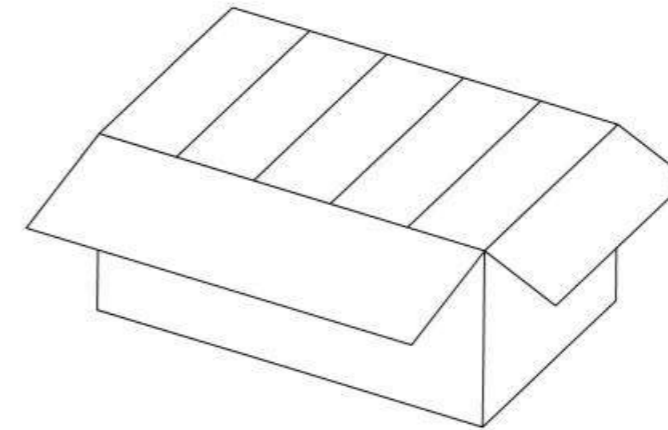

OUTER BOX (150PCS/BOX)

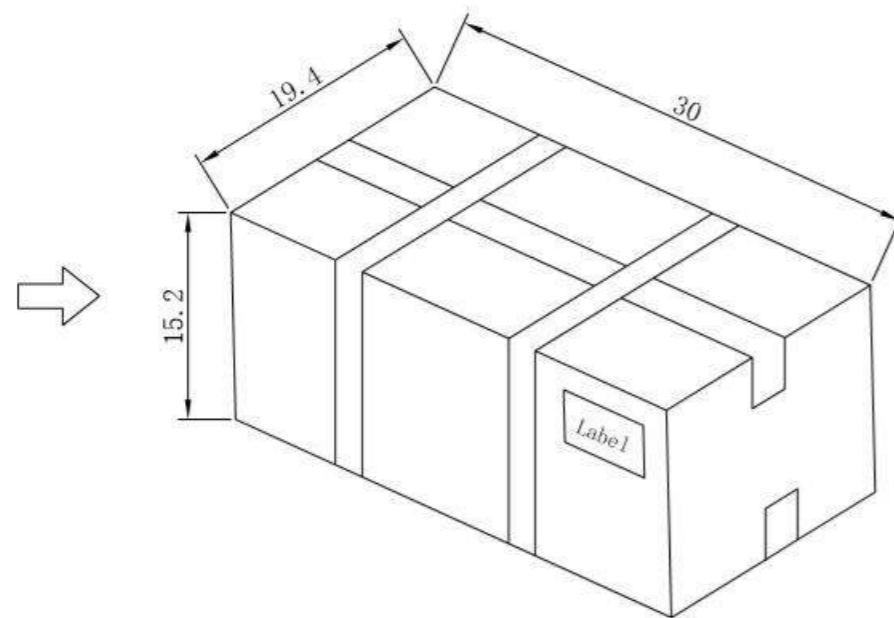

PACKAGE

(BOX SIZE ONLY FOR REFERENCE, UNIT: CM)

THIS DRAWING IS A CONTROLLED DOCUMENT.		DWN JZ	10MAR2020		
DIMENSIONS: mm		CHK RZ	10MAR2020		
		APVD RS	10MAR2020		
TOLERANCES UNLESS OTHERWISE SPECIFIED:		PRODUCT SPEC		NAME	
0 PLC ±0.3	1 PLC ±0.2	108-115175		4.3-10 STRAIGHT PLUG, SCREW	
2 PLC ±0.20	3 PLC ±0.200	APPLICATION SPEC		FOR 1/2 CABLE	
4 PLC ±0.2000	ANGLES ±	408-160015		CLAMP TYPE	
MATERIAL SEE TABLE	FINISH SEE TABLE	WEIGHT	61.5g	SIZE A3	CAGE CODE 00779
-	-	CUSTOMER DRAWING		DRAWING NO C-2081971	RESTRICTED TO -
				SCALE 1:1	SHEET 2 OF 2
				REV A	