

PART NUMBER	REV	FIRST USED	POWER UNIT	FEED TYPE	DESCRIPTION
1852378-1	B	122500-1	LEADMAKER	AIR FEED	CUTS CARRIER
1852378-2	B	565435-5	BENCH MODEL K	AIR FEED	CUTS CARRIER
1852378-3	B	354500-1	BENCH MODEL G	AIR FEED	CUTS CARRIER
7-1852378-7	A	-	-	-	SPARE PARTS

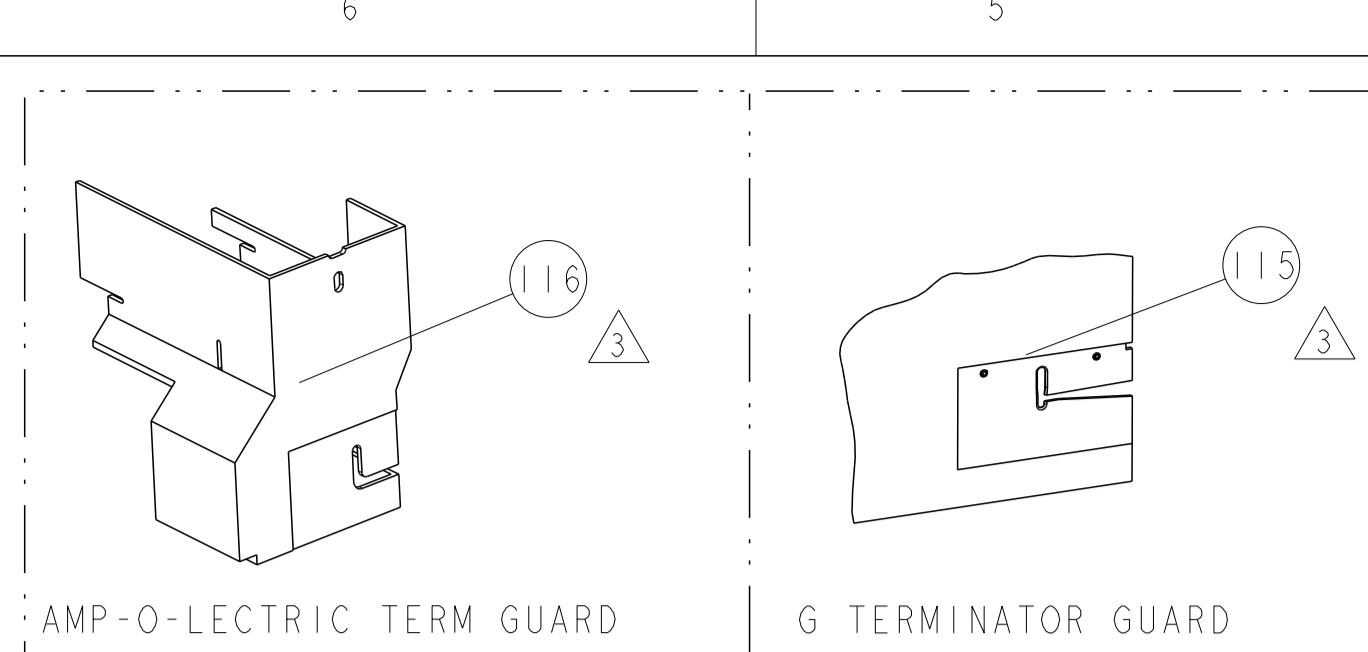

TERMINAL NAME: MEDIUM RING TERMINAL			
TE PN	MANUF PN	PACKARD TERM - PACKARD CRIMP SPECS	
1949212-1	12103504		
1949212-2	12103503	PAD LTR	CRIMP HEIGHT
-	-	A	3.35±0.05mm [1.32±.002]
-	-	B	3.20±0.05mm [1.26±.002]
-	-	C	-
-	-	D	-
-	-	CRIMP	SIZE
-	-	WIRE	5.46mm [1.215]
-	-	INSUL	6.48mm [1.255]
-	-	FEED	19.86mm
WIRE STRIP LENGTH	TERM APPL SPEC	APPLICATOR INSTRUCTIONS	SET UP GAGE
8.1mm	NONE	408-8040	458637-1

LOC	DIST	REVISIONS			
A	66	REV	DESCRIPTION	DATE	BY
		A	RELEASED	30APR2007	BH
		B	ECR-07-016562	13JUL2007	MY
		B1	ECR-14-005184	08APR2014	XZ

- ▲ RECOMMENDED SPARE PARTS
- ▲ GREASE LIGHTLY
- ▲ GUARD MUST BE IN PLACE WHEN OPERATING APPLICATOR IN A BENCH MACHINE
- ▲ INSTALL ITEMS 101, 102 & 119 ON SIDE OF STRIPPER ON APPL HOUSING USING ITEM 21.

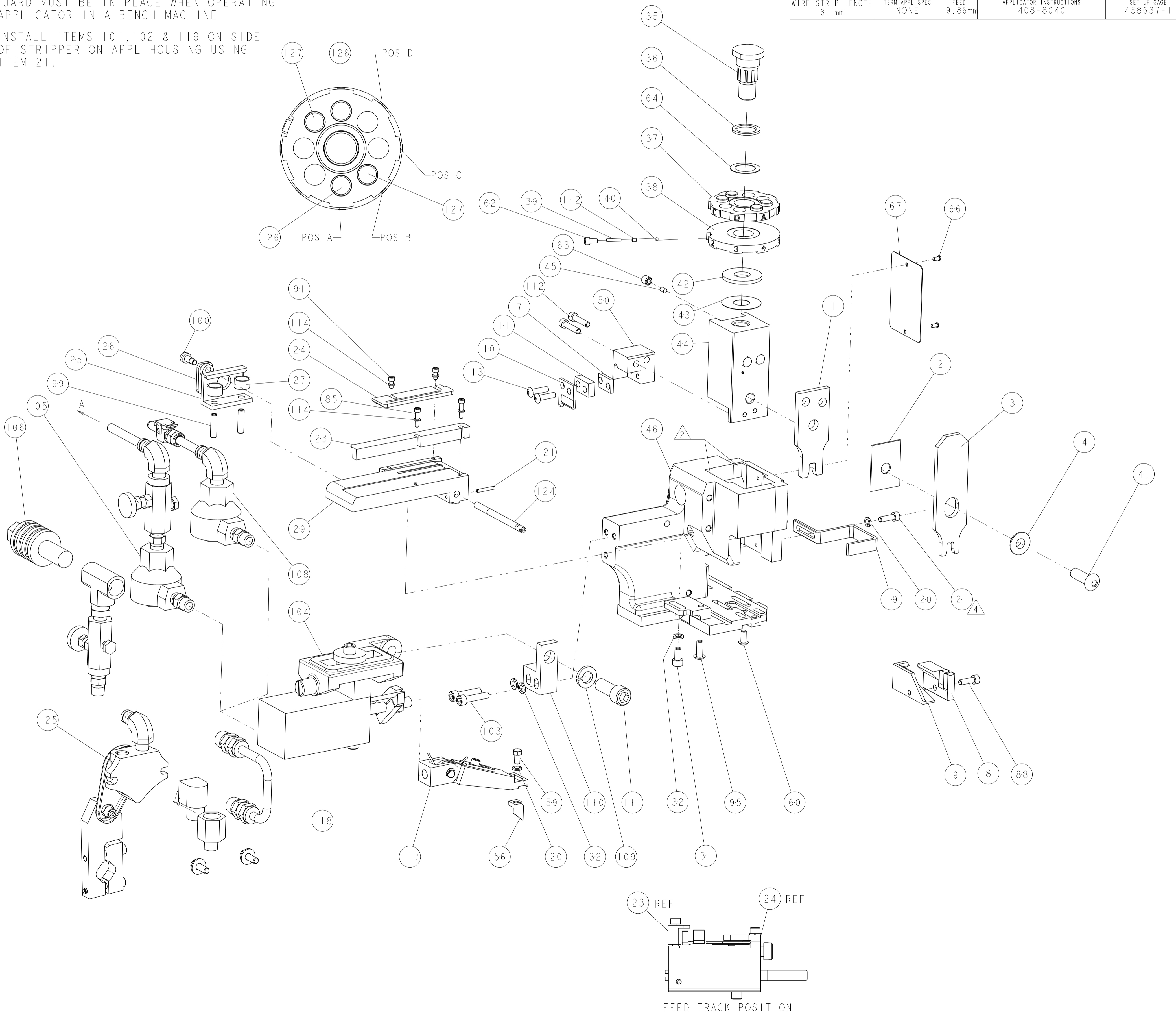

-	2	2	2	-	5-354779-6	PIN, WIRE DISC, .3270	127
-	2	2	2	-	4-354779-8	PIN, WIRE DISC, .3230	126
-	-	1	1	-	455350-4	AIR BLAST ASS'Y	125
-	1	1	1	-	690432-3	ADJUSTMENT SCREW	124
-	1	1	1	-	3-21028-8	PIN, SLOTTED SPRING .094 X .625	121
-	18	24	18	IN	27319-4	TUBING, POLY-FLO, NATURAL	119
-	-	1	1	-	692655-6	AIR FEED VALVE ASSEMBLY	118
-	1	1	1	-	461062-1	FEED FINGER ASSEMBLY	117
-	-	REF	-	..	455749-1	GUARD WINDOW	116
-	REF	-	-	..	679532-1	INSERT, GUARD	115
-	4	4	4	-	21024-2	WASHER, SPRG LOCK, REG NO 4	114
-	2	2	2	-	2-21002-3	SCR, BTN SKT HD CAP 8-32 X .625	113
-	1	1	1	-	690603-1	SPRING ASSIST AMP-O-MATOR APPLICATOR	112
-	2	2	2	-	2-21000-9	SCR, SKT HD CAP 8-32 X .750	112
-	1	1	1	-	3-21001-5	SCR, SKT HD CAP 3/8-16 X 1.000	111
-	1	1	1	-	459610-1	MOUNT, FEED BRACKET	110
-	1	1	1	-	21024-8	WASHER, SPRG LOCK, REG 3/8	109
-	1	-	1	-	692655-7	AIR FEED VALVE ASSEMBLY	108
-	-	1	-	-	24042-2	VALVE, SLEEVE, 3-WAY	106
-	-	1	-	-	692655-5	AIR FEED VALVE ASSEMBLY	105
-	1	1	1	-	461065-1	ASSEMBLY, AIR FEED	104
-	2	2	2	-	3-21000-8	SCR, SKT HD CAP 10-32 X .875	103
-	1	1	1	-	986220-3	CLAMP, CABLE, BLACK	102
-	1	-	1	..	23238-1	INSERT, COUPLING	101
-	1	1	1	-	22353-8	SCR, SHLD, SLOT HD, 3/16 DIA	100
-	2	2	2	-	5-21006-6	SCR, SET, CUP POINT 10-32 X .750	99
-	1	1	1	-	2-21002-7	SCR, BTN SKT HD CAP 10-32 X .500	95
-	2	2	2	-	1-21000-3	SCR, SKT HD CAP 4-40 X .250	91
-	1	1	1	-	2-21000-7	SCR, SKT HD CAP 8-32 X .500	88
-	2	2	2	-	1-21000-5	SCR, SKT HD CAP 4-40 X .500	85
-	1	1	1	-	4088040	SF APPL INST 408-8040	72
-	1	1	1	-	217238-1	GENERAL INSTRUCTION PKG	71
-	1	1	1	-	461264-1	PLATE, IDENTIFICATION	67
-	2	2	2	-	21017-2	SCREW, DRIVE	66
-	1	1	1	-	986950-1	WASHER, FLAT PRECISION	64
-	1	1	1	-	21009-2	SCR, SET, SELF LOCKING 1/4-20 X .250	63
-	1	1	1	-	23030-1	SCR, SKT HD CAP 6-32 X .25	62
-	1	1	1	-	22733-8	SCR, BHSC, SELF-LOCKING, 8-32 X .375	60
-	1	1	1	-	2-22603-0	SCR, HEX HD CAP 8-32 X .312	59
-	1	1	1	-	2-694433-8	FEED PAWL	56
-	1	1	1	-	1633513-2	HOLDER, SLUG BLADE	50
-	1	1	1	-	1633399-1	APPL., BASIC AIR FEED SUB ASSY	46
-	1	1	1	-	690191-1	PLUG, NYLON	45
-	1	1	1	-	455673-6	RAM, SIDE FEED	44
-	1	1	1	-	690125-1	SHIM SUB-ASSY	43
-	1	1	1	-	1-690124-0	WASHER, RAM (.100)	42
-	1	1	1	-	7-21002-9	SCR, BTN SKT HD CAP 5/16-24 X 1.00	41
-	1	1	1	-	23241-6	BALL, STEEL	40
-	1	1	1	-	690170-1	SPRING, COMPRESSION	39
-	1	1	1	-	690142-4	DISC, INSULATION	38
-	1	1	1	-	354777-1	WIRE DISC, ASSEMBLY	37
-	1	1	1	-	22480-5	SPRING, COMPRESSION	36
-	1	1	1	-	690212-1	POST, RAM	35
-	3	3	3	-	21024-5	WASHER, SPRG LOCK, REG NO 10	32
-	1	1	1	-	3-21000-4	SCR, SKT HD CAP 10-32 X .375	31
-	1	1	1	-	3-844048-1	PLATE, REAR STRIP GUIDE	29
-	2	2	2	-	22284-1	SPRING, COMPRESSION	27
-	1	1	1	-	240793-4	LEVER, DRAG RELEASE	26
-	1	1	1	-	240792-1	DRAG, TERMINAL	25
-	1	1	1	-	1633497-3	REAR STRIP GUIDE	24
-	1	1	1	-	1-189124-1	GUIDE, FRONT STRIP	23
-	1	1	1	-	2-21000-7	SCR, SKT HD CAP 8-32 X .500	21
-	2	2	2	-	21024-4	WASHER, SPRG LOCK, REG NO 8	20
-	1	1	1	-	1-458230-8	STRIPPER	19
-	1	1	1	-	8-240641-8	SPACER	11
-	1	1	1	-	1633512-3	BLADE, SLUG	10
-	1	1	1	-	1-1633124-0	PLATE, REAR SHEAR	9
-	1	1	1	-	1633529-1	ANVIL, SPECIAL, COMBINATION	8
-	1	1	1	-	8-240641-6	SPACER	7
-	1	1	1	-	3-238009-3	BLOCK, FL CRIMPER SPACER	4
-	1	1	1	-	3-1633471-5	CRIMPER, INSULATION F	3
-	1	1	1	-	1-455888-0	SPACER, CRIMPER	2
-	1	1	1	-	7-1633305-7	CRIMPER, WIRE PREMIUM	1

DIMENSIONS: INCHES		TOLERANCES UNLESS OTHERWISE SPECIFIED:		DWN B. HIGMAN 02JAN2007		CHK B. HIGMAN 02JAN2007		APVD T. BENCHOFF 02JAN2007		NAME SIDE FEED HDM APPLICATOR	
0 PLC ±.1		1 PLC ±.01		2 PLC ±.001		3 PLC ±.0001		4 PLC ±.0001		SIZE CAGE CODE DRAWING NO	
ANGLES ±.0001		FINISH		WEIGHT		SCALE 3:5		SHEET 1 OF 1		REV B1	
MATERIAL		CUSTOMER DRAWING		PART NO		DESCRIPTION		ITEM NO		RESTRICTED TO	
				A1 00779		C=1852378					

CUSTOMER VIEWABLE ASSEMBLY