

**STRAIGHT PLUG CRIMP TYPE**

**R141A.082.161**

**CABLE 5/50 S**

Series : ECO BNC 50

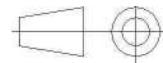
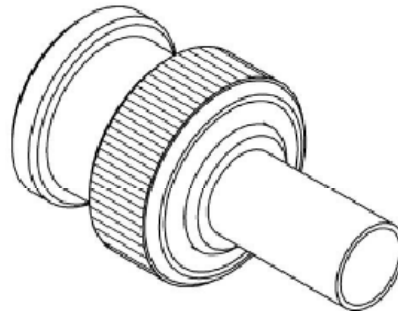
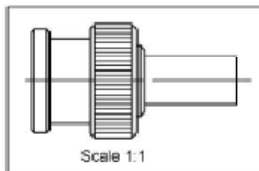
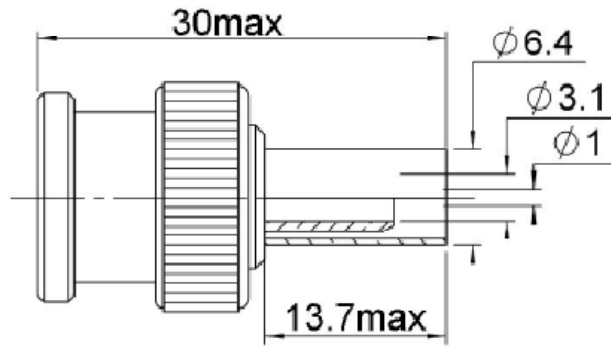

All dimensions are in mm.

COMPONENTS	MATERIALS	PLATING ( $\mu\text{m}$ )
BODY	BRASS	NICKEL
CENTER CONTACT	BRASS	GOLD OVER NICKEL
OUTER CONTACT		
INSULATOR	PTFE	
GASKET		
OTHERS PARTS	BRASS	NICKEL
-	-	-
-	-	-

Issue : 1233 A

In the effort to improve our products, we reserve the right to make changes judged to be necessary.



**STRAIGHT PLUG CRIMP TYPE**

**R141A.082.161**

**CABLE 5/50 S**

Series : ECO BNC 50

**PACKAGING**

Standard	Unit	Other
<b>100</b>	<b>'W' option</b>	<b>Contact us</b>

**SPECIFICATION**

**ELECTRICAL CHARACTERISTICS**

Impedance		<b>50</b> Ω
Frequency		<b>0-1</b> GHz
VSWR	<b>1.3 + 0,0000</b>	x F(GHz) Maxi
Insertion loss		<b>0.2</b> √F(GHz) dB Maxi
RF leakage	- (	<b>NA</b> - F(GHz)) dB Maxi
Voltage rating		<b>500</b> Veff Maxi
Dielectric withstanding voltage		<b>1500</b> Veff mini
Insulation resistance		<b>5000</b> MΩ mini

**CABLE ASSEMBLY**

Stripping	a	b	c	d	e	f
mm	4,00	8,50	16,5	0,00	12,5	0,00

Assembly instruction : **Crimp 01**

Recommended cable(s)desnor  
RG 58  
KX 15

Characteristics indicated on this data sheet are those that can be achieved with the highest performance cable. Intrinsic limitations of the cable may diminish the performance of the assembly

Cable retention

- pull off **90** N mini  
- torque **NA** N.cm

**MECHANICAL CHARACTERISTICS**

Center contact retention		
Axial force – Mating end	<b>10</b>	N mini
Axial force – Opposite end	<b>10</b>	N mini
Torque	<b>NA</b>	N.cm mini

**TOOLING**

Part Number	Description	Hexagon
R282.293.000	CRIMPING TOOL M22520/5-01	
R282.235.011	CRIMPING DIES M22520/5-11	5.41
R282.223.000	CRIMPING TOOL	5.41

Recommended torque		
Mating	<b>NA</b>	N.cm
Panel nut	<b>NA</b>	N.cm
Clamp nut	<b>NA</b>	N.cm
A/F clamp nut	<b>0,0000</b>	mm

Mating life	<b>100</b>	Cycles mini
Weight	<b>10,3800</b>	g

**OTHER CHARACTERISTICS**

**ENVIRONMENTAL**

Operating temperature	<b>-40/+85</b>	° C
Hermetic seal	<b>NA</b>	Atm.cm3/s
Panel leakage	<b>NA</b>	

Issue : 1233 A

In the effort to improve our products, we reserve the right to make changes judged to be necessary.

