

Units: mm

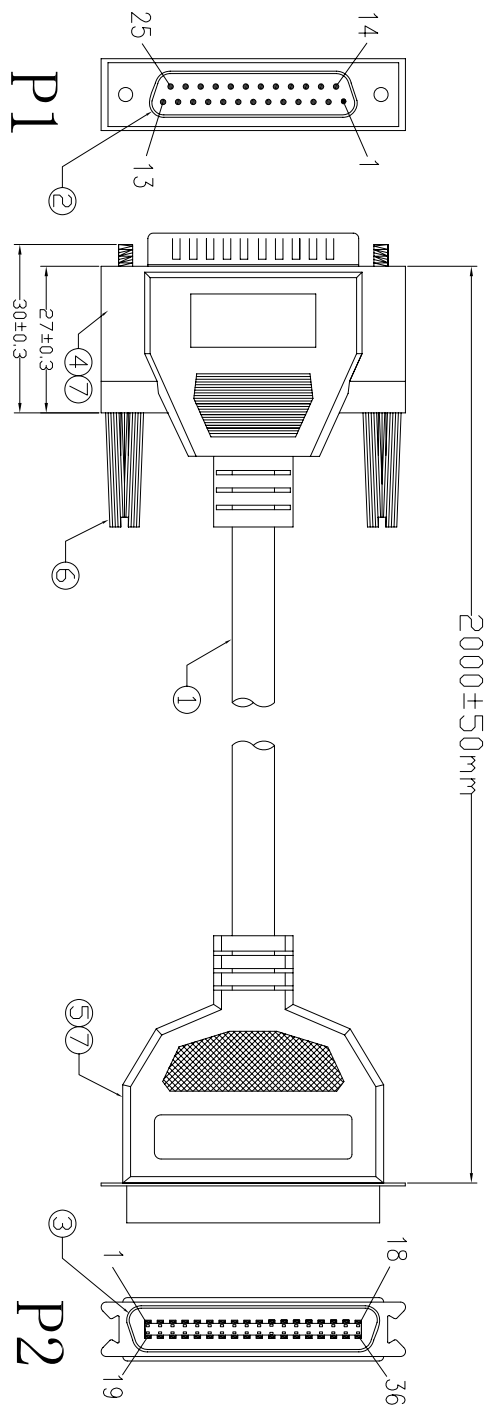

Electrical test:
 1. 100% short, open, miswire test
 2. Conduct resistance: 2 Ohm(max)
 3. Insulation resistance: 5Mohm(min)
 4. dielectric test: DC 300V

⑩	TIE	1	WHITE L=120mm
⑨	PE BAG	1/10	CLEAR SIZE: 360*380*0.05mm PRINT BLACK"MADE IN CHINA "+"10PCS" 及印生产日期,有透气孔.
⑧	PE BAG	1	CLEAR SIZE: 150*280*0.05mm PRINT BLACK"MADE IN CHINA "+"1PC"及印生产日期,有透气孔.
⑦	TUBE	2	HEAT SHRINK TUBE BLACK OD1.5*20MM
⑥	SCREW	2	#4-40UNC TYPE L=30mm,NICKEL PLATED,MOLD:BEIGE(V-29) ABS
⑤	IN JACKET	99	CLEAR LD-PE (Mould NO.:NM-62)
	OUT JACKET	30g	BEIGE(V-29) 40P PVC(Mould NO.WM-145)
	IN JACKET	9g	CLEAR LD-PE (Mould NO.:NM-33)
④	OUT JACKET	30g	BEIGE(V-29) 40P PVC(Mould NO.WM-071)
③	CONN	1	CN 36P MALE SODER TYPE PIN G/F SHELL NI-PLATED INSULATOR COLOR:BLUE
②	CONN	1	DB 25P MALE SODER TYPE PIN G/F SHELL NI-PLATED INSULATOR COLOR:BLUE
①	CABLE	1	NOUL 30#(7/0.10)*25C+D+AL/MY OD6.5mm JACKET BEIGE(V-29) L=2000±15MM
NO.	NAME	Q'TY	SPECIFICATION

PIN ASSIGNMENT	
P1	P2
1	1
2	2
3	3
4	4
5	5
6	6
7	7
8	8
9	9
10	10
11	11
12	12
13	13
14	14
15	15
16	16
17	17
18	18
19	19
20	20
21	21
22	22
23	23
24	24
25	25
SHELL	SHELL

CnC Tech, LLC
 Industrial Cable and Connector Technology

DRAWN BY	ZHONGHS	DARWING NO.
CHECKED BY		CUSTOMER
APPROVAL BY		ITEM NO.
DECIDE BY		DATE
VERSIONS/EDITION	A/0	PROJECTION

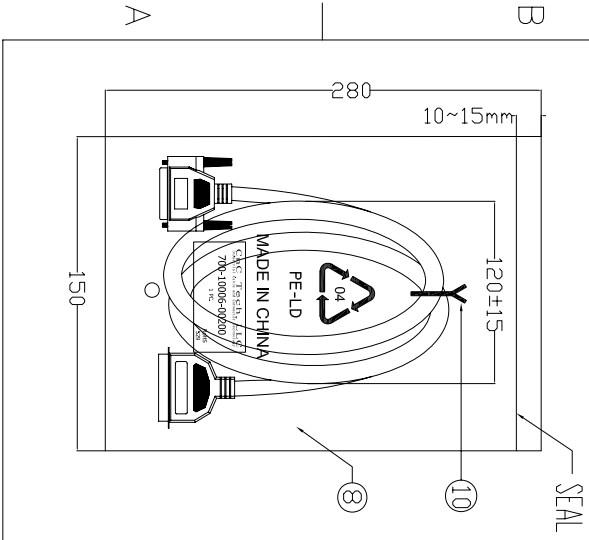

4 3 2 1 1 2 3 4