

DO NOT SCALE FROM THIS PRINT

DIN7A-PP-C-XX-ST-CA6X-X

SERIES
7A: 75 OHM DIN 1.0/2.3

STYLE
-P: PUSH PULL

GENDER
-P: PLUG

TYPE
-C: CABLE

PACKAGING
-BLANK: INDIVIDUAL BAGGED
-B: BULK PACKAGED (QTY=100 MAX)

TERMINATION
-CA6: CCA-6
CCA-1694A
-CA6B: CCA-4694R

ORIENTATION
-ST: STRAIGHT

PLATING SPECIFICATION
-HH: 30µ" GOLD CENTER CONTACT AND OUTER CONTACT
100µ" Ni MIN OTHER
-HF: 30µ" GOLD CENTER CONTACT, 3µ" GOLD OUTER CONTACT
100µ" Ni MIN OTHER
-GG: 10µ" GOLD CENTER CONTACT, AND OUTER CONTACT
100µ" Ni MIN OTHER
-GF: 10µ" GOLD CENTER CONTACT, 3µ" GOLD OUTER CONTACT
100µ" Ni MIN OTHER
(SEE TABLE 1)

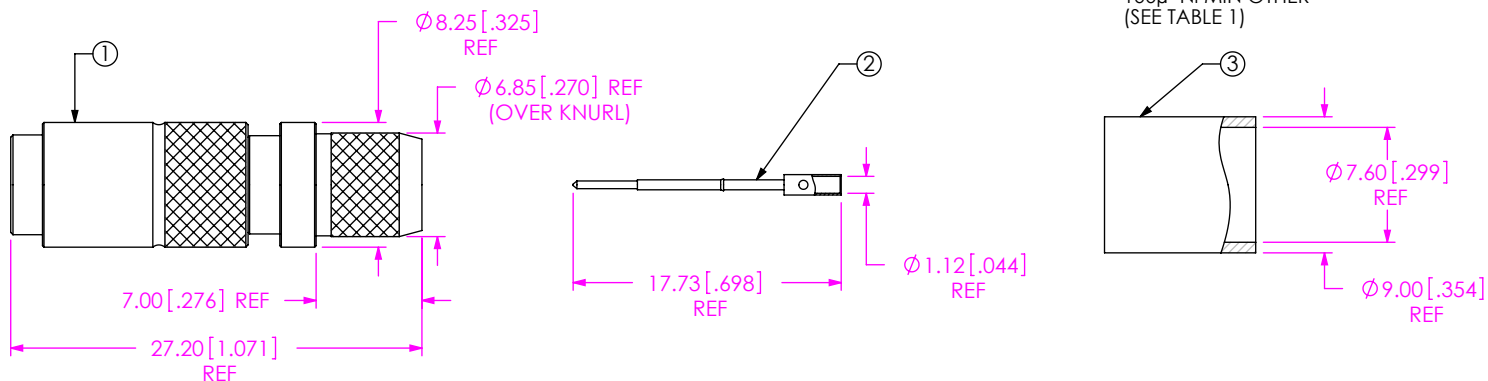

TABLE 1

ITEM	COMPONENT	-HH	-HF	-GG	-GF
1	SUB ASSEMBLY (SEE TABLE 2)	SUB-DIN7A-PP-C-HN-ST-CA6X	SUB-DIN7A-PP-C-FN-ST-CA6X	SUB-DIN7A-PP-C-GN-ST-CA6X	SUB-DIN7A-PP-C-FN-ST-CA6X
2	PIN	DIN7A-P-C-H-ST-CA6-PIN	DIN7A-P-C-H-ST-CA6-PIN	DIN7A-P-C-G-ST-CA6-PIN	DIN7A-P-C-G-ST-CA6-PIN
3	FERRULE	BNC-FER-001-N			

TABLE 2

OPTION	SUB ASSEMBLY
-CA6	SUB-DIN7A-PP-C-XX-ST-CA6
-CA6B	SUB-DIN7A-PP-C-XX-ST-CA6B

NOTES:

1. REPRESENTS A CRITICAL DIMENSION.
2. CENTER CONTACT PUSHOUT FORCE: 26.69 N [6 LB] MIN.
3. DELETED.
4. PRODUCT TO BE PACKAGED PER PRECISION RF SECTION OF PACKAGING MANUAL.
5. DELETED.
6. DELETED.
7. DELETED.

UNLESS OTHERWISE SPECIFIED, DIMENSIONS ARE IN MILLIMETERS [INCHES]. TOLERANCES ARE:

DECIMALS ANGLES
X.X: ±0.3 [.01] 5°
X.XX: ±0.13 [.005]
X.XXX: ±0.051 [.0020]

PROPRIETARY NOTE
THIS DOCUMENT CONTAINS CONFIDENTIAL AND PROPRIETARY INFORMATION AND ALL DESIGN, MANUFACTURING, REPRODUCTION, USE, PATENT RIGHTS AND SALES RIGHTS ARE EXPRESSLY RESERVED BY SAMTEC, INC. THIS DOCUMENT SHALL NOT BE DISCLOSED, IN WHOLE OR PART, TO ANY UNAUTHORIZED PERSON OR ENTITY NOR REPRODUCED, TRANSFERRED OR INCORPORATED IN ANY OTHER PROJECT IN ANY MANNER WITHOUT THE EXPRESS WRITTEN CONSENT OF SAMTEC, INC.

MATERIAL: DO NOT SCALE DRAWING SHEET SCALE: 2:1

SHELL, FERRULE: BRASS
CONTACT: BRASS
GASKET: SILICONE
DIELECTRIC: PTFE



520 PARK EAST BLVD, NEW ALBANY, IN 47150
PHONE: 812-944-6733 FAX: 812-948-5047
e-Mail: info@SAMTEC.com code: 55322

DESCRIPTION:
TRUE 75 OHM, DIN ST PLUG, CCA-6

DWG. NO.
DIN7A-PP-C-XX-ST-CA6X-X

BY: TALON Z 23/12/2010 SHEET 1 OF 3

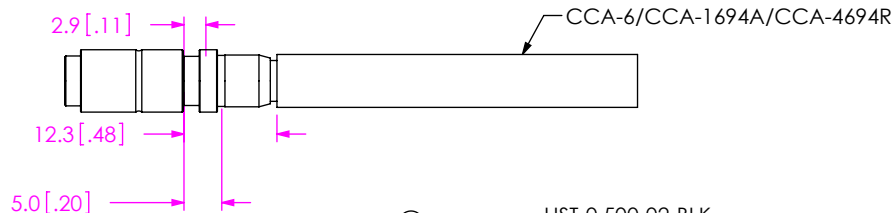

IN-PROCESS 1
STRIP AND TIN INNER CONDUCTOR

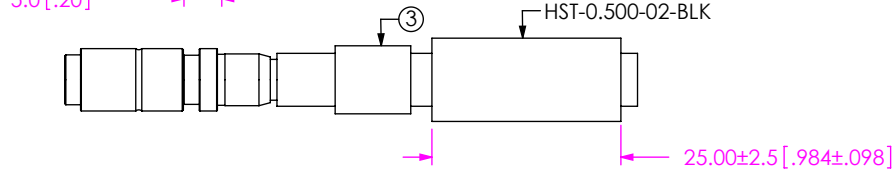

IN-PROCESS 2
ADD HEAT SHRINK TUBE AND FERRULE

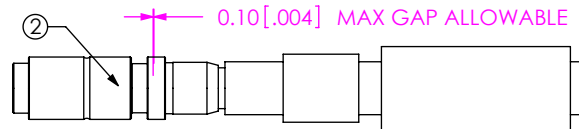

IN-PROCESS 3
SOLDER SIGNAL PIN

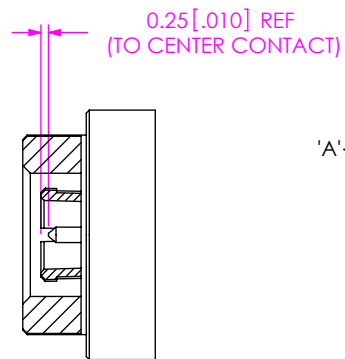

DETAIL 'A'
SCALE 4:1

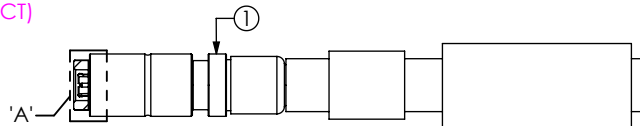

IN-PROCESS 4
FLARE BRAIDED SHIELD AND ADD SUB-DIN7A-PP-C-XX-ST-CA6X
CABLE FOIL WRAP TO BE INSERTED INSIDE CABLE BODY

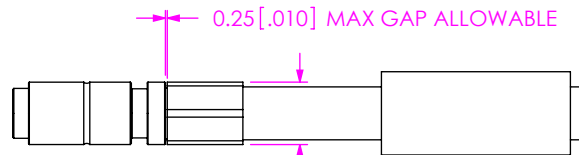

IN-PROCESS 5
CRIMP FERRULE
(USE .324" HEX DIE)
(USE .325 HEX DIE FOR CCA-4694R CABLE)

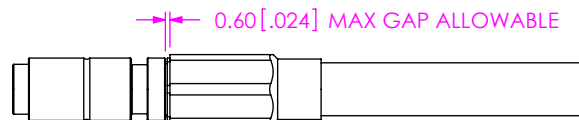

IN-PROCESS 6
APPLY HEAT SHRINK TUBE

PROPRIETARY NOTE
THIS DOCUMENT CONTAINS CONFIDENTIAL AND PROPRIETARY INFORMATION AND ALL DESIGN, MANUFACTURING, REPRODUCTION, USE, PATENT RIGHTS AND SALES RIGHTS ARE EXPRESSLY RESERVED BY SAMTEC, INC. THIS DOCUMENT SHALL NOT BE DISCLOSED, IN WHOLE OR PART, TO ANY UNAUTHORIZED PERSON OR ENTITY NOR REPRODUCED, TRANSFERRED OR INCORPORATED IN ANY OTHER PROJECT IN ANY MANNER WITHOUT THE EXPRESS WRITTEN CONSENT OF SAMTEC, INC.

DO NOT SCALE DRAWING

SHEET SCALE: 1.25:1



520 PARK EAST BLVD, NEW ALBANY, IN 47150
PHONE: 812-944-6733 FAX: 812-948-5047
e-Mail: info@SAMTEC.com code: 55322

DESCRIPTION:
TRUE 75 OHM, DIN ST PLUG, CCA-6

DWG. NO.
DIN7A-PP-C-XX-ST-CA6X-X

BY: TALON Z 23/12/2010 SHEET 2 OF 3

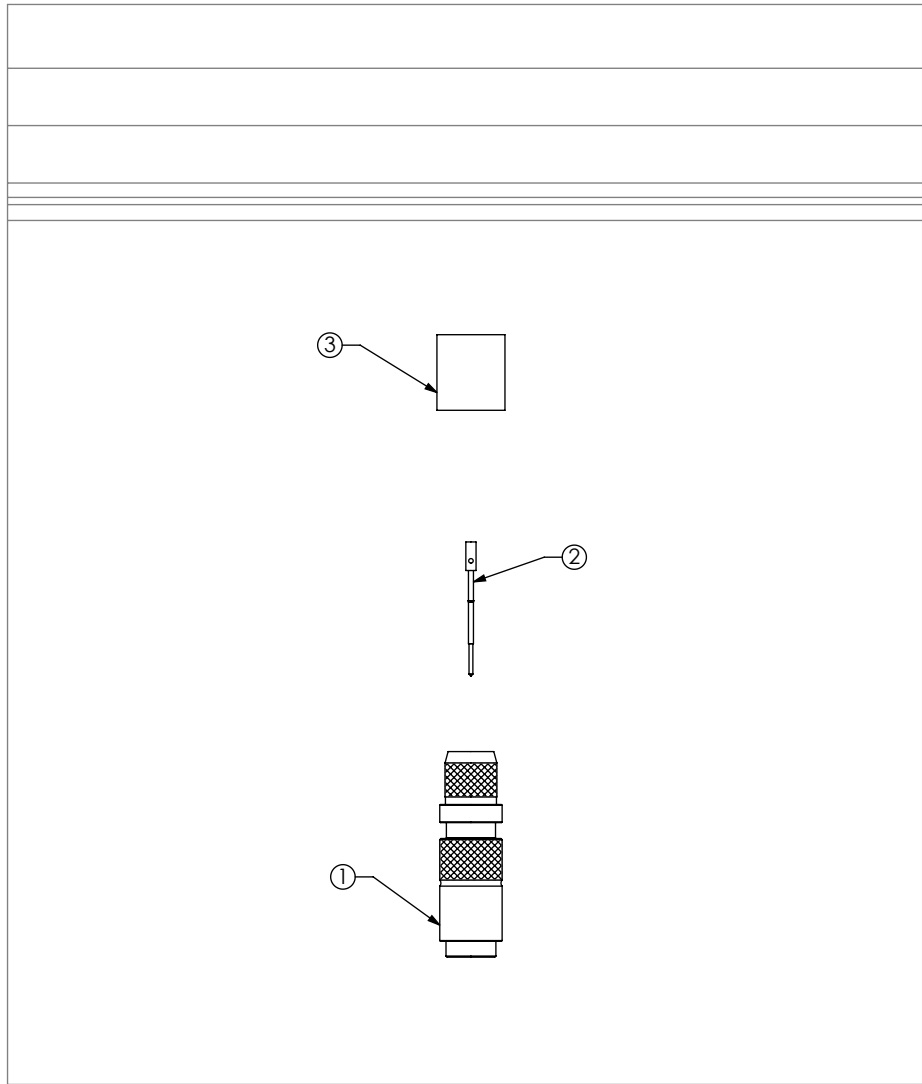

DIN7A-PP-C-XX-ST-CA6X SHOWN

PROPRIETARY NOTE
 THIS DOCUMENT CONTAINS CONFIDENTIAL AND PROPRIETARY INFORMATION AND ALL DESIGN, MANUFACTURING, REPRODUCTION, USE, PATENT RIGHTS AND SALES RIGHTS ARE EXPRESSLY RESERVED BY SAMTEC, INC. THIS DOCUMENT SHALL NOT BE DISCLOSED, IN WHOLE OR PART, TO ANY UNAUTHORIZED PERSON OR ENTITY NOR REPRODUCED, TRANSFERRED OR INCORPORATED IN ANY OTHER PROJECT IN ANY MANNER WITHOUT THE EXPRESS WRITTEN CONSENT OF SAMTEC, INC.

DO NOT SCALE DRAWING

SHEET SCALE: 1.25:1



520 PARK EAST BLVD, NEW ALBANY, IN 47150
 PHONE: 812-944-6733 FAX: 812-948-5047
 e-Mail: info@SAMTEC.com code: 55322

DESCRIPTION:
 TRUE 75 OHM, DIN ST PLUG, CCA-6

DWG. NO.
DIN7A-PP-C-XX-ST-CA6X-X

BY: TALON Z 23/12/2010 SHEET 3 OF 3