



10/100BASE-TX/FX Mini- Φ ™ Transceiver

FEATURES

- Power Supply: 2.5V or 3.3V
- Integrated voltage regulator to allow operation from a single supply source
- Power Consumption: <175 mW
- Unique energy detection circuit to enable intelligent power management
- HP Auto-MDIX
- Cable length indication
- Cable noise level indication
- Robust CESD tolerance
- Cable length greater than 145 meters
- Well under 10 PPM defect ratio quality
- $\pm 10\%$ voltage tolerance
- Industrial temperature range (-40°C to 85°C) package options available
- MII and RMIi configurable
- IEEE 1149.1 (JTAG) scan chain support
- MII management via serial port
- Layout compatible with BCM5201
- 10BASE-T/100BASE-TX/FX IEEE 802.3u Fast Ethernet transceiver
- Glueless TX-to-FX media conversion
- 64-pin TQFP with 64-pin BGA package, 48-pin KML package; RoHS 5/6 and 6/6 package options available

SUMMARY OF BENEFITS

- Low power and intelligent power management
 - Increased active working time
 - Prolonged battery life in active standby
 - Increased reliability
- Improved ease of use and installation, reduced support cost
 - Straight-through or crossover cables are accommodated, and such accommodation is independent of installation
 - Advanced cable diagnostic features to enable remote monitoring and debug of cabling infrastructure
 - Resistance to cable-sourced electrostatic discharge (CESD) to reduce product destruction and product returns
- DSP-based Signi-PHY™ architecture to ensure performance over temperature, voltage, and process variation
 - Proven in over two billion Fast Ethernet ports
- Ease of manufacturing with JTAG support
- Fully integrated TX/FX PHY transceiver (MII/RMIi-to-TX magnetics or FX optics)
 - Lower system cost
 - Simplified system and board design

APPLICATIONS

- Servers - Network Controller - Sideband Interface (NC-SI) using RMIi interface
- Digital TV, PCMCIA/CardBus cards, LAN on motherboard (LOM), IP phones, cable modems, set-top boxes and print servers, wireless access points, and embedded telecom

Embedded 10/100 BASE-TX Application

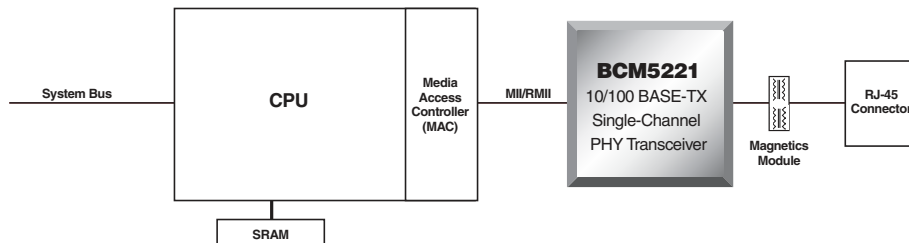

OVERVIEW

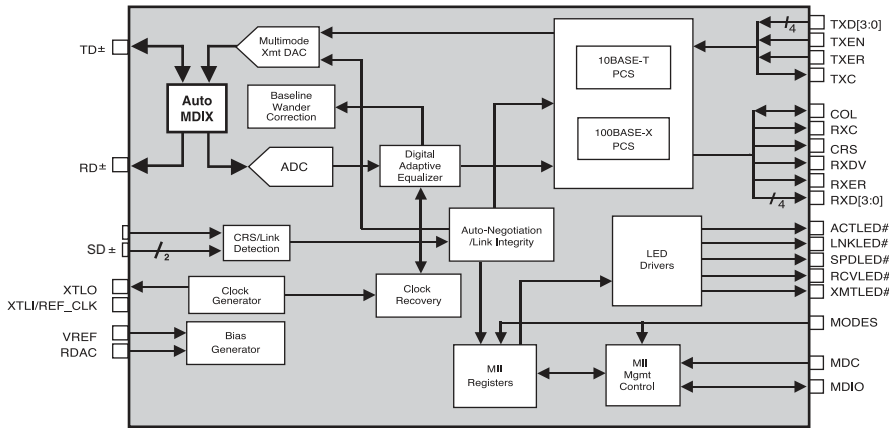

BCM5221 Block Diagram

The BCM5221: Lowest-Power Fast Ethernet PHY

With a power dissipation of 175 mW, the BCM5221 is the industry’s lowest-power Fast Ethernet PHY. It features an integrated voltage regulator, and can be supplied by either a 2.5V or 3.3V power source. In addition, the BCM5221 has several intelligent power-down states that conserve power, yet allow products based on it to automatically turn on when needed.

The BCM5221 includes a unique Intelligent Power-Management feature that powers down the device if energy is not detected on the cable. This feature is especially useful for portable and power-sensitive applications such as laptop LAN card adapters. The BCM5221 allows PCMCIA or CardBus adapters to remain plugged in and draw virtually no energy even if the client is no longer connected to the network. Because most laptop users do not remove their LAN PC card when working remotely, this feature results in a noticeably extended battery life for laptop computer users.

The BCM5221 can be set to periodically wake up at a user-defined interval, allowing the product to initiate keep-alive traffic on the network. For lowest power consumption, the BCM5221 can be put in a power-off state (<2.5 mW).

Network Tolerance

The BCM5221 includes features that simplify the installation and maintenance of local area networks. One such feature is the HP Auto-MDIX capability, which automatically detects and corrects crossed cables. With HP Auto-MDIX, the installer does not need to know what is on the other end of the network cable: the BCM5221 automatically switches its transmit and receive circuitry to accommodate the link partner’s polarity.

Broadcom®, the pulse logo, Connecting everything®, the Connecting everything logo, Signi-PHY™, and Digi-Φ™ are among the trademarks of Broadcom Corporation and/or its affiliates in the United States, certain other countries and/or the EU. Any other trademarks or trade names mentioned are the property of their respective owners.



CESD is a recently discovered phenomenon that occurs when an electrically charged network cable is plugged into a networked product, an issue becoming more prevalent with recent cable installations. The BCM5221 has been designed and tested to withstand over 5 KV of CESD which, unlike other transceivers, prevents the device from being destroyed in a CESD event.

DSP-Based PHY Technology

The BCM5221 builds on Broadcom’s proven DSP PHY design and full custom circuit design techniques to create a highly integrated and robust physical layer solution. DSP techniques allow the BCM5221 to achieve high interoperability and to exhibit robust performance across voltage (±10%), temperature (-40°C to 85°C), and process variations. Broadcom’s DSP-based, Digi-Φ™ technology has been proven in the shipment of over two billion Fast Ethernet ports. Broadcom’s superior quality has resulted in a failure rate well under 10 PPM.

Applications

Applications for the BCM5221 that take advantage of its low power and high network tolerance:

- Servers - Network Controller - Sideband Interface (NC-SI) using RMIi interface
- Digital TV
- PCMCIA/CardBus cards
- LAN on motherboard (LOM)
- IP phones
- Cable modems
- Set-Top boxes
- Print servers
- Wireless Access Points (WAP)
- Embedded telecom



BROADCOM CORPORATION
5300 California Avenue
Irvine, California 92617

Phone: 949-926-5000
Fax: 949-926-5203
E-mail: info@broadcom.com
Web: www.broadcom.com

© 2008 by BROADCOM CORPORATION. All rights reserved.