

# MCU Cards

for **BIGdsPIC6™** development system

Manual

*All Mikroelektronika's development systems feature a large number of peripheral modules expanding microcontroller's range of application and making the process of program testing easier. In addition to these modules, it is also possible to use numerous additional modules linked to the development system through the I/O port connectors. Some of these additional modules can operate as stand-alone devices without being connected to the microcontroller.*

Additional Board

 **MikroElektronika**

SOFTWARE AND HARDWARE SOLUTIONS FOR EMBEDDED WORLD ...making it simple

## MCU Cards for BIGdsPIC6 Development System

The BIGdsPIC6 development system is supported by empty 64- and 80-pin MCU cards. Schematics provided herein show these MCU cards with soldered microcontrollers. Instead of microcontrollers used in these examples, you can choose and solder another ones. Prior to soldering, check which microcontrollers can be placed on the respective MCU card just to be sure that they are compatible. MCU cards are also provided with pads that enables you to access microcontroller pins when the MCU card is not connected to the development system.

Supported microcontrollers:

64-pin MCU cards support the following microcontrollers: U1: dsPIC30F6012A-PT, dsPIC30F6011A-PT and dsPIC30F5011-PT; U2: dsPIC30F5015-PT and dsPIC30F6015-PT.

80-pin MCU cards support the following microcontrollers in TQFP1 package: dsPIC30F6014A-PT, dsPIC30F6013A-PT and dsPIC30F5013-PT.

80-pin MCU cards support the following microcontrollers in TQFP2 package: dsPIC30F5016-PT and dsPIC30F6010A-PT.

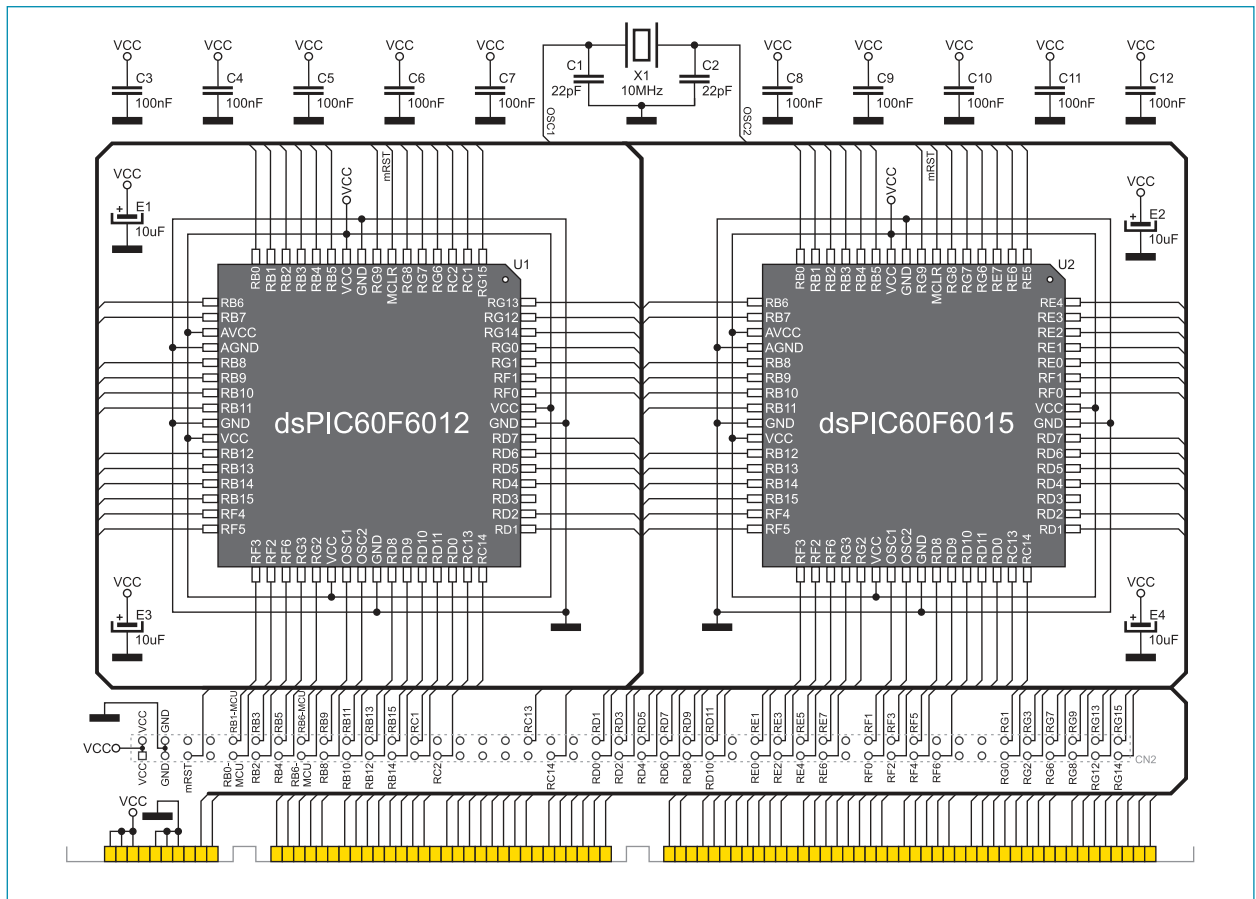

Figure 1: 64-pin MCU card and microcontroller connection schematic



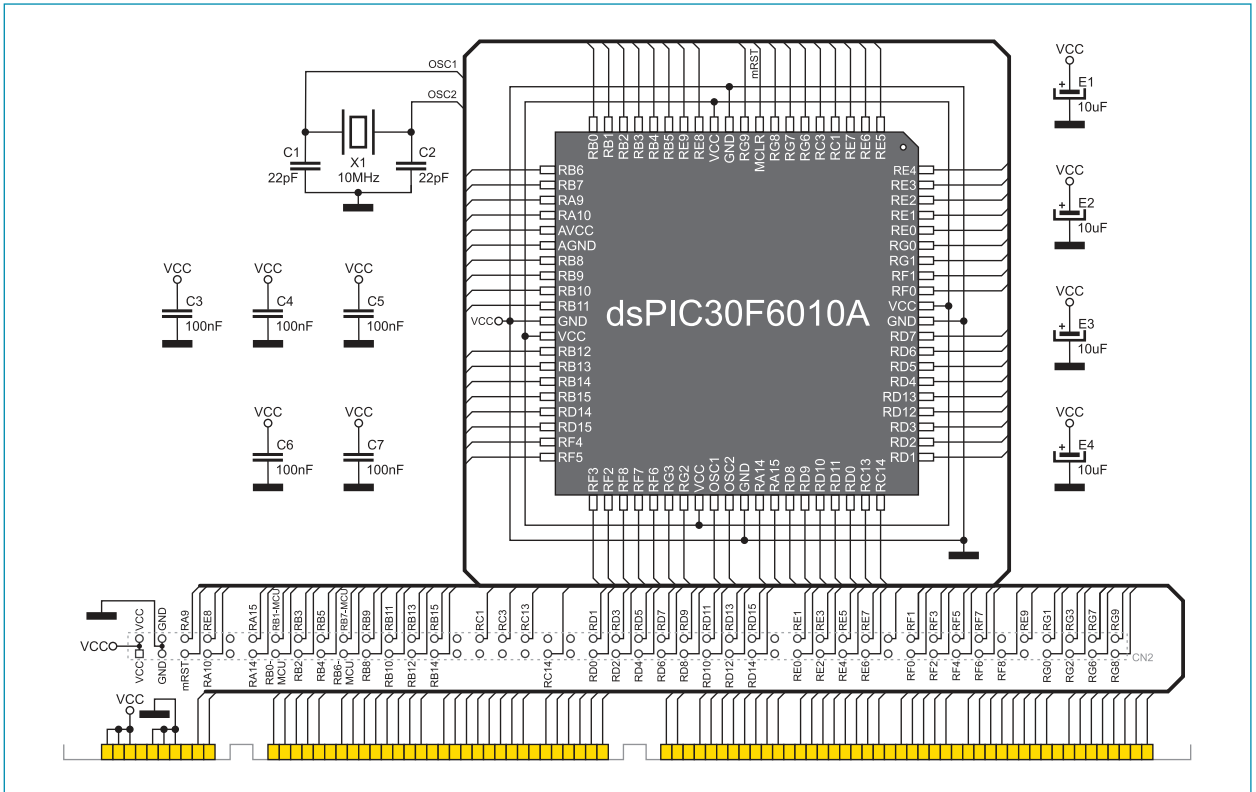

Figure 4: 80-pin MCU card and microcontroller connection schematic (TQFP2)

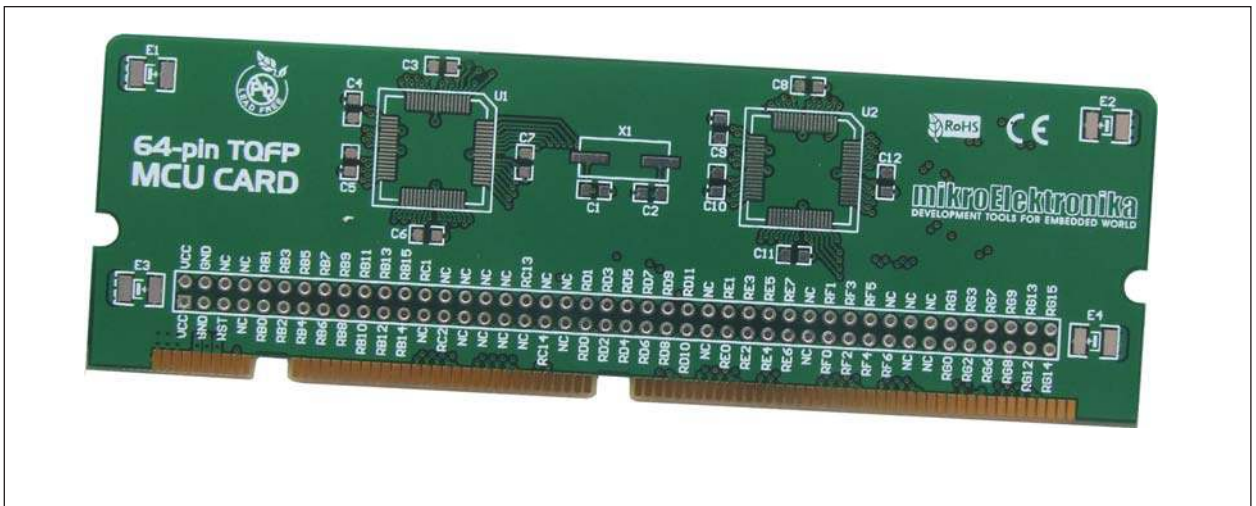

Figure 5: Empty 64-pin MCU card





**MikroElektronika**  
SOFTWARE AND HARDWARE SOLUTIONS FOR EMBEDDED WORLD ...making it simple

If you want to learn more about our products, please visit our website at [www.mikroe.com](http://www.mikroe.com)

If you are experiencing some problems with any of our products or just need additional information, please place your ticket at [www.mikroe.com/en/support](http://www.mikroe.com/en/support)

If you have any questions, comments or business proposals, do not hesitate to contact us at [office@mikroe.com](mailto:office@mikroe.com)