



ORBEL CORPORATION

EZ-SHIELD™ STANDARD PRODUCT FEATURES

- Unlimited shield sizes
- Variety of material options
- Surface mount and through hole configurations
- Many fence/cover retention methods
- Variety of pin & surface mount styles
- Mouse holes for traces to enter and exit shields at no extra cost
- Standard ventilation holes for thermal consideration
- EZ-Marking - part number and logos identification
- Standard pick target for pick and place
- Available with EZ-Bend forming lines
- ITAR and ISO9001 Approved
- RoHS Compliant

EZ-Shield™ (BLS) Board Level Shielding *Shielding Tomorrow's Technology*

Orbel Corporation is the recognized leader in standard and custom (BLS) Board Level Shielding technology. We offer a wide selection of one-piece, two-piece and multi-cavity RF shielding. Our Snap-Shield and Vault-Shield products offer unlimited design flexibility and are suited for surface mount or through-hole applications. Our expertise in EMI suppression and precision metal forming allows us to transform your shielding ideas into practical (BLS) Board Level Shielding solutions.

By utilizing our standard universal tooling, designers can build custom configured shields with minimum startup costs. You simply select from a list of many standard product features you wish to incorporate into your shield design and the rest is made easy by Orbel. These standard shields are available from a variety of material options with shield heights ranging from 0.058" to 2.00".

Snap Shield ▶

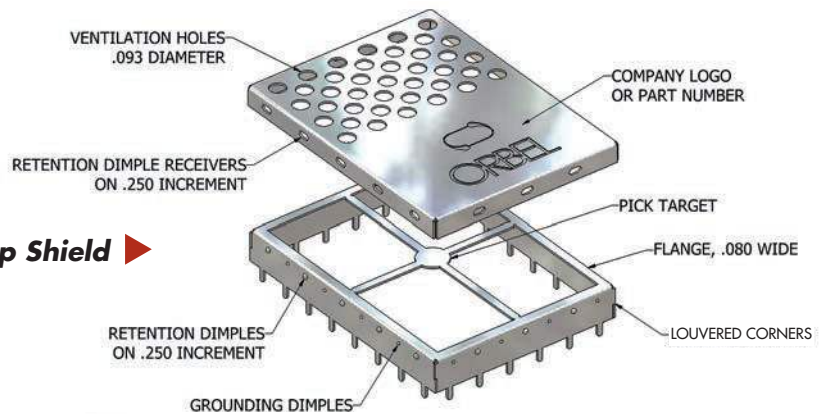

◀ Vault Shield

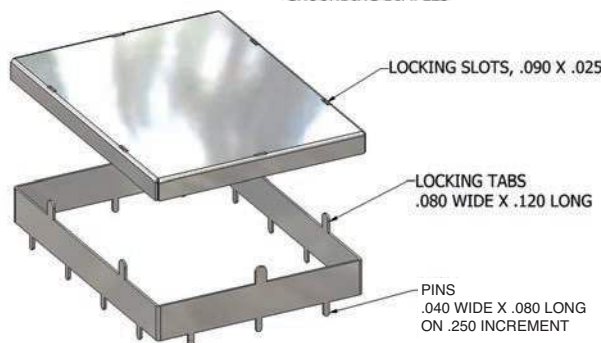

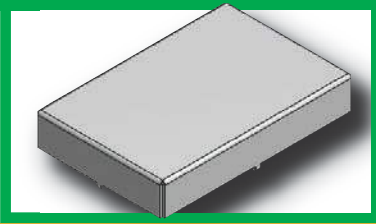

EZ-SHIELD GUARDIAN™

The Guardian™ is a one-piece circuit board shield available in a through-hole or surface mount design. It is intended for inaccessibility to components, where cost is important.

- Shield heights range from: 0.030" to 2.00"
- Material thicknesses: 0.008", 0.010" and 0.015"
- Alignment pins are centrally located on each side
- Standard tight corners

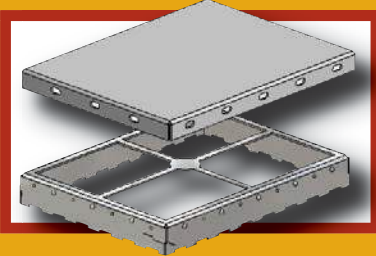

SNAP-SHIELD BULLZEYE™

The Bullseye™ is a two-piece surface mount shield design with castellated edges for ease of soldering & trace-pass through. The Bullseye offers a pick target for pick & place automation, with added part stability to achieve maximum coplanarity in the reflow process.

- Shield heights range from 0.090" to 2.00"
- Pick target for pick and place automation
- Castellated edge for ease of soldering and trace-pass
- Louvered corners for high RF integrity

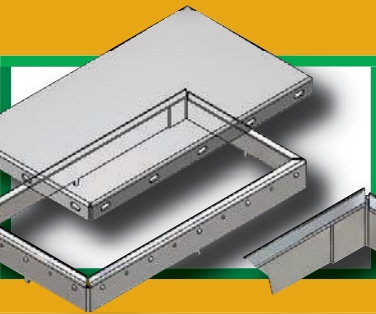

SNAP-SHIELD LAZERLOC™

The LaZerLoc™ is a two-piece shield available in a through-hole or surface mount design. The LaZerLoc offers zero corner slots for high RF integrity when specifying larger and more complicated shields in hand placement applications.

- Shield heights range from 0.090" to 2.00"
- Fully welded frame, no corner seams
- Standard 0.080" flange on fence increases shield rigidity
- Standard dimple & slot cover retention

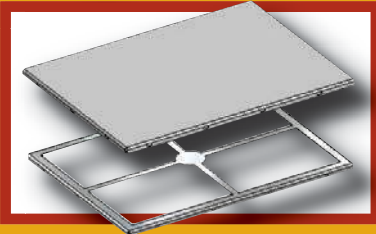

SNAP-SHIELD MICRO™

The Micro™ offers the lowest two-piece surface mount shield assembly in the industry. Micro shields are ideal when space is limited but a two piece shield is required. The Micro offers a pick target for pick & place automation, with added part stability to achieve maximum co-planarity.

- Shield heights range from 0.058" to 0.100"
- Standard pick target for pick and place automation
- Mini dimple & slot cover retention method
- Standard with tight corners

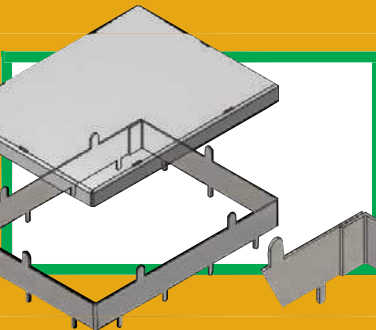

VAULT-SHIELD™

The Vault-Shield™ is a two-piece through-hole shield design used primarily in extreme shock and vibration applications. The Vault-Shield's tab and slot retention method provides the added security of the best cover-to-frame retention available in the market.

- Shield heights range from 0.030" to 2.00"
- Fully welded frame, no corner seams
- Standard tab and slot retention method
- Material thicknesses 0.008", 0.010" and 0.015"

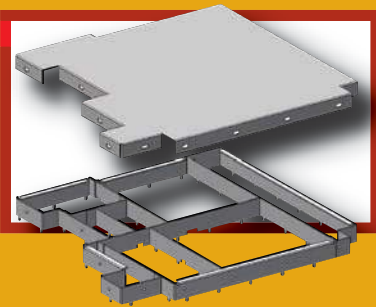

MULTICAV™

The MultiCAV™ is a compartmentalized shield that combines multiple shields into one to save valuable board space while reducing shield weight and overall costs. The MultiCAV products typically come in a two-piece construction with inner walls strategically placed while utilizing one common cover.

- Shield heights range from: 0.075" to 2.00"
- Standard dimple & slot cover retention
- Customized to your board trace specifications
- Locking tabs for grounding the inner walls and cover