

NOTES:

1. RECOMMENDED SOLDER INSTRUCTION SEE SHEET 2
2. METALSHELLS: COPPER ALLOY; min. 315µin TIN over 40-80µin NICKEL
3. INSULATORS: PBT GF UL 94 V-0, GREEN
4. SIGNAL CONTACTS: COPPER ALLOY
PLATING: GOLD FLASH over NICKEL
SOLDER CUP ACCEPTS CABLE AWG 20
5. HIGH POWER CONTACTS 10A: COPPER ALLOY
PLATING MATING AREA: GOLD FLASH over NICKEL
SOLDER CUP ACCEPTS CABLE AWG 16-20
6. THREADED LOCKS: COPPER ALLOY; min. 200µin TIN over 80µin NICKEL
7. COLLARS: COPPER ALLOY; min. 200µin TIN over 80µin NICKEL
8. SEALING COMPOUND: PUR; BLUE
9. FRAME: ZINC DIE CAST; NICKEL PLATED
10. O-RING: SILICON; BLUE
11. HEXLOCKING SCREWS: STAINLESS STEEL
12. RECOMMENDED PANEL CUT-OUT SEE SHEET 2
13. RECOMMENDED TORQUE FOR MOUNTING SCREW 35Ncm
(3.1 in.LB) / max.40Ncm (3.5 in.LB)
14. CONNECTOR IS PART MARKED: 6017W2SAM61B50X CONEC ABC

AT ALL TIMES WATER RESISTANT CONNECTORS NOT IN USE SHOULD BE COVERED WITH A CONEC WATER RESISTANT CAP OR WATER TIGHT HOOD.

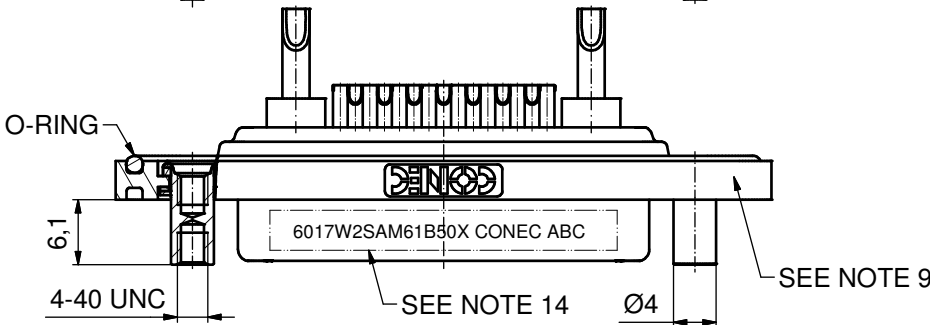
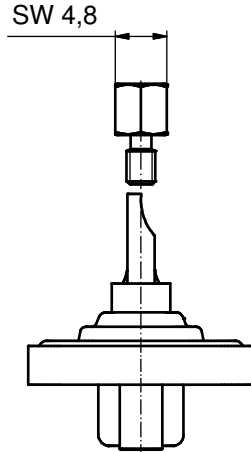
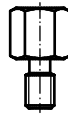
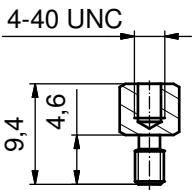
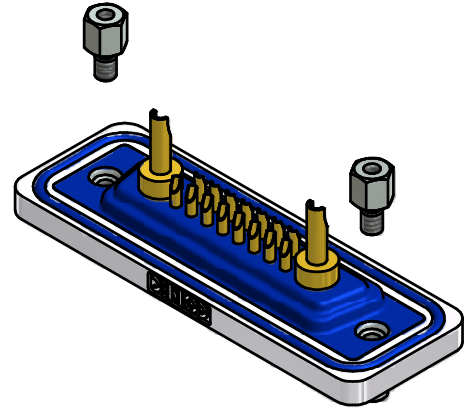
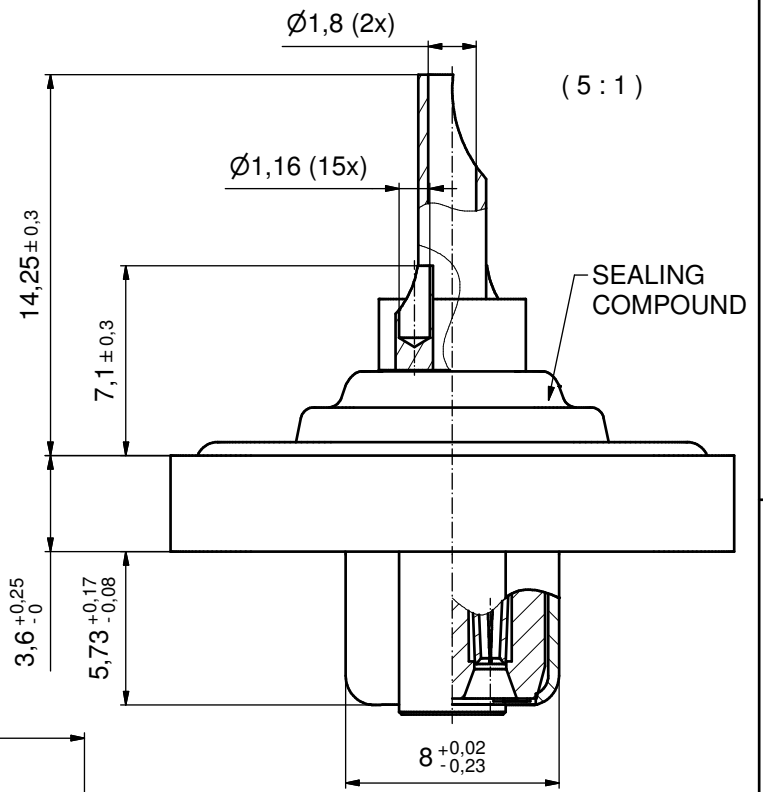
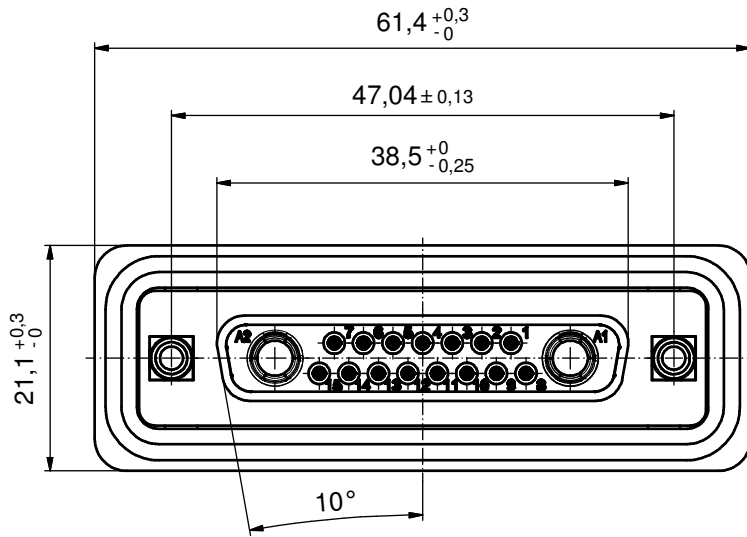

Directive 2002/95/EC
"RoHS"
Compliant

APPROVAL # FREIGABE # DEBLOCAGE # AUTORIZACION # APPROVAL	
CUSTOMER APPROVAL DATE:	
NAME:	TITLE:
COMPANY NAME:	
APPROVAL # FREIGABE # DEBLOCAGE # AUTORIZACION # APPROVAL	

THIS DRAWING MAY NOT BE COPIED OR REPRODUCED IN ANY WAY, AND MAY NOT BE PASSED ON TO A THIRD PARTY WITHOUT WRITTEN PERMISSION. OWNERSHIP AND COPYRIGHT OF CONEC GmbH DO NOT ALTER CAD DRAWING BY HAND				tolerance		dim. in mm	scale: 2:1 (5:1)	
				date			material: SEE NOTE	
				drawn	29.10.10		name	
				appd.	29.10.10		Fischer	
norm		d-old		D-SUB COMBINATION FEMALE 17W2S SOLDER CUP with threaded lock and hexlocking screw				
a Origin								
rev.	description	date	name	dwg no: Inventor 10		DIN-A3		
				part no: 15K1A741		sh: 1		
				part no: 6017W2SAM61B50X				

Solder Instruction

1. Cable should be prepared for soldering. The cable/wires must be pretinned.
2. Insert cable/wire into solder cup.
3. Signal Contact
 - 3.1. Operate the soldering iron at 350 °C, 50 Watt max. and use a pencil tip.
 - 3.2. Put tip to wire in solder cup.
 - 3.3. After 1 second bring in solder.
 - 3.4. Heat for 3 seconds longer. Do not heat contact more than 4 seconds in total.
4. Power Contact
 - 4.1. Operate the soldering iron at 350 °C, 100 Watt max. and use a pencil tip.
 - 4.2. Put tip to wire in solder cup.
 - 4.3. After 1 second bring in solder.
 - 4.4. Heat for 5 seconds longer. Do not heat contact more than 6 seconds in total.
5. Remove soldering iron.
6. Wait until solder gets rigid again.
7. Do not solder adjacent contacts consecutively, alternate position within the connector to minimize heat build up.

RECOMMENDED PANEL CUT-OUT

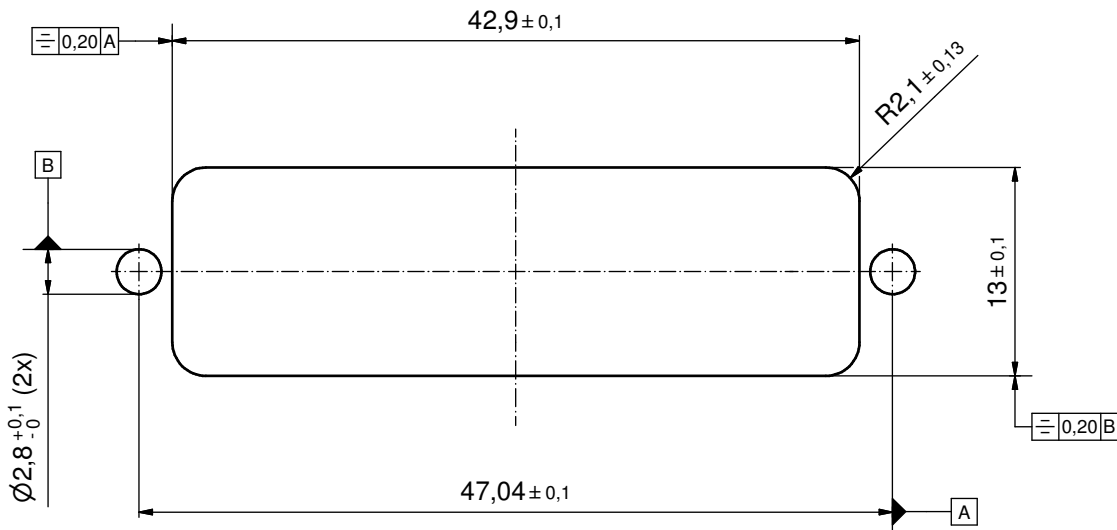

APPROVAL # FREIGABE # DEBLOCAGE # AUTORIZACION # APPROVAL	
CUSTOMER APPROVAL DATE:	
NAME:	TITLE:
COMPANY NAME:	
APPROVAL # FREIGABE # DEBLOCAGE # AUTORIZACION # APPROVAL	

THIS DRAWING MAY NOT BE COPIED OR REPRODUCED IN ANY WAY, AND MAY NOT BE PASSED ON TO A THIRD PARTY WITHOUT WRITTEN PERMISSION. OWNERSHIP AND COPYRIGHT OF CONEC GmbH				tolerance		dim. in mm	scale: 2:1	
				DO NOT ALTER CAD DRAWING BY HAND			material: SEE SHEET 1	
rev.	description	date	name	drawn	29.10.10	Henneboel	title: PANEL CUT-OUT D-SUB COM. FEMALE 17W2S SOLDER CUP with threaded lock and hexlocking screw	
a	Origin			appd.	29.10.10	Fischer		
				norm				
				d-old			dwg no:	Inventor 10
								DIN-A3
								sh: 2
							part no:	SEE SHEET 1

CONEC®