

AT-42010

Up to 6 GHz Medium Power Silicon Bipolar Transistor



Data Sheet

Description

Avago's AT-42010 is a general purpose NPN bipolar transistor that offers excellent high frequency performance. The AT-42010 is housed in a hermetic, high reliability 100 mil ceramic package. The 4 micron emitter-to-emitter pitch enables this transistor to be used in many different functions. The 20 emitter finger interdigitated geometry yields a medium sized transistor with impedances that are easy to match for low noise and medium power applications. This device is designed for use in low noise, wideband amplifier, mixer and oscillator applications in the VHF, UHF, and microwave frequencies. An optimum noise match near 50Ω up to 1 GHz, makes this device easy to use as a low noise amplifier.

The AT-42010 bipolar transistor is fabricated using Avago's 10 GHz f_T Self-Aligned-Transistor (SAT) process. The die is nitride passivated for surface protection. Excellent device uniformity, performance and reliability are produced by the use of ion-implantation, self-alignment techniques, and gold metalization in the fabrication of this device.

Features

- High Output Power:
21.0 dBm Typical P_{1 dB} at 2.0 GHz
20.5 dBm Typical P_{1 dB} at 4.0 GHz
- High Gain at 1 dB Compression:
14.0 dB Typical G_{1 dB} at 2.0 GHz
9.5 dB Typical G_{1 dB} at 4.0 GHz
- Low Noise Figure:
1.9 dB Typical NF_O at 2.0 GHz
- High Gain-Bandwidth Product: 8.0 GHz Typical f_T
- Hermetic Gold-ceramic Microstrip Package

100 mil Package

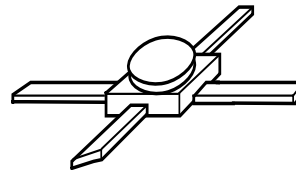

AT-42010 Absolute Maximum Ratings^[1]

Symbol	Parameter	Units	Absolute Maximum
V _{EBO}	Emitter-Base Voltage	V	1.5
V _{CBO}	Collector-Base Voltage	V	20
V _{CEO}	Collector-Emitter Voltage	V	12
I _C	Collector Current	mA	80
P _T	Power Dissipation ^[2,3]	mW	600
T _j	Junction Temperature	°C	200
T _{STG}	Storage Temperature	°C	-65 to 200

Thermal Resistance^[2,4]:

$$\theta_{jc} = 150^{\circ}\text{C/W}$$

Notes:

1. Permanent damage may occur if any of these limits are exceeded.
2. T_{case} = 25°C.
3. Derate at 6.7 mW/°C for T_c > 110°C.
4. The small spot size of this technique results in a higher, though more accurate determination of θ_{jc} than do alternate methods. See MEASUREMENTS section "Thermal Resistance" for more information.

Electrical Specifications, T_A = 25°C

Symbol	Parameters and Test Conditions ^[1]	Units	Min.	Typ.	Max.
S _{21E} ²	Insertion Power Gain; V _{CE} = 8 V, I _C = 35 mA	f = 2.0 GHz f = 4.0 GHz	10.5 5.5	11.5	
P _{1 dB}	Power Output @ 1 dB Gain Compression V _{CE} = 8 V, I _C = 35 mA	f = 2.0 GHz f = 4.0 GHz	20.5	21.0	
G _{1 dB}	1 dB Compressed Gain; V _{CE} = 8 V, I _C = 35 mA	f = 2.0 GHz f = 4.0 GHz	9.5	14.0	
NF ₀	Optimum Noise Figure; V _{CE} = 8 V, I _C = 10 mA	f = 2.0 GHz f = 4.0 GHz	3.0	1.9	
G _A	Gain @ NF ₀ ; V _{CE} = 8 V, I _C = 10 mA	f = 2.0 GHz f = 4.0 GHz	10.0	13.5	
f _T	Gain Bandwidth Product; V _{CE} = 8 V, I _C = 35 mA			8.0	
h _{FE}	Forward Current Transfer Ratio; V _{CE} = 8 V, I _C = 35 mA		30	150	270
I _{CBO}	Collector Cutoff Current; V _{CB} = 8 V				0.2
I _{EBO}	Emitter Cutoff Current; V _{EB} = 1 V				2.0
C _{CB}	Collector Base Capacitance ^[1] ; V _{CB} = 8 V, f = 1 MHz			0.28	

Notes:

1. For this test, the emitter is grounded.

AT-42010 Typical Performance, $T_A = 25^\circ\text{C}$

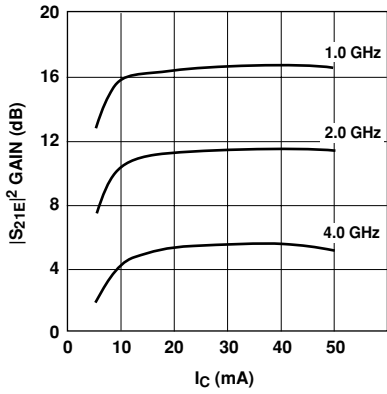

Figure 1. Insertion Power Gain vs. Collector Current and Frequency. $V_{CE} = 8\text{ V}$.

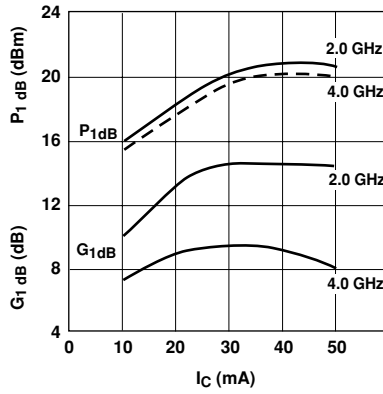

Figure 2. Output Power and 1 dB Compressed Gain vs. Collector Current and Frequency. $V_{CE} = 8\text{ V}$.

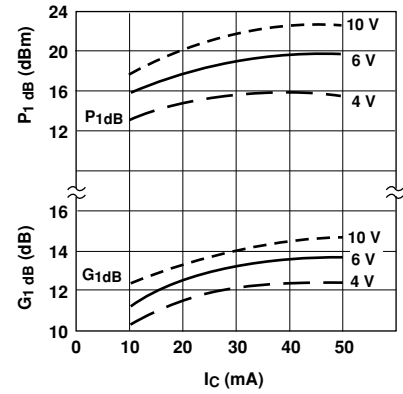

Figure 3. Output Power and 1 dB Compressed Gain vs. Collector Current and Voltage. $f = 2.0\text{ GHz}$.

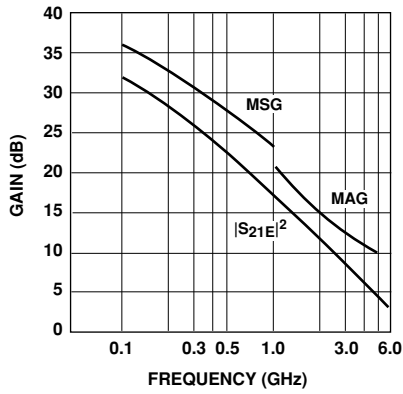

Figure 4. Insertion Power Gain, Maximum Available Gain and Maximum Stable Gain vs. Frequency. $V_{CE} = 8\text{ V}$, $I_C = 35\text{ mA}$.

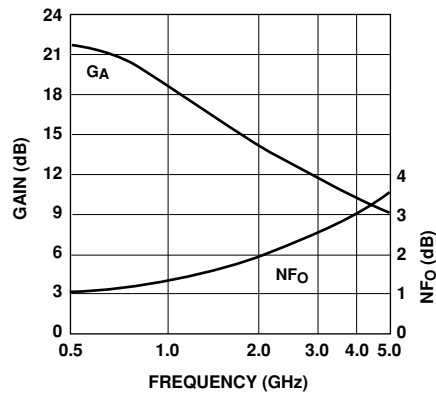

Figure 5. Noise Figure and Associated Gain vs. Frequency. $V_{CE} = 8\text{ V}$, $I_C = 10\text{ mA}$.

AT-42010 Typical Scattering Parameters,

Common Emitter, $Z_0 = 50 \Omega$, $T_A = 25^\circ\text{C}$, $V_{CE} = 8 \text{ V}$, $I_C = 10 \text{ mA}$

Freq. GHz	S_{11}		dB	S_{21}		dB	S_{12}		S_{22}	
	Mag.	Ang.		Mag.	Ang.		Mag.	Ang.	Mag.	Ang.
0.1	.74	-47	28.5	26.65	153	-36.4	.015	72	.91	-18
0.5	.65	-136	21.4	11.71	103	-29.4	.034	38	.51	-39
1.0	.63	-168	15.9	6.24	82	-27.2	.044	36	.40	-42
1.5	.63	174	12.6	4.26	69	-26.0	.050	42	.38	-45
2.0	.63	161	10.1	3.23	57	-24.6	.059	43	.38	-49
2.5	.64	154	8.4	2.64	51	-23.0	.070	52	.38	-51
3.0	.65	145	6.9	2.22	41	-22.0	.080	54	.37	-56
3.5	.66	136	5.8	1.94	31	-21.0	.090	51	.38	-65
4.0	.66	126	4.7	1.72	21	-19.7	.104	50	.39	-74
4.5	.66	115	3.8	1.55	11	-18.0	.126	45	.40	-82
5.0	.66	103	3.0	1.41	1	-17.3	.136	41	.40	-89
5.5	.68	90	2.1	1.28	-9	-16.1	.156	36	.40	-98
6.0	.72	81	1.3	1.16	-19	-15.4	.170	31	.37	-110

AT-42010 Typical Scattering Parameters,

Common Emitter, $Z_0 = 50 \Omega$, $T_A = 25^\circ\text{C}$, $V_{CE} = 8 \text{ V}$, $I_C = 35 \text{ mA}$

Freq. GHz	S_{11}		dB	S_{21}		dB	S_{12}		S_{22}	
	Mag.	Ang.		Mag.	Ang.		Mag.	Ang.	Mag.	Ang.
0.1	.54	-90	33.3	45.97	138	-39.2	.011	54	.76	-29
0.5	.62	-163	22.8	13.83	94	-33.2	.022	52	.34	-40
1.0	.62	177	17.0	7.10	78	-28.8	.036	59	.30	-40
1.5	.62	166	13.6	4.82	67	-26.2	.049	61	.29	-42
2.0	.62	155	11.3	3.65	56	-23.8	.065	57	.29	-47
2.5	.63	150	9.5	2.99	51	-21.8	.081	62	.29	-50
3.0	.64	142	8.0	2.52	42	-21.0	.090	63	.30	-57
3.5	.65	133	6.8	2.19	32	-19.7	.103	59	.30	-67
4.0	.65	124	5.7	1.93	22	-18.4	.120	54	.31	-76
4.5	.65	113	4.7	1.72	13	-17.2	.138	49	.33	-85
5.0	.66	102	3.9	1.56	3	-16.6	.148	45	.34	-92
5.5	.69	91	3.0	1.41	-6	-15.6	.166	39	.33	-100
6.0	.73	83	2.1	1.27	-16	-14.9	.180	32	.30	-110

AT-42010 Noise Parameters: $V_{CE} = 8 \text{ V}$, $I_C = 10 \text{ mA}$

Freq. GHz	NF ₀ dB	Γ_{opt}		R _N /50
		Mag	Ang	
0.1	1.0	.04	15	0.13
0.5	1.1	.05	76	0.12
1.0	1.5	.10	132	0.12
2.0	1.9	.23	-177	0.11
4.0	3.0	.45	-125	0.26

Ordering Information

Part Number	No. of Devices
AT-42010	100

100 mil Package Dimensions

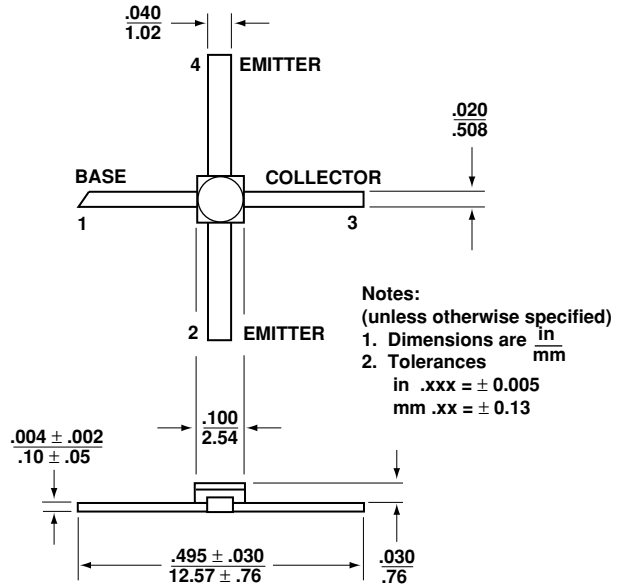

For product information and a complete list of distributors, please go to our web site: www.avagotech.com

Avago, Avago Technologies, and the A logo are trademarks of Avago Technologies, Limited in the United States and other countries. Data subject to change. Copyright © 2008 Avago Technologies Limited. All rights reserved. Obsoletes AV01-0022EN AV02-1217EN April 29, 2008

AVAGO
TECHNOLOGIES