

THIS DRAWING IS UNPUBLISHED. RELEASED FOR PUBLICATION
 © COPYRIGHT BY TYCO ELECTRONICS CORPORATION. ALL RIGHTS RESERVED.

DESIGNED FOR USE WITH
 .085 DIA S.R. CABLE
 CABLE ENTRY DIAMETER
 MINIMUM

CONTACT	.021
HOUSING	.089

LOC	DIST	REVISIONS			
P	LTR	DESCRIPTION	DATE	DWN	APVD
	B	REV PER ECO 07-004710	3/12/2007	DW	KW

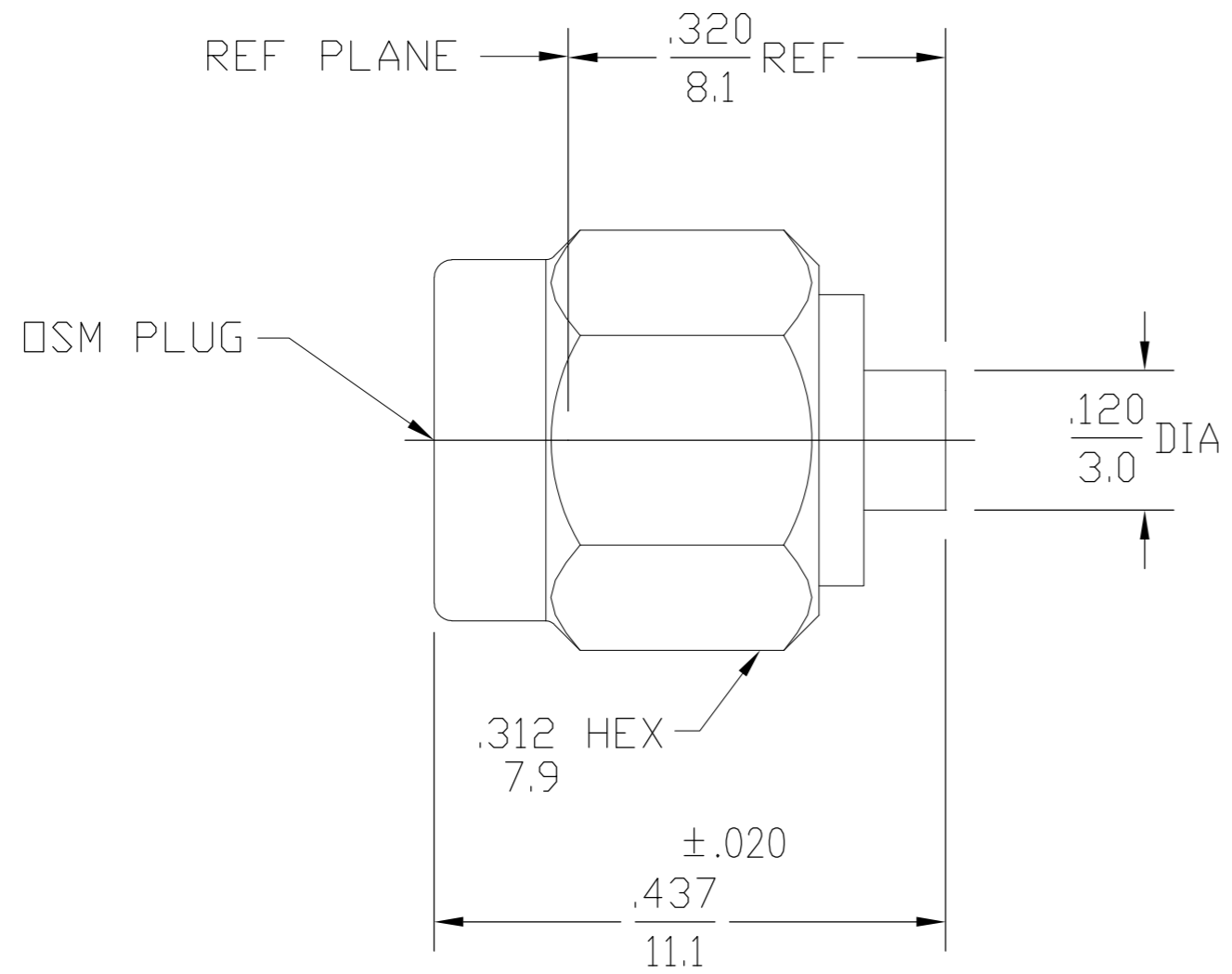

1050769-1
 PART NUMBER

ELECTRICAL	MECHANICAL	ENVIRONMENTAL
Nominal Impedance (Ohms) 50	Interface Dimensions MIL-STD-348, Fig. 310.1	TEMPERATURE RATING -65°C TO 105°C
Frequency Range (GHz) DC to 18.0	Recommended Mating Torque 7 to 10 in-LBs	Vibration MIL-STD-202, Method 204, Condition D
Volt Rating (VRMS MAX) @ Sea Level 335	Mating Characteristics: Insertion (MAX Lbs) N/A	Shock MIL-STD-202, Method 213, Condition I
VSWR 1.05 + .005f(GHz)	Withdrawal (MIN Oz) N/A	Thermal Shock MIL-STD-202, Method 107, Condition B, EXCEPT HIGH TEMP 115°C
Insertion Loss (dB MAX) .03 √f(GHz)	Force to Engage and Disengage (In/Lbs MAX) 2.0	Moisture Resistance MIL-STD-202, Method 106
RF Leakage (dB MIN) -(90-f(GHz))	Center Contact Captivation Axial (Lbs) N/A	Corrosion - MIL-STD-202, Method 101, Condition B, 5% salt spray
Corona, 70,000 Ft (VRMS MIN) 250	Radial (In/Oz) N/A	
Dielectric Withstanding Voltage (VRMS MIN) @ Sea Level 1000	Cable Retention Axial Force (Lbs) 30	
Contact Resistance (Milliohms MAX) Center Contact 2.0	Torque (In/Oz) 16	
Outer Contact 2.0	Weight (Grams) T.B.D.	
Cable to Housing 0.5		
RF High Potential @ Sea Level (VRMS MIN @ 5 MHz) 670		
I.R.(Megohms MIN) 10,000		

.XXX = in
 XX.X = mm

COMPONENT	MATERIAL	FINISH
HOUSING COUPLING NUT	STAINLESS STEEL PER ASTM-A484 AND ASTM-A582, TYPE 303	GOLD PLATE PER MIL-G-45204
DIELECTRIC	TFE FLUOROCARBON PER ASTM-D-1457	N/A
CENTER CONTACT	BERYLLIUM COPPER PER ASTM B 196, ALLOY C17300, CONDITION H OR BRASS PER ASTM-B-16	GOLD PLATE PER MIL-G-45204
RETAINING RING	BERYLLIUM COPPER PER ASTM B 194, ALLOY C17200, CONDITION H	N/A
GASKET	SILICONE RUBBER PER ZZ-R-765	N/A

THIS DRAWING IS A CONTROLLED DOCUMENT.

DWN DRJ 11/1/76	 Tyco Electronics Corporation Harrisburg, PA 17105-3608	NAME	OSM STRAIGHT CABLE PLUG DIRECT SOLDER ATTACHMENT
CHK -		SIZE	A2
APVD RME		CAGE CODE	00779
PRODUCT SPEC		DRAWING NO	C=1050769
APPLICATION SPEC	RESTRICTED TO	-	
WEIGHT -	SCALE	5:1	SHEET 1 of 1
CUSTOMER DRAWING	REV	B	