

REV.	DESCRIPTION	DATE	APPROVED
C	Engineering Update w/o Changes	02/20/04	M. C.
D	Removed Material Code	05/22/16	J. C.

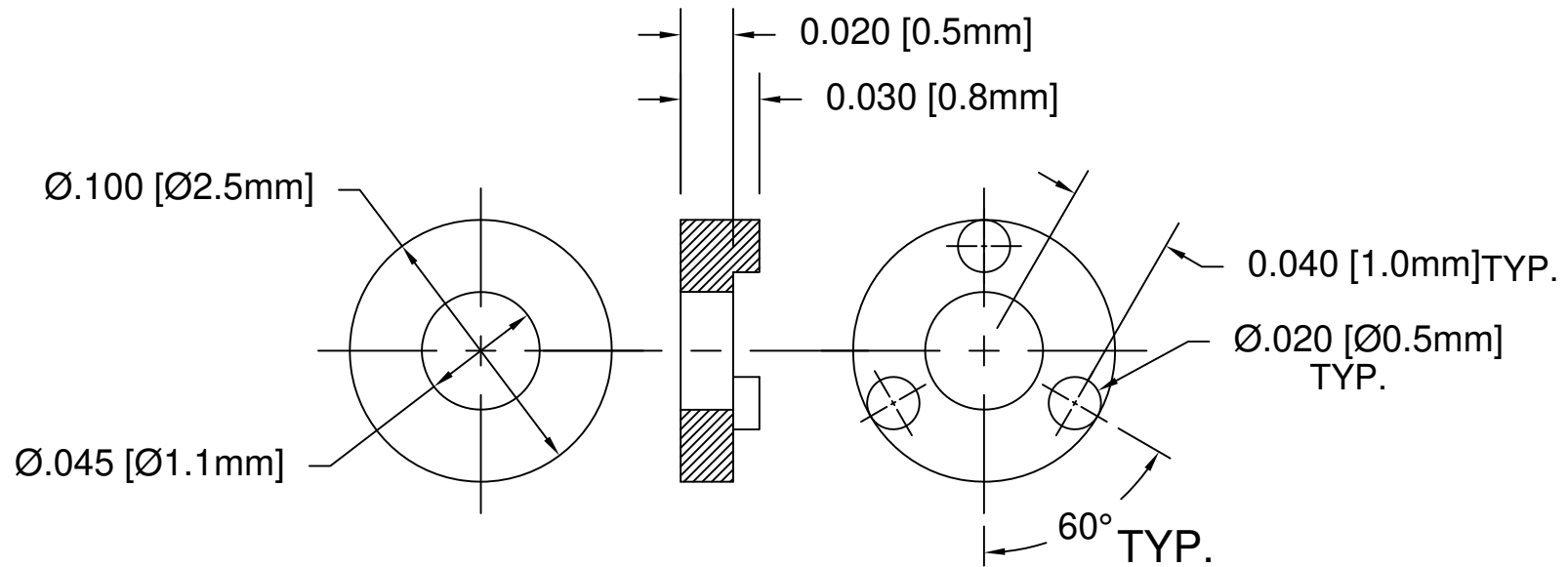

2. MATERIAL: NYLON 6/6, 94V-2, WHITE.

1. GENERAL SPECIFICATIONS: BIVAR MOLDED COMPONENT SPECIFICATION BV00-E101.

STANDARD TOLERANCE (UNLESS OTHERWISE SPECIFIED)		BIVAR®	
DECIMALS	ANGULAR	4 THOMAS, IRVINE, CA. 92618	
.X ±.1	X° ±1°	TEL: (949) 951-8808 FAX: (949) 951-3974	
.XX ±.01		TITLE: PERM-O-PAD	
.XXX ±.005		PART NO: 413-030	
DESIGNED: S. Irving	DATE: 05/12/98	REVISION: D	
CHECKED: D. Green	DATE: 02/20/04	CAGE CODE : 32559	SHEET # 1 OF 1
CAD GENERATED DOCUMENT, DO NOT MEASURE DRAWING.			