

## Dual-Channel Voltage Detector

### Features

- Two Independent Voltage Detectors in One Package
- Highly Accurate:  $\pm 2\%$
- Low Power Consumption: 2.0  $\mu\text{A}$ , typical
- Channel 1 Detect Voltage: 3.0V, 4.5V
- Channel 2 Detect Voltage: 2.7V
- Operating Voltage: 1.5V to 10.0V
- Output Configuration: N-Channel Open-Drain
- Space-Saving 5-Pin SOT-23 Package

### Typical Applications

- Battery Life Monitors and Recharge Voltage Monitors
- Memory Battery Backup Circuitry
- Power-On Reset Circuits
- Power Failure Detection
- Delay Circuitry

### Package Type

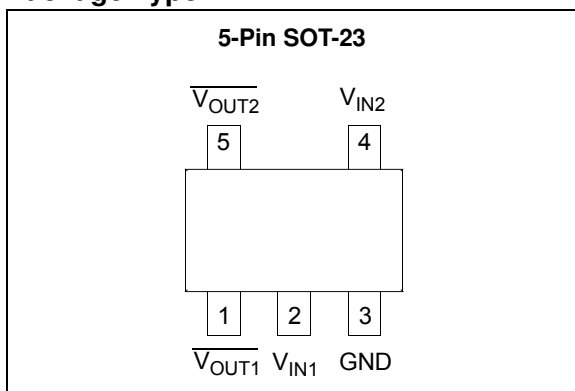

### Description

The TC52 consists of two independent low-power voltage detectors in a space-saving 5-pin SOT-23 package. Typical supply current consumption is only 2  $\mu\text{A}$  at an input voltage of 2V. The voltage detection threshold settings are factory-programmed and guaranteed to  $\pm 2\%$  accuracy. The TC52 is available with open drain (NMOS) configurations. Small-size, high-precision, low-supply current, and low installed cost makes the TC52 the ideal voltage detector for a wide variety of voltage monitoring applications.

### Functional Block Diagram

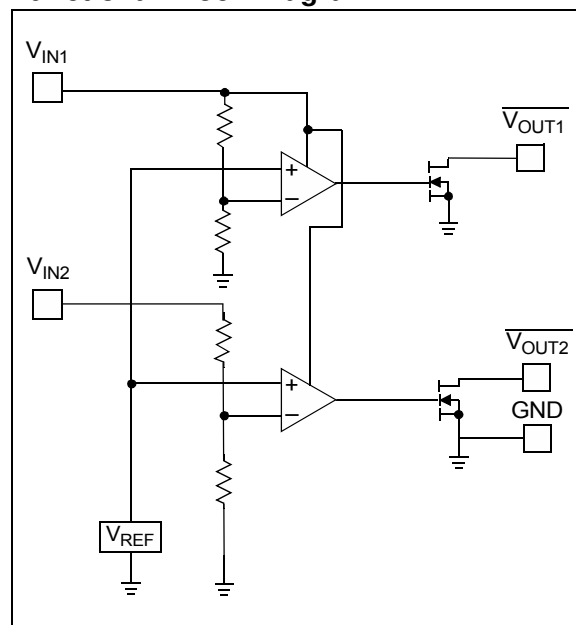

# TC52

## 1.0 ELECTRICAL CHARACTERISTICS

### Absolute Maximum Ratings\*

Input Voltage .....	+12V
Output Current .....	50 mA
Output Voltage.....	$V_{IN} + 0.3V$ to $V_{SS} - 0.3V$
Power Dissipation	
5-Pin SOT-23 .....	100 mW
Operating Temperature Range.....	-40°C to +85°C
Storage Temperature Range .....	-40°C to +125°C

† **Notice:** Stresses above those listed under "Absolute Maximum Ratings" may cause permanent damage to the device. These are stress ratings only and functional operation of the device at these or any other conditions above those indicated in the operation sections of the specifications is not implied. Exposure to Absolute Maximum Rating conditions for extended periods may affect device reliability.

### DC ELECTRICAL CHARACTERISTICS

Electrical Specifications: $T_A = 25^\circ\text{C}$ , unless otherwise specified. Note 1.						
Parameter	Sym.	Min.	Typ.	Max.	Units	Conditions
Operating Voltage	$V_{IN}$	1.5	—	10.0	V	$V_{DF}(T) = 1.5$ to $5.0V$
Supply Current	$I_{SS}$	—	1.35	3.90	$\mu\text{A}$	$V_{IN1} = 1.5V$
		—	1.50	4.50		$V_{IN1} = 2.0V$
		—	1.95	5.10		$V_{IN1} = 3.0V$
		—	2.40	5.70		$V_{IN1} = 4.0V$
		—	3.00	6.30		$V_{IN1} = 5.0V$
Input Current $V_{IN2}$	$I_{IN2}$	—	0.45	1.30	$\mu\text{A}$	$V_{IN1} = 1.5V$
		—	0.50	1.50		$V_{IN1} = 2.0V$
		—	0.65	1.70		$V_{IN1} = 3.0V$
		—	0.80	1.90		$V_{IN1} = 4.0V$
		—	1.00	2.10		$V_{IN1} = 5.0V$
Channel 1 Detect Voltage	$V_{DET1^-}$	$V_{T1} \times 0.98$	$V_{T1} \pm 0.5\%$	$V_{T1} \times 1.02$	V	Note 2
Channel 2 Detect Voltage	$V_{DET2^-}$	$V_{T2} \times 0.98$	$V_{T2} \pm 0.5\%$	$V_{T2} \times 1.02$	V	Note 2
Hysteresis Range 1	$V_{HYS1}$	$V_{DET1^-} \times 0.02$	$V_{DET1^-} \times 0.05$	$V_{DET1^-} \times 0.08$	V	
Hysteresis Range 2	$V_{HYS2}$	$V_{DET2^-} \times 0.02$	$V_{DET2^-} \times 0.05$	$V_{DET2^-} \times 0.08$	V	
Output Current	$I_{OUT}$	0.3	2.2	—	mA	$V_{OL} = 0.5V, V_{IN1} = 1.0V$
		3.0	7.7	—		$V_{OL} = 0.5V, V_{IN1} = 2.0V$
		5.0	10.1	—		$V_{OL} = 0.5V, V_{IN1} = 3.0V$
		6.0	11.5	—		$V_{OL} = 0.5V, V_{IN1} = 4.0V$
		7.0	13.0	—		$V_{OL} = 0.5V, V_{IN1} = 5.0V$
Temperature Characteristics	$\Delta V_{DET^-} / (\Delta T_{OPR} V_{DET^-})$	—	$\pm 100$	—	ppm/°C	$-40^\circ\text{C} \leq T_{OPR} \leq 85^\circ\text{C}$
Detection Time	$t_{DLY}$	—	—	0.2	msec	Time from $V_{IN} = V_{DET^-}$ to $V_{OUT} = V_{OL}$

**Note 1:** Additional resistance between the  $V_{IN1}$  pin and the supply voltage may alter the electrical characteristics.

**2:**  $V_{T1}, V_{T2}$  are the factory-programmed voltage detection thresholds.

## 2.0 PIN DESCRIPTIONS

The descriptions of the pins are listed in [Table 2-1](#).

**TABLE 2-1: PIN FUNCTION TABLE**

Pin No. (5-Pin SOT-23)	Symbol	Description
1	$V_{OUT1}$	Detector #1 output
2	$V_{IN}$	Supply voltage input, detect voltage 1
3	GND	Ground terminal
4	$V_{IN2}$	Detect voltage 2
5	$V_{OUT2}$	Detector #2 output

## 3.0 DETAILED DESCRIPTION

In normal steady-state operation and for either channel, when  $V_{IN} > V_{DET^-}$ , the output is high, see [Figure 3-1](#). (In the case of the TC52N, this is an open-drain condition.) If and when the input falls below  $V_{DET^-}$ , the output pulls down (Logic 0) to  $V_{SS}$ . Generally,  $V_{OUT}$  can pull down to within 0.5V of  $V_{SS}$  at rated output current and input voltages. (Also see [Section 1.0, Electrical Characteristics](#)).

The output,  $V_{OUT}$ , stays valid until the input voltage falls below the minimum operating voltage,  $V_{INMIN}$ , of 0.7V. Below this minimum operating voltage, the output is undefined. During power-up or anytime  $V_{IN}$  has fallen below  $V_{INMIN}$ ,  $V_{OUT}$  will remain undefined until  $V_{IN}$  rises above  $V_{INMIN}$ , at which time the output becomes valid.  $V_{OUT}$  is maintained in its active low state while  $V_{INMIN} < V_{IN} < V_{DET^+}$ . ( $V_{DET^+} = V_{DET^-} + V_{HYST}$ ). If and when the input rises above  $V_{DET^+}$ , the output will assume its inactive state (open-drain for TC52N).

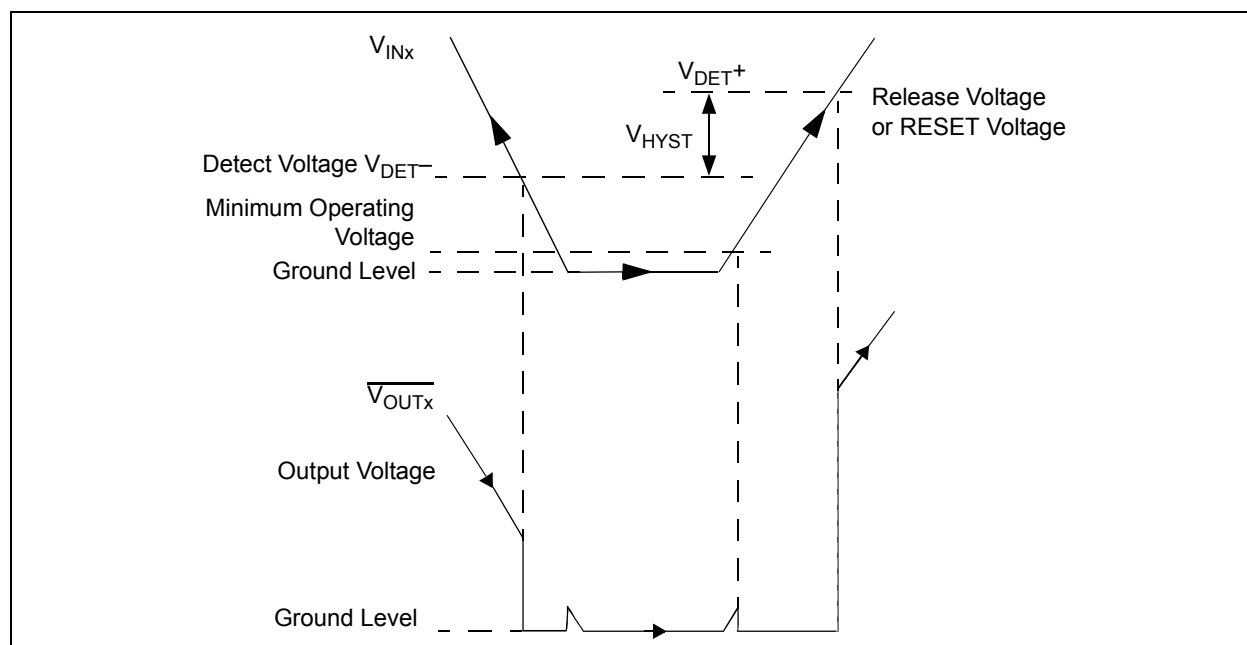

**FIGURE 3-1:** Timing Diagram.

## 4.0 APPLICATION INFORMATION

Pin 2 ( $V_{IN1}$ ) acts as both the input to Voltage Detector #1 and the power supply input for the chip. As such, always assign  $V_{IN1}$  to monitor voltages between 1.5V and 10V. Failure to do this will result in unreliable detector operation due to an out-of-tolerance supply voltage. In high-noise environments, it may be necessary to install a small input bypass capacitor (0.01  $\mu$ F to 0.1  $\mu$ F) from  $V_{IN1}$  to ground to minimize on-chip power supply noise.

## 5.0 PACKAGING INFORMATION

### 5.1 Package Marking Information

5-Lead SOT-23

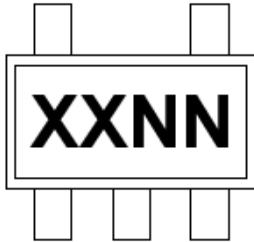

Standard Markings for SOT-23	
Part Number	Code
TC52N3027ECTTR	<u>N</u> 0C#
TC52N4527ECTTR	<u>N</u> 0P#

Example

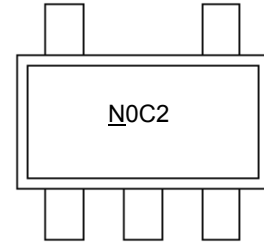

#### N-channel Indication and Integer Part of Output Voltage

Symbol	Output
<u>N</u>	Nch

#### Registration Serial Number

Symbol	Detected Voltage 1	Detected Voltage 2
0C	3.0	2.7
0P	4.5	2.7

<b>Legend:</b>	XX...X	Customer-specific information
	Y	Year code (last digit of calendar year)
	YY	Year code (last 2 digits of calendar year)
	WW	Week code (week of January 1 is week '01')
	NNN	Alphanumeric traceability code
	(e3)	Pb-free JEDEC designator for Matte Tin (Sn)
	*	This package is Pb-free. The Pb-free JEDEC designator (e3) can be found on the outer packaging for this package.

**Note:** In the event the full Microchip part number cannot be marked on one line, it will be carried over to the next line, thus limiting the number of available characters for customer-specific information.

## 5-Lead Plastic Small Outline Transistor (CT) [SOT-23]

**Note:** For the most current package drawings, please see the Microchip Packaging Specification located at <http://www.microchip.com/packaging>

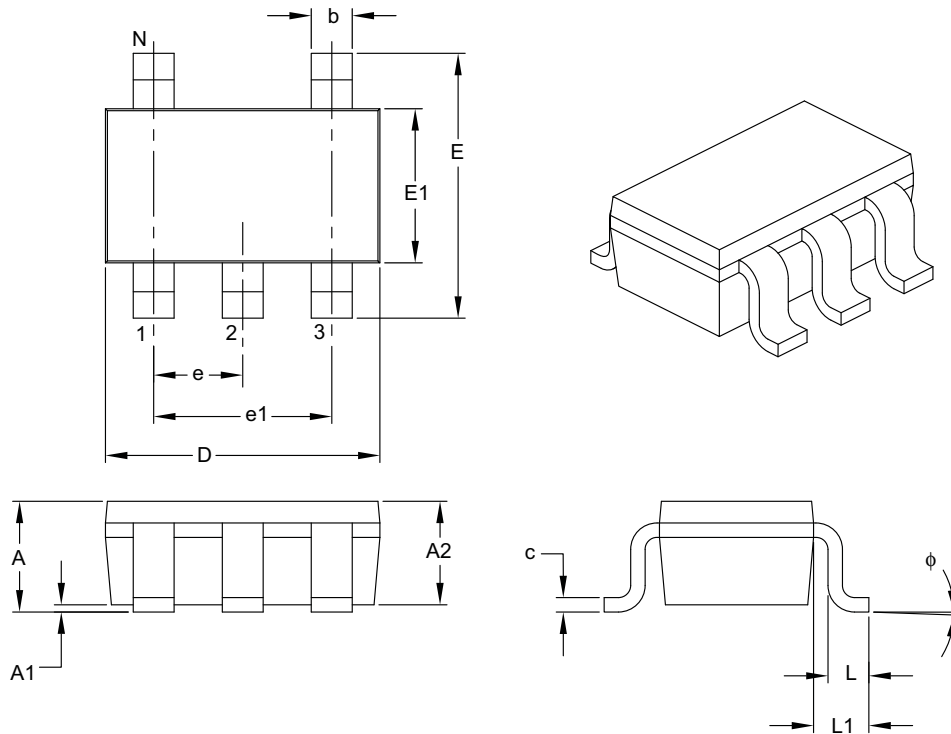

Dimension Limits	Units	MILLIMETERS		
		MIN	NOM	MAX
Number of Pins	N	5		
Lead Pitch	e	0.95 BSC		
Outside Lead Pitch	e1	1.90 BSC		
Overall Height	A	0.90	–	1.45
Molded Package Thickness	A2	0.89	–	1.30
Standoff	A1	0.00	–	0.15
Overall Width	E	2.20	–	3.20
Molded Package Width	E1	1.30	–	1.80
Overall Length	D	2.70	–	3.10
Foot Length	L	0.10	–	0.60
Footprint	L1	0.35	–	0.80
Foot Angle	$\phi$	0°	–	30°
Lead Thickness	c	0.08	–	0.26
Lead Width	b	0.20	–	0.51

**Notes:**

- Dimensions D and E1 do not include mold flash or protrusions. Mold flash or protrusions shall not exceed 0.127 mm per side.
- Dimensioning and tolerancing per ASME Y14.5M.  
BSC: Basic Dimension. Theoretically exact value shown without tolerances.

Microchip Technology Drawing C04-091B

## 5-Lead Plastic Small Outline Transistor (CT) [SOT-23]

**Note:** For the most current package drawings, please see the Microchip Packaging Specification located at <http://www.microchip.com/packaging>

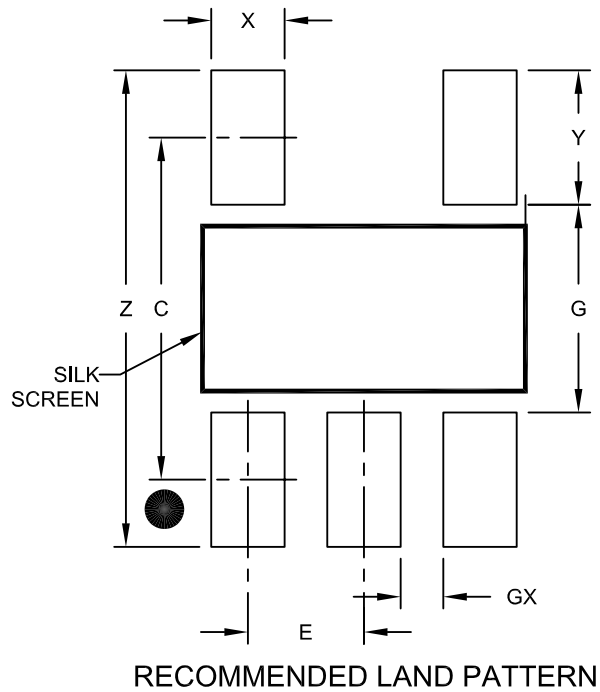

Dimension Limits	Units	MILLIMETERS		
		MIN	NOM	MAX
Contact Pitch	E	0.95 BSC		
Contact Pad Spacing	C		2.80	
Contact Pad Width (X5)	X			0.60
Contact Pad Length (X5)	Y			1.10
Distance Between Pads	G	1.70		
Distance Between Pads	GX	0.35		
Overall Width	Z			3.90

**Notes:**

1. Dimensioning and tolerancing per ASME Y14.5M

BSC: Basic Dimension. Theoretically exact value shown without tolerances.

Microchip Technology Drawing No. C04-2091A

# TC52

---

NOTES:



## **APPENDIX A: REVISION HISTORY**

### **Revision E (February 2015)**

- Updated device status to Obsolete.

### **Revision D (August 2013)**

The following is the list of modifications:

1. Updated the detect voltage values in "Features".
2. Updated the "Package Type" drawing.
3. Updated Section 5.0, "Packaging Information" with the latest package specification drawings.
4. Updated the "Product Identification System" section.

### **Revision C (December 2012)**

- Added a note to each package outline drawing.

### **Revision B (May 2002)**

- Undocumented changes.

### **Revision A (March 2001)**

- Original Release of this Document.

## PRODUCT IDENTIFICATION SYSTEM

To order or obtain information, e.g., on pricing or delivery, refer to the factory or the listed sales office.

<b>PART NO.</b>	<b>X</b>	<b>XX</b>	<b>XX</b>	<b>-X</b>	<b>XX</b>	<b>XX</b>
<b>Device</b>	<b>Output Configuration</b>	<b>Detected Voltage 1</b>	<b>Detected Voltage 2</b>	<b>Temperature Range</b>	<b>Package</b>	<b>Tape and Reel</b>
<p><b>Examples:</b></p> <p>a) TC52N3027ECTTR: 3.0V and 2.7V Dual Channel Voltage Detector, 5LD SOT-23 package, Tape and Reel</p> <p>b) TC52N4527ECTTR: 4.5V and 2.7V Dual Channel Voltage Detector, 5LD SOT-23 package, Tape and Reel</p>						
<p><b>Device:</b> TC52N3027ECTTR: 3.0V and 2.7V Dual Channel Voltage Detector (Tape and Reel)            TC52N4527ECTTR: 4.5V and 2.7V Dual Channel Voltage Detector (Tape and Reel)</p> <p><b>Output Configuration:</b> N = Open Drain</p> <p><b>Detected Voltage 1:</b> 30 = 3.0V 45 = 4.5V</p> <p><b>Detected Voltage 2:</b> 27 = 2.7V</p> <p><b>Temperature Range:</b> E = -40°C to +125°C</p> <p><b>Package:</b> CT = Plastic Small Outline Transistor (CT), 5-Lead</p>						

---

---

**Note the following details of the code protection feature on Microchip devices:**

- Microchip products meet the specification contained in their particular Microchip Data Sheet.
- Microchip believes that its family of products is one of the most secure families of its kind on the market today, when used in the intended manner and under normal conditions.
- There are dishonest and possibly illegal methods used to breach the code protection feature. All of these methods, to our knowledge, require using the Microchip products in a manner outside the operating specifications contained in Microchip's Data Sheets. Most likely, the person doing so is engaged in theft of intellectual property.
- Microchip is willing to work with the customer who is concerned about the integrity of their code.
- Neither Microchip nor any other semiconductor manufacturer can guarantee the security of their code. Code protection does not mean that we are guaranteeing the product as “unbreakable.”

Code protection is constantly evolving. We at Microchip are committed to continuously improving the code protection features of our products. Attempts to break Microchip's code protection feature may be a violation of the Digital Millennium Copyright Act. If such acts allow unauthorized access to your software or other copyrighted work, you may have a right to sue for relief under that Act.

---

Information contained in this publication regarding device applications and the like is provided only for your convenience and may be superseded by updates. It is your responsibility to ensure that your application meets with your specifications. MICROCHIP MAKES NO REPRESENTATIONS OR WARRANTIES OF ANY KIND WHETHER EXPRESS OR IMPLIED, WRITTEN OR ORAL, STATUTORY OR OTHERWISE, RELATED TO THE INFORMATION, INCLUDING BUT NOT LIMITED TO ITS CONDITION, QUALITY, PERFORMANCE, MERCHANTABILITY OR FITNESS FOR PURPOSE. Microchip disclaims all liability arising from this information and its use. Use of Microchip devices in life support and/or safety applications is entirely at the buyer's risk, and the buyer agrees to defend, indemnify and hold harmless Microchip from any and all damages, claims, suits, or expenses resulting from such use. No licenses are conveyed, implicitly or otherwise, under any Microchip intellectual property rights.

#### **Trademarks**

The Microchip name and logo, the Microchip logo, dsPIC, FlashFlex, flexPWR, JukeBlox, KEELOQ, KEELOQ logo, Kleer, LANCheck, MediaLB, MOST, MOST logo, MPLAB, OptoLyzer, PIC, PICSTART, PIC<sup>32</sup> logo, RightTouch, SpyNIC, SST, SST Logo, SuperFlash and UNI/O are registered trademarks of Microchip Technology Incorporated in the U.S.A. and other countries.

The Embedded Control Solutions Company and mTouch are registered trademarks of Microchip Technology Incorporated in the U.S.A.

Analog-for-the-Digital Age, BodyCom, chipKIT, chipKIT logo, CodeGuard, dsPICDEM, dsPICDEM.net, ECAN, In-Circuit Serial Programming, ICSP, Inter-Chip Connectivity, KleerNet, KleerNet logo, MiWi, MPASM, MPF, MPLAB Certified logo, MPLIB, MPLINK, MultiTRAK, NetDetach, Omniscient Code Generation, PICDEM, PICDEM.net, PICkit, PICtail, RightTouch logo, REAL ICE, SQI, Serial Quad I/O, Total Endurance, TSHARC, USBCheck, VariSense, ViewSpan, WiperLock, Wireless DNA, and ZENA are trademarks of Microchip Technology Incorporated in the U.S.A. and other countries.

SQTP is a service mark of Microchip Technology Incorporated in the U.S.A.

Silicon Storage Technology is a registered trademark of Microchip Technology Inc. in other countries.

GestIC is a registered trademarks of Microchip Technology Germany II GmbH & Co. KG, a subsidiary of Microchip Technology Inc., in other countries.

All other trademarks mentioned herein are property of their respective companies.

© 2001-2015, Microchip Technology Incorporated, Printed in the U.S.A., All Rights Reserved.

ISBN: 978-1-63277-069-1

**QUALITY MANAGEMENT SYSTEM**  
**CERTIFIED BY DNV**  
**== ISO/TS 16949 ==**

*Microchip received ISO/TS-16949:2009 certification for its worldwide headquarters, design and wafer fabrication facilities in Chandler and Tempe, Arizona; Gresham, Oregon and design centers in California and India. The Company's quality system processes and procedures are for its PIC® MCUs and dsPIC® DSCs, KEELOQ® code hopping devices, Serial EEPROMs, microperipherals, nonvolatile memory and analog products. In addition, Microchip's quality system for the design and manufacture of development systems is ISO 9001:2000 certified.*



# MICROCHIP

## Worldwide Sales and Service

### AMERICAS

**Corporate Office**  
2355 West Chandler Blvd.  
Chandler, AZ 85224-6199  
Tel: 480-792-7200  
Fax: 480-792-7277  
Technical Support:  
<http://www.microchip.com/support>  
Web Address:  
[www.microchip.com](http://www.microchip.com)

**Atlanta**  
Duluth, GA  
Tel: 678-957-9614  
Fax: 678-957-1455

**Austin, TX**  
Tel: 512-257-3370

**Boston**  
Westborough, MA  
Tel: 774-760-0087  
Fax: 774-760-0088

**Chicago**  
Itasca, IL  
Tel: 630-285-0071  
Fax: 630-285-0075

**Cleveland**  
Independence, OH  
Tel: 216-447-0464  
Fax: 216-447-0643

**Dallas**  
Addison, TX  
Tel: 972-818-7423  
Fax: 972-818-2924

**Detroit**  
Novi, MI  
Tel: 248-848-4000

**Houston, TX**  
Tel: 281-894-5983

**Indianapolis**  
Noblesville, IN  
Tel: 317-773-8323  
Fax: 317-773-5453

**Los Angeles**  
Mission Viejo, CA  
Tel: 949-462-9523  
Fax: 949-462-9608

**New York, NY**  
Tel: 631-435-6000

**San Jose, CA**  
Tel: 408-735-9110

**Canada - Toronto**  
Tel: 905-673-0699  
Fax: 905-673-6509

### ASIA/PACIFIC

**Asia Pacific Office**  
Suites 3707-14, 37th Floor  
Tower 6, The Gateway  
Harbour City, Kowloon  
Hong Kong  
Tel: 852-2943-5100  
Fax: 852-2401-3431

**Australia - Sydney**  
Tel: 61-2-9868-6733  
Fax: 61-2-9868-6755

**China - Beijing**  
Tel: 86-10-8569-7000  
Fax: 86-10-8528-2104

**China - Chengdu**  
Tel: 86-28-8665-5511  
Fax: 86-28-8665-7889

**China - Chongqing**  
Tel: 86-23-8980-9588  
Fax: 86-23-8980-9500

**China - Dongguan**  
Tel: 86-769-8702-9880

**China - Hangzhou**  
Tel: 86-571-8792-8115  
Fax: 86-571-8792-8116

**China - Hong Kong SAR**  
Tel: 852-2943-5100  
Fax: 852-2401-3431

**China - Nanjing**  
Tel: 86-25-8473-2460  
Fax: 86-25-8473-2470

**China - Qingdao**  
Tel: 86-532-8502-7355  
Fax: 86-532-8502-7205

**China - Shanghai**  
Tel: 86-21-5407-5533  
Fax: 86-21-5407-5066

**China - Shenyang**  
Tel: 86-24-2334-2829  
Fax: 86-24-2334-2393

**China - Shenzhen**  
Tel: 86-755-8864-2200  
Fax: 86-755-8203-1760

**China - Wuhan**  
Tel: 86-27-5980-5300  
Fax: 86-27-5980-5118

**China - Xian**  
Tel: 86-29-8833-7252  
Fax: 86-29-8833-7256

### ASIA/PACIFIC

**China - Xiamen**  
Tel: 86-592-2388138  
Fax: 86-592-2388130

**China - Zhuhai**  
Tel: 86-756-3210040  
Fax: 86-756-3210049

**India - Bangalore**  
Tel: 91-80-3090-4444  
Fax: 91-80-3090-4123

**India - New Delhi**  
Tel: 91-11-4160-8631  
Fax: 91-11-4160-8632

**India - Pune**  
Tel: 91-20-3019-1500

**Japan - Osaka**  
Tel: 81-6-6152-7160  
Fax: 81-6-6152-9310

**Japan - Tokyo**  
Tel: 81-3-6880-3770  
Fax: 81-3-6880-3771

**Korea - Daegu**  
Tel: 82-53-744-4301  
Fax: 82-53-744-4302

**Korea - Seoul**  
Tel: 82-2-554-7200  
Fax: 82-2-558-5932 or  
82-2-558-5934

**Malaysia - Kuala Lumpur**  
Tel: 60-3-6201-9857  
Fax: 60-3-6201-9859

**Malaysia - Penang**  
Tel: 60-4-227-8870  
Fax: 60-4-227-4068

**Philippines - Manila**  
Tel: 63-2-634-9065  
Fax: 63-2-634-9069

**Singapore**  
Tel: 65-6334-8870  
Fax: 65-6334-8850

**Taiwan - Hsin Chu**  
Tel: 886-3-5778-366  
Fax: 886-3-5770-955

**Taiwan - Kaohsiung**  
Tel: 886-7-213-7828

**Taiwan - Taipei**  
Tel: 886-2-2508-8600  
Fax: 886-2-2508-0102

**Thailand - Bangkok**  
Tel: 66-2-694-1351  
Fax: 66-2-694-1350

### EUROPE

**Austria - Wels**  
Tel: 43-7242-2244-39  
Fax: 43-7242-2244-393

**Denmark - Copenhagen**  
Tel: 45-4450-2828  
Fax: 45-4485-2829

**France - Paris**  
Tel: 33-1-69-53-63-20  
Fax: 33-1-69-30-90-79

**Germany - Dusseldorf**  
Tel: 49-2129-3766400

**Germany - Munich**  
Tel: 49-89-627-144-0  
Fax: 49-89-627-144-44

**Germany - Pforzheim**  
Tel: 49-7231-424750

**Italy - Milan**  
Tel: 39-0331-742611  
Fax: 39-0331-466781

**Italy - Venice**  
Tel: 39-049-7625286

**Netherlands - Drunen**  
Tel: 31-416-690399  
Fax: 31-416-690340

**Poland - Warsaw**  
Tel: 48-22-3325737

**Spain - Madrid**  
Tel: 34-91-708-08-90  
Fax: 34-91-708-08-91

**Sweden - Stockholm**  
Tel: 46-8-5090-4654

**UK - Wokingham**  
Tel: 44-118-921-5800  
Fax: 44-118-921-5820

01/27/15