

SECTION A-A

spec ref	-	dr	Eric Jiang	2013/01/14	projection	MM	size	A2	scale	1:1
tolerance std	ISO 406 ISO 1101	eng	Sunny2 Liu	2016/05/05			ecn no	ELX-DG-24036-1	rel level	Released
TOLERANCES UNLESS OTHERWISE SPECIFIED		chr	Terris Liu	2016/05/20						
		appr	Pai-Ming Zheng	2016/05/24						
surface	linear	0.X	±0.5	Amphenol FCI	product family		VERT RECT (24P OMIT 8P) HIGH POWER CARD EDGE	dwg no 10124023	rev B	
		0.XX	±0.25		cat. no.					Product - Customer Drw
	angular	0°	±2°		sheet 1 of 4					

CONTACT TYPE	TOP LAYER DESCRIPTION	TABLE 1 (HPCE / SOLDER TAILS) PLATED THROUGH-HOLE REQUIREMENTS				
		DRILLED HOLE DIAMETER	COPPER THICKNESS	TIN-LEAD THICKNESS	TIN THICKNESS	FINISHED HOLE DIAMETER
POWER & SIGNAL	TIN-LEAD	1.10-1.16 (1.15 DRILL)	0.025 - 0.050	0.005 - 0.015	--	0.94 - 1.10
	IMMERSION TIN	1.10-1.16 (1.15 DRILL)	0.025 - 0.050	--	0.9 - 1.5um	0.94 - 1.10
	COPPER (SEE NOTE 8)	1.10-1.16 (1.15 DRILL)	0.025 - 0.050	--	--	0.94 - 1.10

CONTACT TYPE	TOP LAYER DESCRIPTION	TABLE 2 (HPCE / PRESS-FIT TAILS) PLATED THROUGH-HOLE REQUIREMENTS				
		DRILLED HOLE DIAMETER	COPPER THICKNESS	TIN-LEAD THICKNESS	TIN THICKNESS	FINISHED HOLE DIAMETER
POWER & SIGNAL	TIN-LEAD	0.81-0.86 (0.85 DRILL)	0.025 - 0.050	0.005 - 0.015	--	0.65 - 0.80
	IMMERSION TIN	0.81-0.86 (0.85 DRILL)	0.025 - 0.050	--	0.9 - 1.5um	0.70 - 0.80
	COPPER (SEE NOTE 8)	0.81-0.86 (0.85 DRILL)	0.025 - 0.050	--	--	0.70 - 0.80

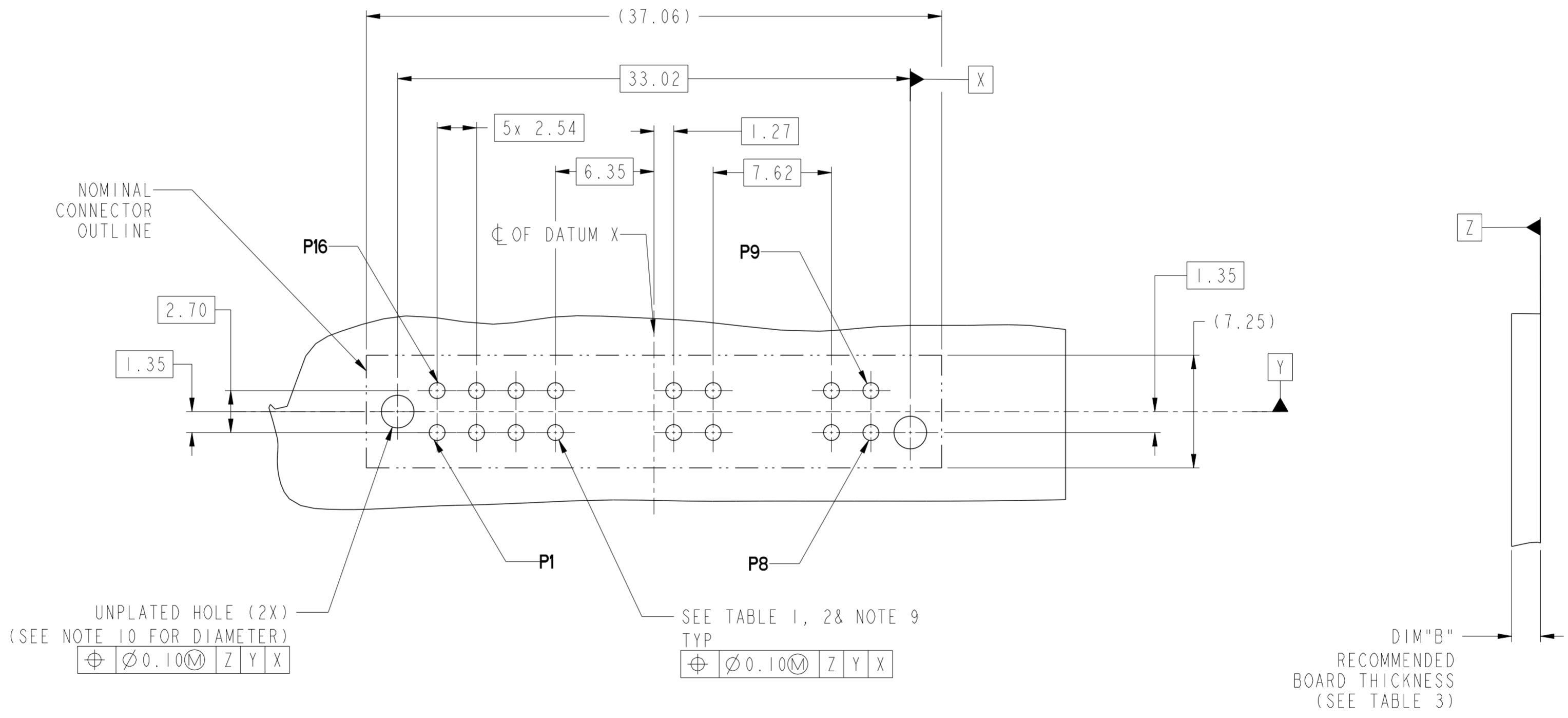

spec ref	-	dr	Eric Jiang	2013/01/14	projection	MM	size	A2	scale	1:1
tolerance std	ISO 406 ISO 1101	eng	Sunny2 Liu	2016/05/05			ecn no	ELX-DG-24036-1	rel level	Released
TOLERANCES UNLESS OTHERWISE SPECIFIED		chr	Terris Liu	2016/05/20						
		appr	Pai-Ming Zheng	2016/05/24						
surface	linear	0.X	±0.5	Amphenol FCI	product family		VERT RECT (24P OMIT 8P) HIGH POWER CARD EDGE	cat. no.	Product - Customer Drw	sheet 2 of 4
		0.XX	±0.25		title	10124023				
	angular	0°	±2°		VERT RECT (24P OMIT 8P) HIGH POWER CARD EDGE	rev B				

Amphenol FCI

© 2016 AFCI

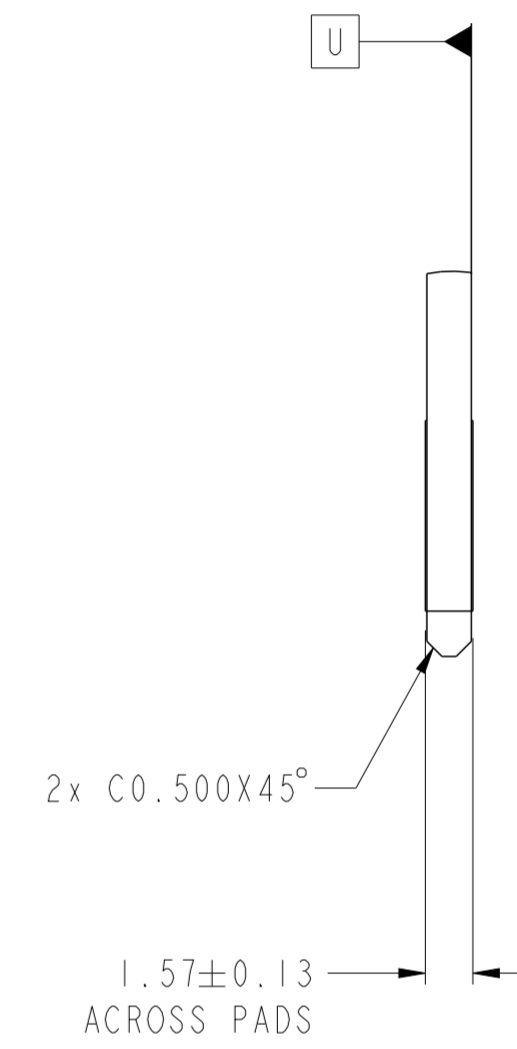
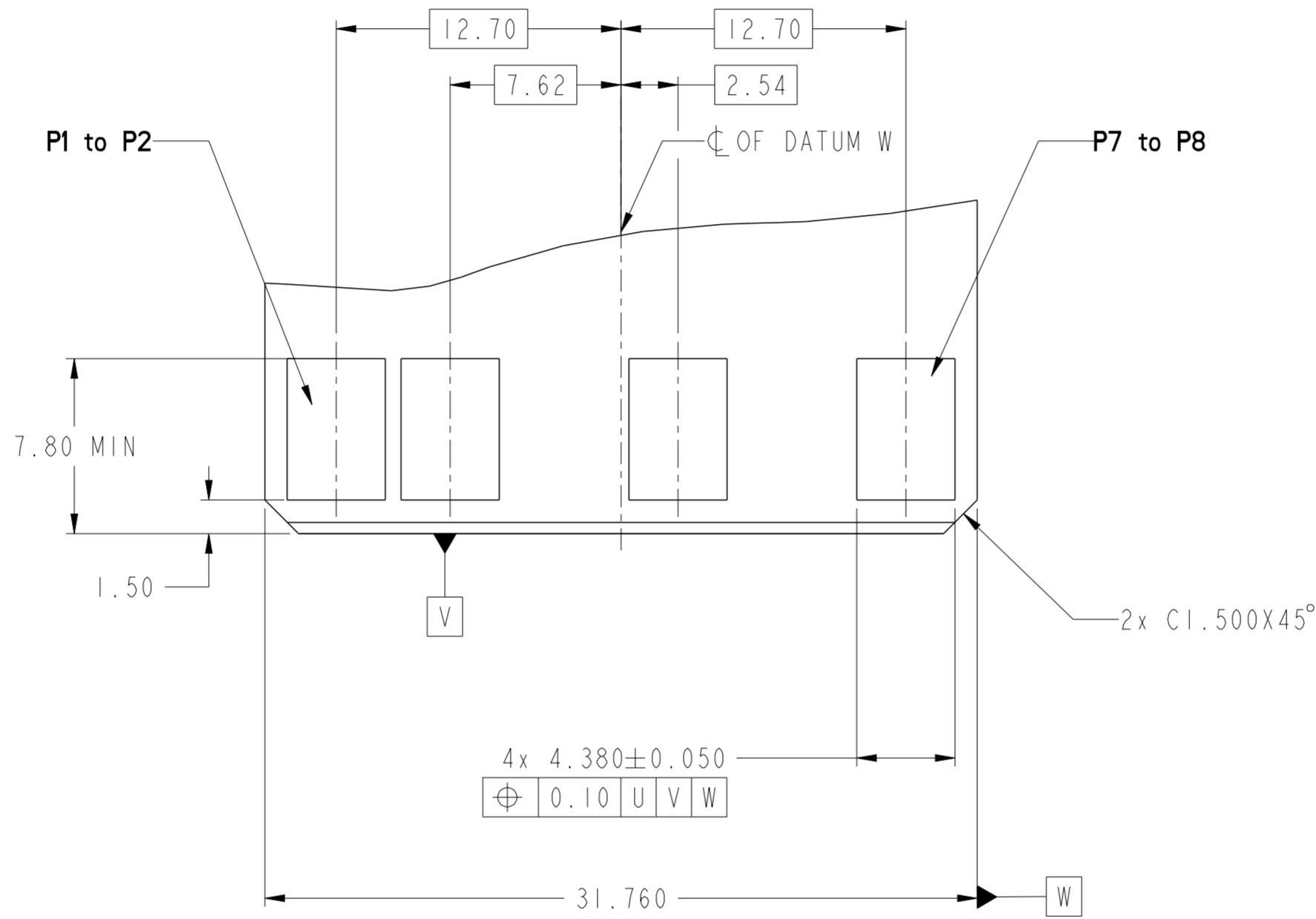

Amphenol
FCi

© 2016 AFci

spec ref	-	dr	Eric Jiang	2013/01/14	projection	MM	size	A2	scale	1:1
tolerance std	ISO 406 ISO 1101	eng	Sunny2 Liu	2016/05/05			ecn no	ELX-DG-24036-1	rel level	Released
TOLERANCES UNLESS OTHERWISE SPECIFIED		chr	Terris Liu	2016/05/20						
		appr	Pai-Ming Zheng	2016/05/24						
surface	ISO 1302	linear	0.X	±0.5			title VERT RECT (24P OMIT 8P) HIGH POWER CARD EDGE		dwg no 10124023	rev B
		angular	0°	±2°	cat. no.	Product - Customer Drw		sheet 3 of 4		

PDS: Rev :B

STATUS:Released

Printed: May 24, 2016

HPCE PART NUMBER (TABLE 3)

PART NUMBER	TAIL TYPE	ORIENTATION KEY	DIM "A" TYPICAL TAIL LENGTH	DIM "B" RECOMMENDED BOARD THICKNESS
10124023-001LF	SOLDER	NO	3.17 ±0.25	1.59 - 2.38
10124023-002LF	PRESS-FIT	NO	3.17 ±0.25	1.57 MIN

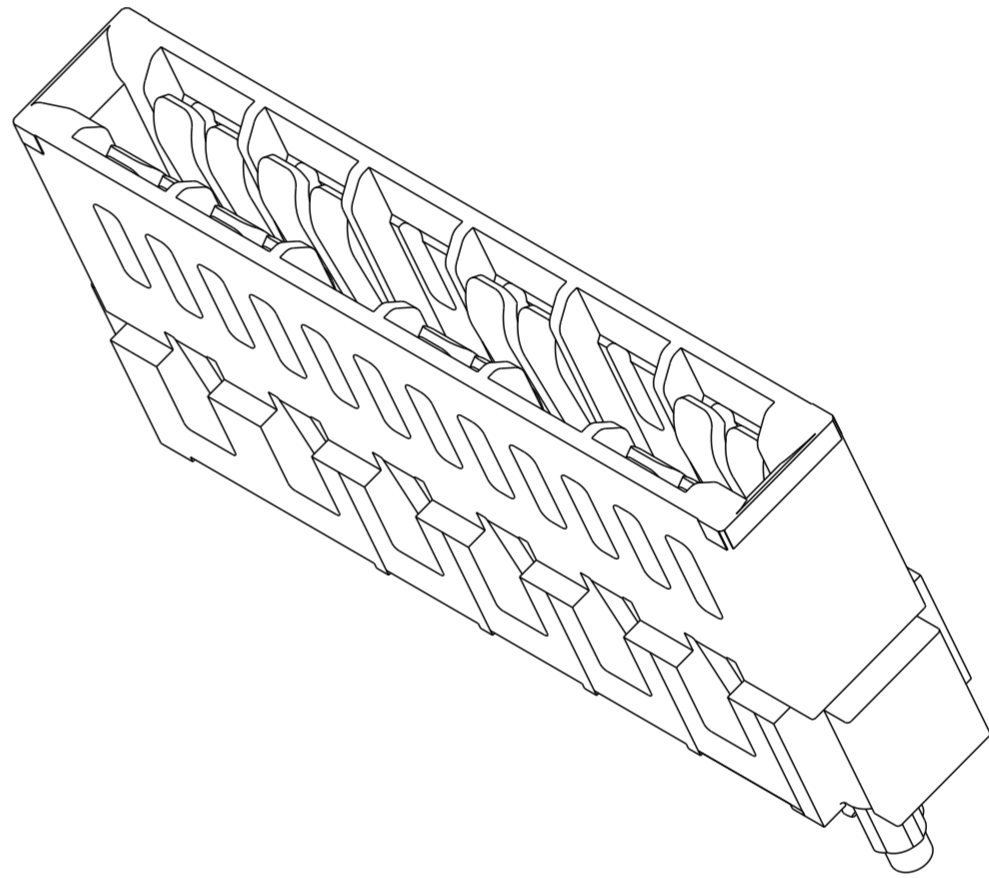

NOTES:

1. CONNECTOR MATERIALS:
 HOUSING: HIGH TEMPERATURE THERMAL PLASTIC, BLACK
 UL 94V-0 COMPLIANT
 CONTACTS: HIGH PERFORMANCE COPPER ALLOY.
2. CONTACT FINISH REF. GS-12-604 SECTION 5.2.
3. PRODUCT SPECIFICATION: GS-12-604.
4. APPLICATION SPECIFICATION: GS-20-128.
5. PRODUCT MARKING ON HOUSING IN AREA SHOWN MEETS AFCI SPECIFICATION: GS-24-007.
6. PACKAGING MEETS FCI SPECIFICATION GS-14-937.
7. HOUSING COMPONENT WILL WITHSTAND EXPOSURE TO 260°C PEAK TEMPERATURE FOR 60 SECONDS IN A CONVECTION, INFRA-RED, OR VAPOR PHASE REFLOW OVEN.
8. COPPER PLATING THICKNESS IN CENTER OF VIA-HOLE CAN BE NO MORE THAN 0.003 LESS THAN OTHER AREAS.
9. ALL HOLE SIZES ARE FINISHED HOLE SIZES.
10. MOUNTING HOLES ARE UNPLATED
 Ø 2.40 +/- 0.1 FOR PRESS-FIT TAILS
 Ø 2.18 +/- 0.03 FOR SOLDER TAILS
11. PRESS FIT APPLICATION TOOL DRAWING : 10119453.
12. A SYMBOL $\triangle B$ WILL BE NEXT TO ANY DIMENSION, VIEW, OR NOTE WHICH HAS BEEN MODIFIED WITH THE CURRENT DRAWING REVISION.

Amphenol FCI

© 2016 AFCI

spec ref	-	dr	Eric Jiang	2013/01/14	projection	MM	size	A2	scale	1:1
tolerance std	ISO 406 ISO 1101	eng	Sunny2 Liu	2016/05/05			ecn no	ELX-DG-24036-1		
TOLERANCES UNLESS OTHERWISE SPECIFIED		chr	Terris Liu	2016/05/20			rel level	Released		
surface	ISO 1302	appr	Pei-Ming Zheng	2016/05/24			product family	VERT RECT (24P OMIT 8P) HIGH POWER CARD EDGE		
		linear	0.X	±0.5	Amphenol FCI	title	10124023	rev	B	
			0.XX	±0.25		cat. no.	Product - Customer Drw		sheet 4 of 4	
		angular	0°	±2°						

PDS: Rev :B

STATUS:Released

Printed: May 24, 2016