

Enclosures can be Factory Modified (Milling, Drilling, Printing etc.)
Contact Factory mjm@hammondmfg.com for quotes
Solid models of this enclosure available in STEP or IGES.
(Part number and text placement/orientation on our products are subject to change, we do not recommend using them as a locating reference for modification purposes)

NOTE	
Enclosure made from FR ABS (UL 94-V0) plastic.	
Purchased assembly includes Top, Bottom, front plastic panel, Battery Door, battery spring clips (4 pcs), 9V adapter (1pcs) and 6Cover Screws. M3 Brass Inserts are Pre-Installed.	
Recommended Cover screw torque -- 2.5 lbf-in (30 cN-m)	

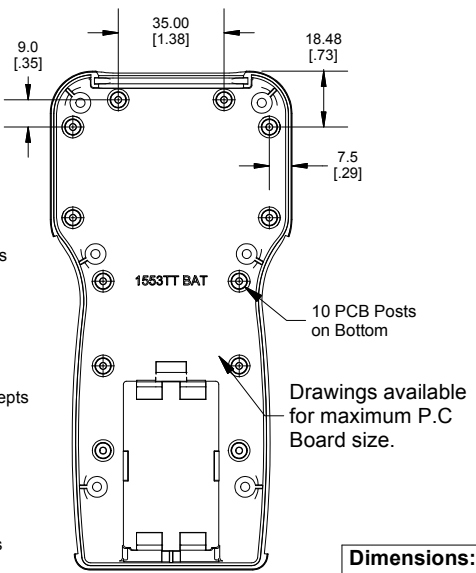
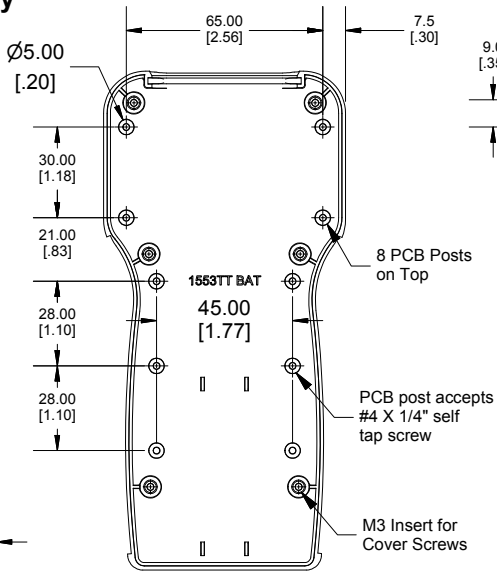
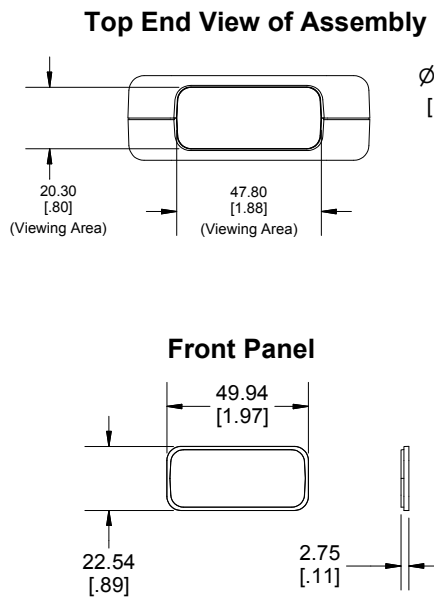

PART NUMBER	
1553TT Battery Enclosure	
Black Enclosure/Grey Over-mold	1553TTBKBAT
Grey Enclosure/Grey Over-mold	1553TTGYBAT
ACCESSORIES	
Cover screw (Pkg 100) [M3-0.5 X 18mm]	1594MS100 (silver) 1594MS100BK (Black)
P. C. Board Self Tapping Screw [#4 X 1/4" (6.4mm) Plated]	1593ATS50 (Pkg 50) 1593ATS100 (Pkg 100)
Belt or Pocket Clip	1599CLIP (Black) 1599CLIPGY (Grey)
9V Battery Kit	BS61
AA Battery Clip Kit (4 positive and 4 Negative)	1553HDR-BKIT

Dimensions:
mm
[inches]

HAMMOND MANUFACTURING
1553TTBAT
www.hammondmfg.com