

















**FineAdjust™ APPLICATOR**  
**Operation Manual**  
**Order No 63800-4900**









- Description
- Operation
- Maintenance

## Safety Warnings and Information

	<p><b>Read and understand</b> all of the instructions and safety information in this manual before operating or servicing this tool.</p> <p style="text-align: center;"><u>Keep this manual available when using this tool.</u></p> <p>Replacement manuals are available for download at no charge at <a href="http://www.molex.com">www.molex.com</a>.</p>
---	---

<b>SAFETY ALERT SYMBOL</b>	
<p>This symbol is used to call your attention to hazards or unsafe practices which could result in an injury or property damage. The signal word, defined below, indicates the severity of the hazard. The message after the signal word provides information for preventing or avoiding the hazard.</p>	
 <b>DANGER</b>	<p><b>DANGER:</b> Indicates an imminently hazardous situation which, if not avoided, could result in death or serious injury.</p>
 <b>WARNING</b>	<p><b>WARNING:</b> Indicates a potentially hazardous situation which, if not avoided, could result in death or serious injury.</p>
 <b>CAUTION</b>	<p><b>CAUTION:</b> Indicates a potentially hazardous situation which, if not avoided, may result in minor or moderate injury. <b>CAUTION</b> may also be used to alert against unsafe practices associated with events that could lead to personal injury.</p>

	<p> <b>WARNING</b></p> <p><b>Always</b> wear proper eye protection when Operating or servicing this equipment.</p> <p>Failure to wear eye protection could result in serious eye injury from flying debris.</p>		<p> <b>WARNING</b></p> <p><b>Heavy Object</b> To avoid muscle strain or back injury, use lifting aids and proper lifting techniques when removing or replacing.</p> <p>Failure to observe these precautions may result in injury or property damage.</p>
	<p> <b>WARNING</b></p> <p><b>Never</b> wear clothing or jewelry that is loose or That could potentially hang into the equipment and get caught.</p> <p>Failure to observe this warning could result in Severe Injury or death.</p>		<p> <b>WARNING</b></p> <p><b>Never</b> install or service this machine while connected to any electrical power source. Disconnect power by unplugging the press from its power source.</p> <p>Failure to observe this warning could result In severe injury or death.</p>
	<p> <b>WARNING</b></p> <p><b>Never</b> operate, service, install, or adjust this machine without proper instruction and without first reading and understanding the instructions in this manual and all applicable press and/or wire processing machine manuals.</p>		<p> <b>WARNING</b></p> <p><b>Always</b> hand cycle the applicator in the equipment to ensure the tooling is properly aligned.</p> <p>Failure to observe these precautions may result in Injury or property damage.</p>

	 <b>WARNING</b>	 <b>WARNING</b>
	<p><b>Never</b> use this press or wire processing machine without guards or safety devices that are intended to prevent hands from remaining in the die space.</p> <p>Failure to observe this warning could result in Severe injury or death.</p>	 <p><b>Do not use</b> compressed air to clean this equipment. The forces created by compressed air can force debris into the tool.</p> <p>Failure to observe these precautions may result in injury or property damage.</p>
	 <b>WARNING</b> <b>Always</b> wear proper ear protection when Operating or servicing this applicator.	
 <b>CAUTION</b> The Molex applicators are designed to operate in presses with standard shut heights of 135.80mm (5.346"). Installation in crimp presses with other than standard shut heights can cause severe tool breakage. It is advisable that before installation, a check of the shut height be performed. Molex will not be liable for any damages as a result of installation in a crimp press with nonstandard or improperly set shut height. Failure to observe these precautions may result in injury or property damage.		
 <b>CAUTION</b> <b>Never</b> perform any service or maintenance other than as described in this manual. <b>Never</b> modify, alter or misuse the equipment Molex crimp specifications are valid only when used with Molex terminals, applicators and tooling. Failure to observe this precaution may result in injury and property damage.		

**Tooling Technical Assistance**

Molex offers tooling technical assistance for customers who may need some guidance for tooling adjustments. This support can be obtained by calling either of the two numbers listed below and asking for the Molex Tooling Group.  
 Call Toll Free 1-800-786-6539 (US) 1-630-969-4550 (Global).

This assistance is limited to the operation and set-up of a customer's Molex Press. Questions with regard to Molex connector products or how to identify the proper tooling and/ or tooling documentation should be directed to your local Molex personnel or Customer Service Representative.

When calling for service on the press a copy of the *Tooling Manual* and Specific *Applicator Tooling Specification Sheet* should be present and a person that is familiar with the applicator should be present. Be sure the following information is supplied:

1. Customer name
2. Customer address
3. Person to contact such as (name, title, e-mail, and telephone number)
4. Applicator order number (Lease number also if applicable)
5. Serial number (Lease number also if applicable)
6. Molex Connector product order number
7. Urgency of request
8. Nature of problem

**Molex Application Tooling Group**  
 2200 Wellington Court  
 Lisle, IL 60532, USA  
 Tel: +1 (630) 969-4550  
 Fax: +1 (630) 505-0049

Visit our Web site at <http://www.molex.com>

## Table of Contents

### Contents

FineAdjust™ APPLICATOR .....	1
Order No 63800-4900.....	1
Safety Warnings and Information .....	2
<b>Table of Contents</b> .....	4
Section 1 .....	6
General Description .....	6
Principal Mechanical Parts of the FineAdjust Applicator .....	7
1.1 Description.....	8
1.2 Features .....	8
1.3 Technical Specification.....	8
1.4 Delivery Check .....	8
1.5 Tools.....	9
1.6 Specification Sheets .....	9
Section 2 .....	10
Set-Up and Operation.....	10
2.1 Shut Height.....	11
2.2 Set-Up .....	11
2.3 Adjustments.....	13
2.4 Crimp Tooling Installation and Removal .....	16
Section 3 .....	18
Maintenance .....	18
3.1 Cleaning .....	19
3.2 Lubrication .....	19
3.3 Spare Parts.....	20
3.4 Perishable Parts .....	20
3.5 Storage.....	21
Section 4 .....	22
Styles of FineAdjust .....	23
4.1 STYLE A-FineAdjust Applicator.....	24
4.1 STYLE A FineAdjust Applicator Assembly.....	26
4.1 STYLE A FineAdjust Applicator Assembly (Cont.).....	27
4.2 STYLE B-FineAdjust Applicator .....	28
4.2 STYLE B FineAdjust Applicator Assembly.....	30
4.2 STYLE B FineAdjust Applicator Assembly (Cont.).....	31
4.3 STYLE C-FineAdjust Applicator.....	32
4.3 STYLE C FineAdjust Applicator Assembly .....	34
4.3 STYLE C FineAdjust Applicator Assembly (Cont.) .....	35
4.4 Troubleshooting.....	36
Appendix A.....	38
Crimp Terminations .....	38
A.1 Conductor Brush and Terminal Position .....	39
A.2 Conductor Bell Mouth and Terminal Cutoff Tab.....	40
A.3 Conductor Height Measurement.....	41
A.4 Insulation Crimp.....	41
A.5 Pull Force Testing.....	43
Appendix B.....	45

Statistical Process Control (Summary) .....45  
B.1 Crimp Process Control .....46  
B.2 Process Capability .....46  
B.3 Production .....47  
Appendix C .....49  
Options.....49  
Terminal Oiler ..... **Error! Bookmark not defined.**50  
Order No. 63890-0719..... **Error! Bookmark not defined.**50

## Section 1

### General Description

- 1.1 Description
- 1.2 Features
- 1.3 Technical Specifications
- 1.4 Delivery Check
- 1.5 Crimp Tooling Accessories
- 1.6 Tools
- 1.7 Specification Sheets

Principal Mechanical Parts of the FineAdjust Applicator

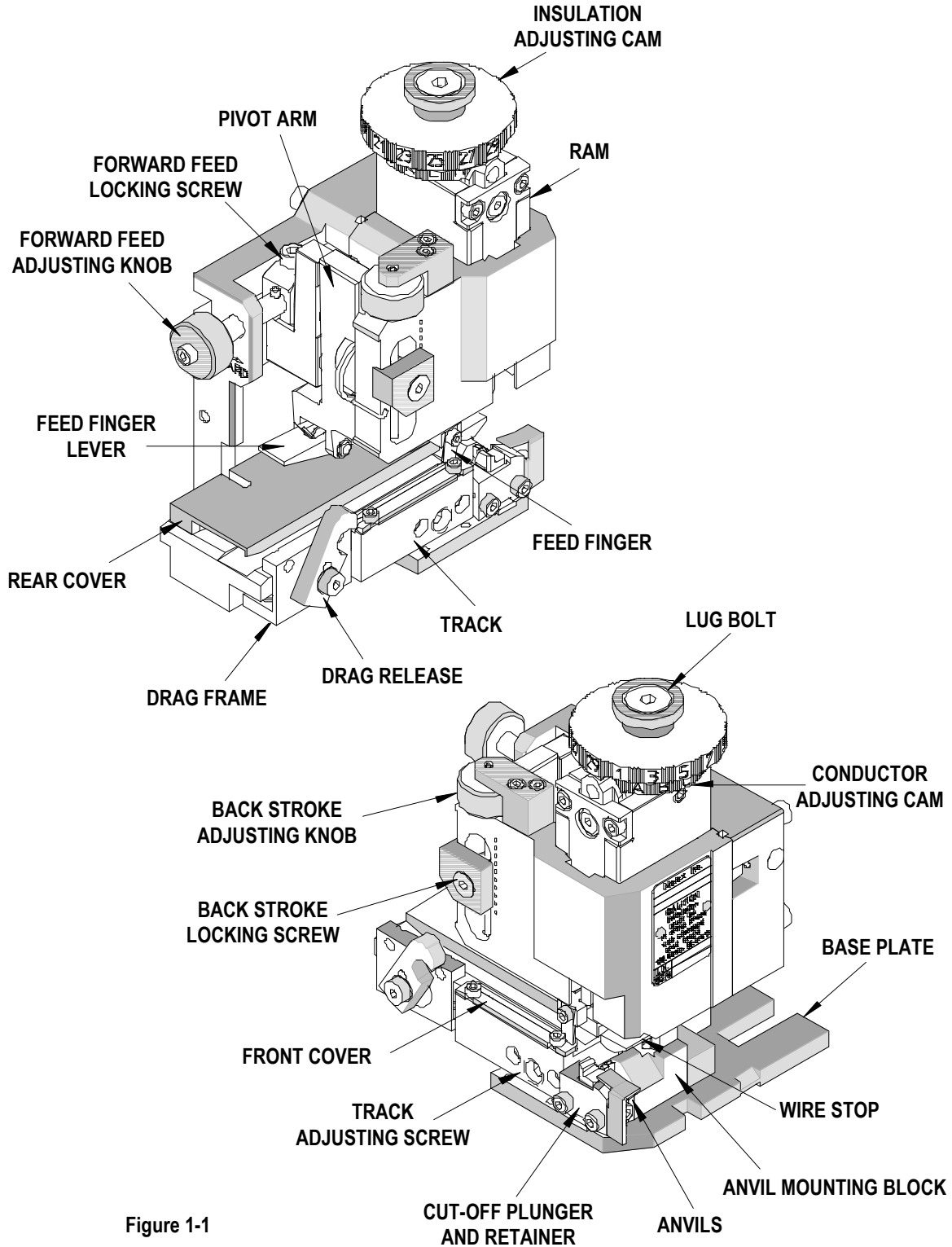

Figure 1-1

## General Description

### 1.1 Description

The Molex FineAdjust™ Applicator is designed to provide an effective method of applying a wide range of side feed terminals to a pre-stripped discrete wire. It is the most advanced version of a "universal" crimping tool available. It is designed to allow for quick adjustments of crimp height, track position, and terminal feed without taking the applicator out of the press and without shimming. This allows easy adjustment of crimp height to the target value with improved process capability, even after a wire change-over.

This applicator works in the Molex TM-2000 and TM-3000 Universal Press and in most industry standard presses. The FineAdjust™ applicator offers minimal setup time without the need for shimming, is versatile, reliable, easy to install, and is designed for mid-volume to high-volume, semi or fully automatic operations.

Molex offers the following crimp presses for operating the Fine Adjust Applicator™:

- ✓ TM-2000 Press 120 V 60 Hz. **63800-8300**
- ✓ TM-2000 Press 240 V 50 Hz. **63800-8400**
- ✓ TM-3000 Press 120 V 60 Hz. **63801-7200**
- ✓ TM-3000 Press 240 V 50 Hz. **63801-7300**
- ✓ TM-4000 Press 240 V 60 Hz. **63801-7600**

The FineAdjust Applicator is also compatible with most OEM presses (Artos, Mecal, Komax, Megomat, Toyojamco, etc). It also adapts to most wire processing machines.

### 1.2 Features

- Fine adjustment allows users to achieve target with little effort by adjusting in increments (14 settings) of .015mm (.0006") for conductor crimp height and (29 settings) in increments of .063mm (.0025") for insulation height.
- Independent adjustment rings allow users to quickly adjust the conductor or insulation crimp height without affecting each other.
- Quick tooling removal with the push of a button for fast and easy punch change.
- Track adjustment for bell mouth and cut-off tab is adjusted while the applicator is in the press for fast and easy setup.
- Compatible with the Molex TM-2000, TM-3000, TM-4000 Universal Press, and most industry standard presses. However, it does NOT fit into Molex TM-40/42 press.

- Directly adapts to most automatic wire processing machines.
- Quick set-up time; plus the crimp height, track and feed adjustments can be preset in applicator.
- Applicator designed to industry standard mounting and shut height 135.80mm (5.346").
- Automatic terminal feed with applicator in press.
- Adjustable terminal feed with applicator in press.
- Terminals are separated from carrier strip automatically during crimping operation.
- Quiet operation with low maintenance and easy to keep clean.
- The FineAdjust™ available for most Molex brand terminals.

### 1.3 Technical Specification

#### Dimensions

Width:	132mm	(5.2")
Depth:	101mm	(4.0")
Height:	152mm	(6.0")

#### Weight

4.1kg (9lbs)

#### Press Stroke Compatibility

41.28mm (1 5/8")  
28.58mm (1 1/8")

#### Guarding

The FineAdjust™ Applicator is supplied with no guards and is intended to be used with the guards supplied by the press manufacturer.



**Caution: DO NOT** use the applicator without guards

### 1.4 Delivery Check

Carefully remove the FineAdjust Applicator from its shipping container and determine that the following items are included in the package.

FineAdjust Applicator (Tooled for desired terminal)	1
11-18-4238 Short Feed Cam	1
Specification Sheets TM-638004900	1
Operation Manual	1
Sample Crimped Terminals	5
Crimp Tooling Accessories	



63890-0719 Terminal Oiler (Appendix C)  
 63800-2800 Digital Crimp Micrometer

The specification sheet should be filed. These are available on the Molex website ([www.molex.com](http://www.molex.com)).

**1.5 Tools**

The following tools are recommended for setup and adjustments to the applicator:

1. Metric standard hex wrench set
2. Adjustable wrench
3. Wire stripper / cutter
4. Scissors

**1.6 Specification Sheets**

Molex ships specification sheets with every applicator. The specification sheet contains the following:

- E** Terminal numbers
- E** Wire AWG ranges
- E** Insulation diameter ranges
- E** Strip lengths
- E** Pull force
- E** Crimp heights
- E** Bell mouth
- E** Bend, twist, and roll limits
- E** Tooling parts list and assembly

FineAdjust Applicator for MX120G Mat. Seal Terminals

<b>FineAdjust Applicator</b>	<b>molex</b> Application Tooling Specification Sheet	 Order No. 63902-6700
----------------------------------	--	--------------------------

**FEATURES**

- Quick punch removal with the push of a button for fast and easy tooling change
- Applicator designed to industry standard mounting and chuck height (32.80mm (1.346"))
- Quick set up time; plus the crimp height, back and feed adjustments can be set without removing the applicator from the press
- Fine adjustment allows users to achieve target with little effort by adjusting in increments of 0.15mm (0.005") for conductor crimp height and 0.3mm (0.012") for insulation height
- Independent adjustment rings allow users to quickly adjust the conductor or insulation crimp height without affecting each other
- Directly adapts to most automatic wire processing machines

**SCOPE**  
 Equipment: MX120G Mat. Seal Plug-in Terminals, 0.75mm<sup>2</sup> wire

Terminal Series No.	Terminal Order No.	Wire Size	Insulation Diameter	Strip Length (mm)
3032	63890-0719	24-26 AWG	1.28-1.39	1.28-1.39
3033	63890-0720	24-26 AWG	1.28-1.39	1.28-1.39

**DEFINITION OF TERMS**

Doc No: ATB-63806700 Release Date: 11-18-12 UNCONTROLLED COPY Page: 1 of 5  
 Revision: A Revision Date: 12-18-12

Fig. 4

Doc No: ATB-63806700 Release Date: 11-18-12 UNCONTROLLED COPY Page: 4 of 5  
 Revision: A Revision Date: 12-18-12

Visit our Web site at <http://www.molex.com>

Doc No: ATB-63806700 Release Date: 11-18-12 UNCONTROLLED COPY Page: 5 of 5  
 Revision: A Revision Date: 12-18-12

triping under power. Check

0.5mm (0.346") Tooling

lock with the press or wire's installation manual

1. applicator and tooling

IS-6203

## Section 2

### Set-Up and Operation

- 2.1. Shut Height
- 2.2. Set-Up
- 2.3. Adjustments
- 2.4. Crimp Tooling Installation and Removal



Read the following instructions before attempting to operate the applicators.

## 2.1 Shut Height

The Molex FineAdjust Applicators are designed to operate in crimp presses with standard shut height of 135.80mm (5.346"). Installation in crimp presses with other than standard shut heights can cause severe tool breakage. It is recommended that before installation, a check of the shut height be performed. The correct shut height is required to prevent the punches from hitting the anvils and the cut-off tooling from bottoming out on the base plate. It also allows the movement of applicators from press to similar press without adjusting the applicator or press shut height.

The shut height of the press can be checked with a shut height gauge, which is calibrated under load to achieve the 135.80mm (5.346") measurement. It is recommended that the shut height be checked monthly. A shut height gauge is available from most press manufacturers.

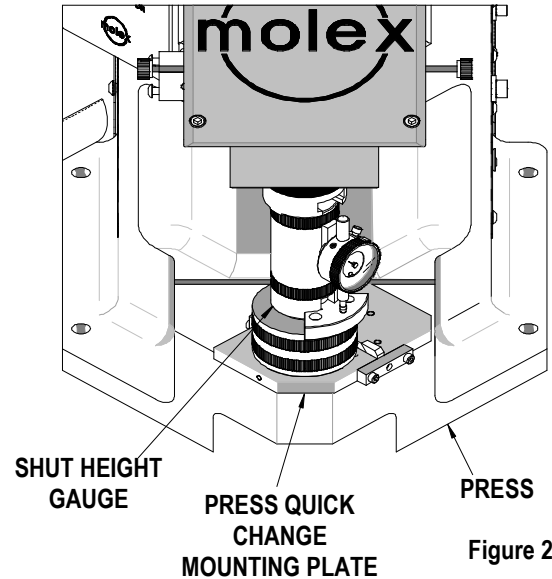

Figure 2-1

### Measuring Press Shut Height

1. Always disconnect the power supply from the press. Remove the machine guards if necessary.
2. Remove the applicator from the press. See "Applicator Installation and Removal" (below) for additional information. Make sure that the bottom of the press ram and quick change mounting plate are free from foreign material.
3. Place the shut height gauge into the press on the press quick change mounting plate. See Figure 2-1.
4. Manually cycle the press to the down stroke position. (Follow press manufacturer's instructions on manually cycling the press.)
5. Read the shut height measurement from the front of the gauge. Follow gauge manufacturers' instruction, usually the gauge reads "0" when set correctly.
6. If adjustments are necessary, refer to the press manufacturer for adjustment of the press shut height.
7. Repeat the above steps until the correct shut height is obtained.
8. Shut height gauges must be calibrated on a regular basis.

## 2.2 Set-Up



### IMPORTANT

Power must be shut off and electrical cord disconnected. Manual press cycling is an absolutely required procedure for safety and preventing equipment damage. Always cycle by hand when trouble shooting or changing adjustments, tooling, applicator, or accessories.

The principal mechanical parts of the FineAdjust are illustrated in Section 4.1 Assembly Drawings.

### Applicator Installation and Removal

- 1 All presses must be equipped with a common universal type quick-change mounting plate and adapter on the press. Contact the press manufacturer for specific information.
- 2 Always turn off and disconnect the power supply to the press. Remove the press guards.
- 3 Clean the quick change mounting plate of scrap or chips that may interfere with the FineAdjust applicator installation.
- 4 For the TM-2000 and TM-3000 Presses follow the procedure below:
  - a. Using a 4mm hex wrench, turn the M5 SHCS clockwise until the locking clamp is fully opened.
  - b. Visually align the applicator base plate slots with the location clamps on the press quick-change mounting plate.

- c. Slide the applicator onto the quick-change mounting plate until the two notches on the left side engage against the stops, and at the same time, guide the lug bolt into the adapter on the press. See Figure 2-2.
  - d. To lock applicator, turn the M5 SHCS counter clockwise until tight.
- 5 Some presses have locking latches on the quick change mounting plate, which have to be flipped up to secure the applicator. Others have knurled finger screws or "T" type latches. Most of these are located on the right side of the quick change mounting plate to secure the position of the applicator. These must be in place and secured before operating the press.
  - 6 Replace the press guards.

Remove the applicator by reversing the previous steps. When storing an applicator, always leave a strip of terminals in the applicator to prevent damage to the tooling. See Section 3.5 Storage.

**Fitting Terminal Strip**

1. The specified terminals are printed on the setup sheet for the applicator. Only use the Molex terminals on the setup sheet which is supplied with the applicator.
2. Always disconnect the power supply from the press. Remove the machine guards if necessary.
3. Rotate the drag release until the drag frame is in the upright position. This will allow the terminal to slide with ease through the applicator track. See Figure 2-3.
4. Push the terminal strip until the first terminal comes to rest centered above the anvil.
5. Rotate the drag release to engage the terminal drag frame.
6. Cycle the press by hand so that the feed finger transfers the next terminal to a centered position over the anvil. Check that all other parts slide and engage without any interference. It is recommended to go through this procedure several times.

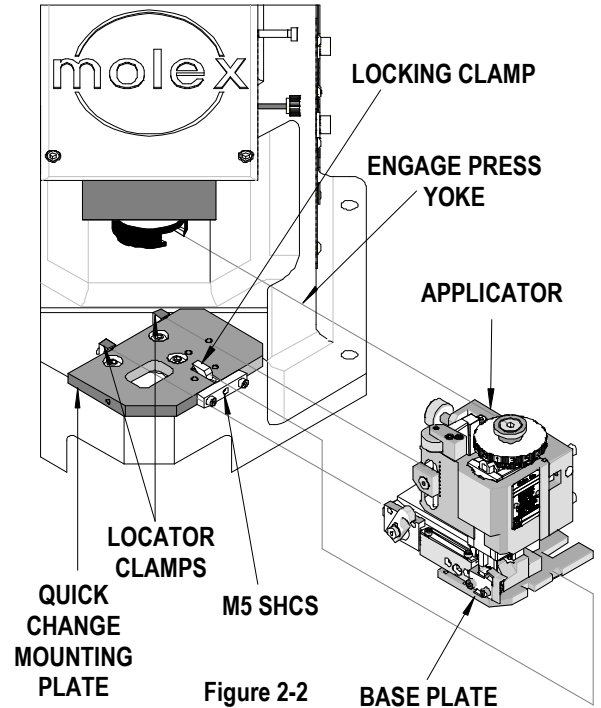

Figure 2-2

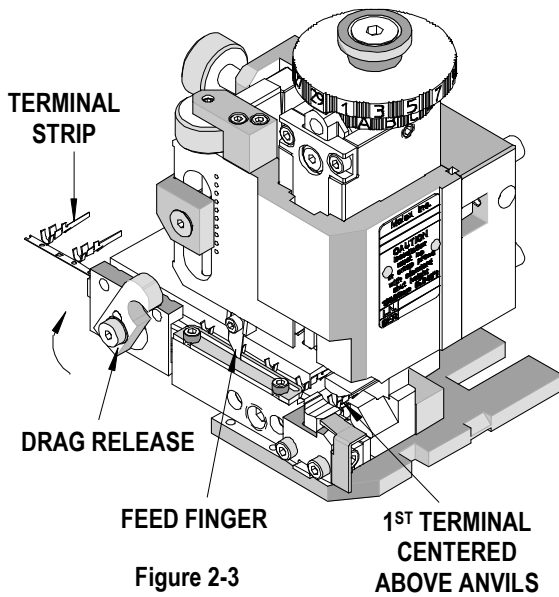

Figure 2-3

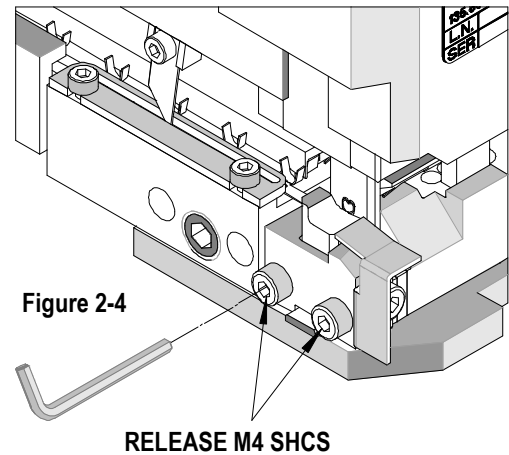

Figure 2-4

7. When unloading the terminal strip, make sure the power is turned off and disconnected from the press. Remove the machine guards if necessary.
8. Rotate the drag release until the drag frame is in the upright position.
9. Raise feed finger and pull terminal strip back until disengaged from applicator track. See Figure 2-3. If preferred, cut the terminal carrier strip and pull it through the applicator with needle nose pliers.
10. Replace the machine guards before operating the press.

### Punch and Anvil Alignments

Note: Always clean mounting surfaces of crimp tooling and tooling holders before alignment.

1. Always disconnect the power supply from the press. Remove the machine guards if necessary.
2. With a terminal in position over the anvils, slightly release anvil mounting screw. See Figure 2-4.
3. Gently hand-cycle the ram of the press to bottom of its stroke. Tighten anvil-mounting screws in this position to ensure perfect alignment of punches and anvils.
4. Hand cycle the press ram to the highest position.
5. Replace the machine guards before operating the press.

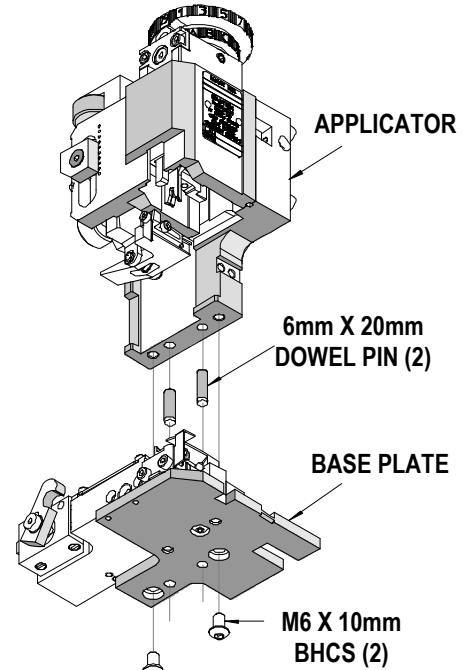

Figure 2-5

### 2.3. Adjustments

#### Cover Plate Adjustments

1. Always disconnect the power supply from the press. Remove the machine guards if necessary.
2. Remove the applicator from the press. Refer to Applicator Installation and Removal.
3. Rotate the drag release until the drag frame is in the upright position. The rear cover plate should be adjusted so that the terminal strip will slide smoothly through the track with no resistance.
4. Some applicators require the removal of the applicator frame from the base plate. This is done by removing the two M6 BHCS located on the bottom of the base plate. See Figure 2-5.
5. Loosen the two M4 BHCS to adjust the position of the rear cover. See Figure 2-6.
6. Slide terminal strip through the track to ensure accurate cover positioning.
7. After the correct position is achieved, tighten the two M4 BHCS.
8. Reattach the applicator frame to the base plate if needed. Locate the position of the frame using the dowel pins. Tighten the two M6 BHCS to secure the frame to the base plate.

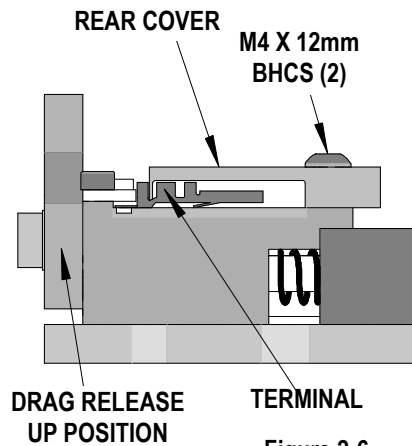

Figure 2-6

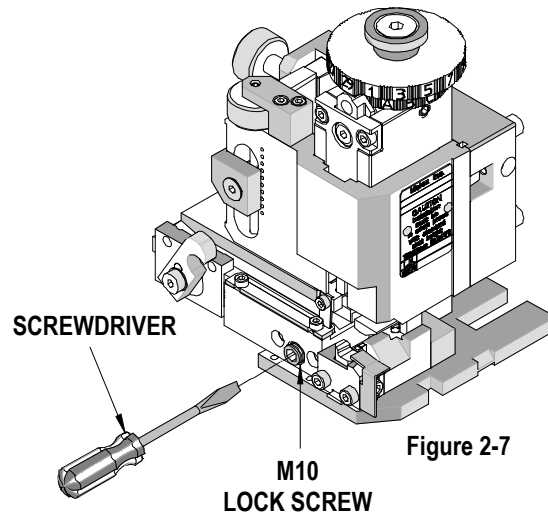

Figure 2-7

#### Track Position Adjustment

1. Disconnect power from the press. Remove the machine guards if necessary.
2. To position the terminal track in or out, first use a 6mm hex wrench to loosen the M10 lock screw located on the front of the track.

3. Put a regular screwdriver through the hole in the lock screw and turn the adjusting screw to position the terminal in the correct location. See Figure 2-7. Turning the screw clockwise will move the track towards the operator; to move the track towards the applicator turn the screw counterclockwise. Depending on the amount of movement, the feed finger mount may need to be loosened and readjusted. See Feed Finger adjustment.
- 7 To lock the track in position, tighten the M10 lock screw.
- 8 If the feed finger mount was loosened during the track positioning, remember to tighten its mounting screw.
- 9 Replace machine guards.
- 10 Hand cycle the press to ensure the terminal is positioned properly on the anvils and does not have an excessive cutoff tab. Also, verify the terminal feed operation.
- 11 Restore power to the press, crimp a terminal under power, and observe the quality of the termination.
- 12 Repeat the above steps until the desired terminal position is obtained.

**Feed Finger Adjustments**

1. Position the feed finger to properly feed the next terminal in position. Typically, terminals are fed by the carrier strip.
2. Depending on the feed cam installation (pre-feed or post-feed), move the press ram until the feed is forward (this makes the feed finger mount more accessible), and then disconnect power from the press. Remove the machine guards if necessary.
3. Using a 2.5mm hex wrench, loosen the M3 SHCS located on the feed finger mount. While holding the feed finger lever down slightly, slide the feed finger to the desired position. See Figure 2-8.
4. If the feed finger mount cannot be moved far enough, remove the M3 SHCS completely and install it in another tapped hole in the feed finger lever. In addition, the feed finger mount can be reversed (the feed finger must be reversed as well) to gain additional adjustment.
5. Tighten the M3 SHCS to lock the feed finger in position.

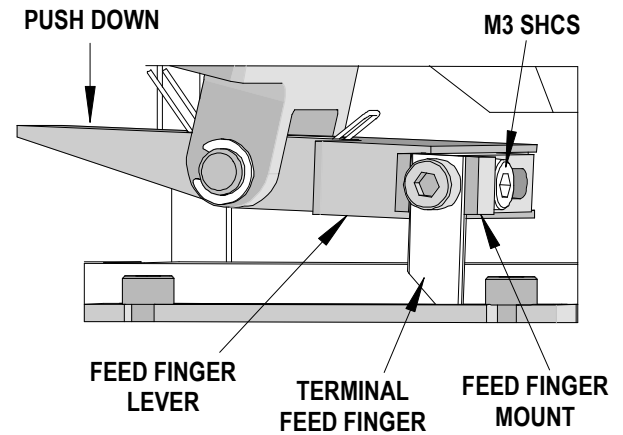

Figure 2-8

**Feed Stroke Cam Adjustments**

1. The terminal feed stroke is driven by a cam mounted to the applicator ram. Two feed cams are shipped with the applicator. The standard cam is installed in the applicator. The spare cam is for presses with short strokes (for example, 28mm). Using the standard cam with a short-stroke press may result in insufficient feed stroke or incorrect feed timing.
2. Determine what feed timing is desired. Typically, when the applicator is mounted in a wire processing machine, the feed stroke cam should be assembled in the down stroke position. While the press is idle in the up position, a terminal will not be present over the anvil. For most bench applications, the cam is installed in the up stroke position. This will leave a terminal over the anvil when the press is idle in the up position. See Figure 2-9.
3. Turn off and disconnect the power supply from the press. Remove the machine guards if necessary.
4. Remove the applicator from the press. See Applicator Installation and Removal.
5. Pull back on the feed pivot lever and remove the ram from the applicator.
6. Holding on to the ram, use a 3mm hex wrench to remove the M4 SHCS holding the cam on the back of the ram.
7. Position the cam in the desired position for feeding and attach with the M4 screw. See Figure 2-9.

Feed Cam Order No.	Press Stroke		Feed Timing
	mm	In.	
 63800-0305	41.28	1-5/8	Up stroke (terminal present over anvil)
	28.58	1-1/8	
 63800-0305	41.28	1-5/8	Down stroke (terminal not present over anvil)
 11-18-4238	28.58	1-1/8	Down stroke (terminal not present over anvil)

Figure 2-9



### Forward Feed Adjustments

1. The forward feed position must locate the terminal that is being crimped exactly over the anvils.
2. Disconnect the power from the press. Remove the machine guards if necessary.
3. Make sure there is a terminal over the anvils and the feed finger is fully forward (closest to the anvils).
4. Loosen the M5 SHCS.
5. Turn the forward feed adjusting knob to position the terminal. To decrease the feed position, turn the forward feed adjusting knob clockwise. To increase the feed position turn the forward feed adjusting knob counterclockwise. See Figure 2-10.
6. When adjusting to decrease the feed position, it is necessary to pull the terminal strip backwards until it is against the feed finger. When increasing the feed position, the feed finger will push the terminal farther over the anvils.
7. After properly adjusting the forward feed position of the terminal, tighten the M5 SHCS with a 4mm hex wrench.

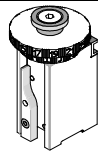
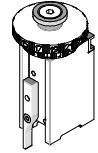
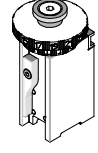
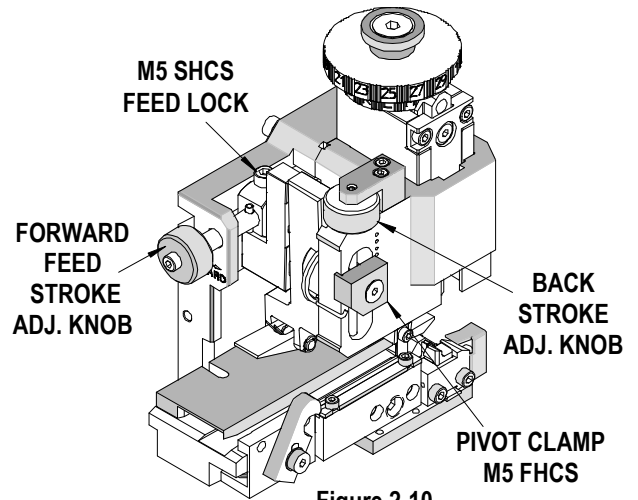

Figure 2-10

### Back Stroke Feed Adjustments

1. To properly feed the terminal strip, the back feed stroke should have enough over-travel to pick up the next terminal. Too much over travel may, in some cases, cause a double-feed.
2. Disconnect the power from the press. Remove the machine guards if necessary.
3. To achieve the correct backstroke location, adjust the position of the hinge bushing. First, use a 3mm hex wrench to loosen the M5 FHCS holding the pivot clamp. Turning the backstroke adjustment knob (which is located above the hinge bushing) clockwise will raise the hinge bushing and will increase the backstroke. Turning the knob counter clockwise (CCW) will lower the hinge bushing and will decrease the feed backstroke. When adjustment is complete, tighten the pivot clamp securely. See Figure 2-10.
4. Since back feed stroke adjustment may not be visibly obvious, the terminal feed should be cycled (by hand, if possible) to observe the changes.
5. Back feed stroke adjustments may affect the entire feed linkage; re-adjustment of the forward feed stroke could be necessary. See Forward Feed Adjustments.

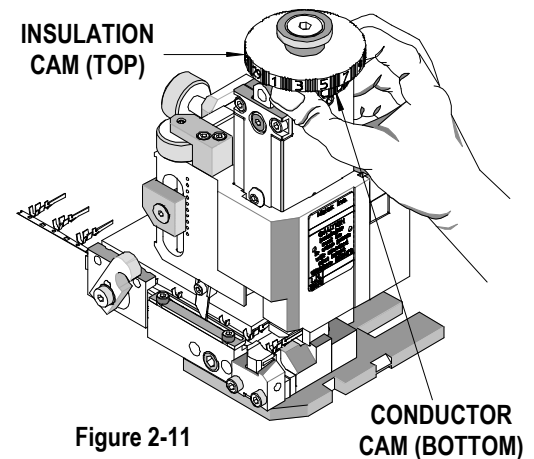

Figure 2-11

### Conductor Crimp Punch Adjustments

1. With the guards intact, place a stripped length of suitable wire into the terminal and terminate the wire under power.
2. Inspect the quality of conductor crimp and measure the crimp height. See Appendix A.3 Conductor Crimp Height Measurement.
3. If adjustments are necessary, turn off and disconnect the power supply from the press. Remove the machine guards.
4. The desired crimp height can be achieved by rotating the conductor-adjusting cam. See Figure 2-11. Each increment represents approximately 0.015mm (.0006") for a total adjustment of 1.80mm (.071"). The "A" setting is the loosest crimp height and the "N" setting is the tightest. If you find that the crimp height is not acceptable, you can rotate the adjusting cam until the desired crimp height is obtained. See Section 2.1, Shut Height. No shimming of the applicator is required.
5. Replace the machine guards and repeat the previous steps until the desired crimp height is obtained. See Appendix A.3, Conductor Crimp Height Measurement.
6. Perform a pull test on conductor crimp to verify the mechanical integrity of the crimp. See Appendix A.5, Pull Force Test.

### Insulation Crimp Punch Adjustment

1. Place a stripped length of the appropriate wire into the terminal and crimp under power.
2. Observe quality of insulation crimp and measure the crimp height. See Appendix A.4, Insulation Crimp.
3. If adjustments are necessary, always turn off and disconnect the power supply from the press. Remove the machine guards.
4. Rotate the insulation-adjusting cam to achieve the desired insulation height. Each increment represents approximately 0.06mm (.0025") for a total adjustment of 3.00mm (.118"). The "1" setting is for the highest (most loose) crimp height and the "29" setting the lowest (most tight) crimp height.
5. Repeat the previous steps until the desired insulation height is obtained.

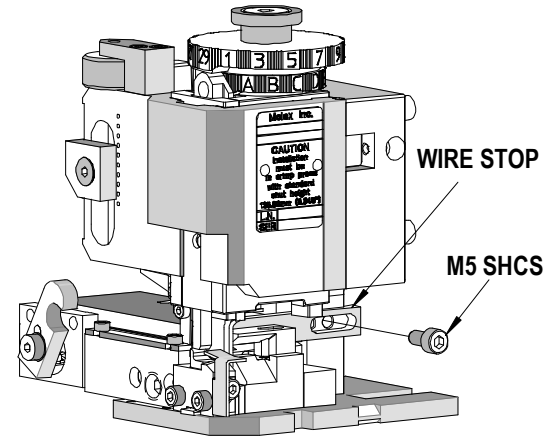

Figure 2-12

**Note:** Due to the large variety of insulation wall thickness, materials, and diameter, Molex does not specify insulation crimp height. For each different wire type, the insulation crimp height can be measured, recorded, and inspected as a quality indicator.

### Wire Stop Adjustment

For automatic wire processing machines, the wire stop can be used to assist in the stripping of the terminal from the punches. However, in certain circumstances the wire stop will need to be removed when running on an automated machine.

1. Check the setup documents to obtain the correct strip length.
2. Place the correct wire into the terminal and crimp the wire under power.
3. Observe quality of crimp and the wire position. See Appendix A.1 Conductor Brush and Terminal Position.
4. If adjustments are necessary, turn off and disconnect the power supply from the press. Remove the machine guards.
5. Use a 4mm hex wrench to loosen the M5 SHCS located on the side of the frame. See Figure 2-12.
6. Adjust the position of the wire stop by moving the wire stop, towards the operator decreases the brush length and towards the press increases it.
7. Tighten the M5 SHCS.
8. Hand cycle the press to ensure the applicator is functioning properly. Then crimp a terminal under power and observe the quality of the termination.

## 2.4 Crimp Tooling Installation and Removal

### Installation and Removal of the Upper Tooling (Punches)



**Caution:** Always disconnect power supply before installing or removing tooling.

**NOTE:** Always clean mounting surfaces of crimp tooling and tooling holders before installation.

1. Always turn off and disconnect the power supply from the press. Remove the machine guards if necessary.
2. Remove the applicator from the press. See Section 2.2, Applicator Installation and Removal.
3. Pull back the feed arm and remove the ram from the applicator.
4. With a small screw driver, push in the punch release button located on the front of the ram. See Figure 2-13.
5. Pull the punches out the bottom of the ram.
6. Reverse the previous steps to reinstall the punches.

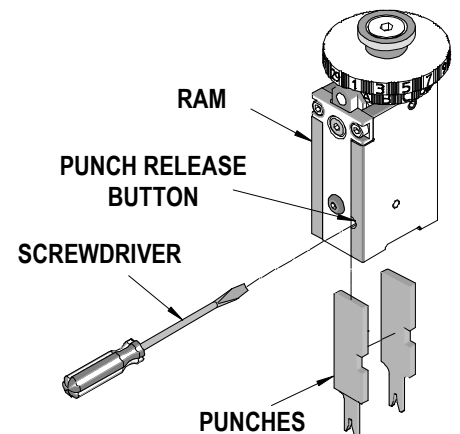

Figure 2-13



**Installation and Removal of the Lower Tooling (Anvils)**



**Caution:** Always disconnect power supply before installing or removing tooling.

**NOTE:** Always clean mounting surfaces of crimp tooling and tooling holders before installation.

1. Always turn off and disconnect the power supply from the press. Remove the machine guards if necessary.
2. Make sure the ram is all the way in the up position.
3. Remove the M4 SHCS that are holding the lower tooling in place and pull out the tooling. See Figure 2-14.
4. Put in the new anvils, leaving the mounting screws loose. For tightening, see Section 2.2, Punch and Anvil Alignment.

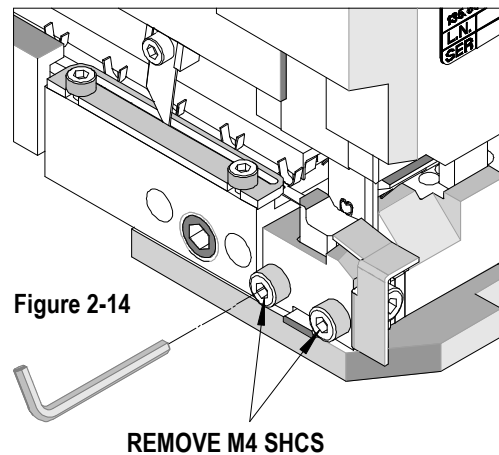

Figure 2-14

**REMOVE M4 SHCS**

## Section 3

### Maintenance

- 3.1 Cleaning
- 3.2 Lubrication
- 3.3 Spare parts
- 3.4 Perishable Parts
- 3.5 Storage

### 3.1 Cleaning



**Caution:** Always disconnect power supply before installing or removing tooling.

For efficient operation, the FineAdjust Applicator should be cleaned daily. Use a soft bristle brush to remove debris from critical areas such as the crimp tooling. For best results, remove the crimp tooling from the press. Brush and then use a clean cloth to wipe off the upper and lower tooling mounting areas. Before reinstalling tooling, wipe all sides of the punches and anvils with a clean cloth.

### 3.2 Lubrication



**WARNING:** Disconnect electrical power before all maintenance.

1. Grease the ram including the cam.
2. Oil the feed finger assembly and all moving parts.
3. Lubricate with multipurpose synthetic lubricant with Teflon or an equivalent. Molex ships its applicators pre-greased with Permatex multi-purpose synthetic grease with Teflon No. 82329. A SAE 30WT non-detergent oil or light spindle oil or 3-n-1 oil should be used on pivot points.



**WARNING:** Never use penetrants such as WD40 for any lubrication on the machine.

4. Lubricate all points shown in Figures 3-1 with the specified oil and grease (or equivalent).

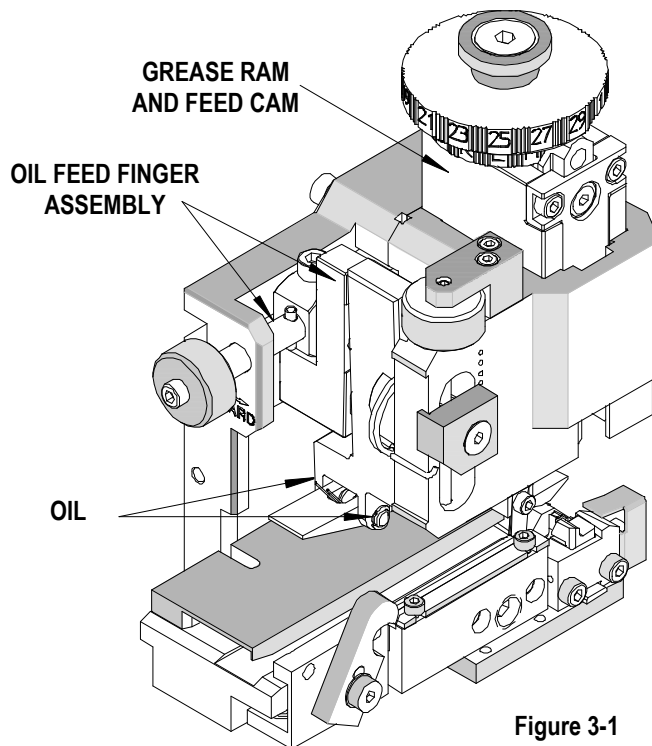

Figure 3-1

An example of a maintenance chart is shown below. Copy and use this chart to track the maintenance of your FineAdjust Applicator or use this as a template to create you own schedule or use your company's standard chart, if applicable.

## Preventive Maintenance Chart

**Daily:** Clean. See Section 3.1.

**As Required:** Lubricate. See Section 3.2.

CHECK SHEET MONTH \_\_\_\_\_ YEAR \_\_\_\_\_

Week	Daily Cycles	Daily Clean	Days of the Week							Solution
			MON	TUE	WED	THU	FRI	SAT	SUN	
1										
2										
3										
4										
Cleaning Reapply grease Reapply oil	25,000	Yes								Soft Brush Industrial Degreaser
Inspect all tooling, feed fingers etc. for wear	25,000	Yes								Replace if signs of wear.

Schedule should be adjusted up or down depending on usage. Molex recommends that a log of preventive maintenance be kept with the press.

### 3.3 Spare Parts

Customers are responsible for maintaining the FineAdjust Applicator. Spare parts are available. Moving and functioning parts can be damaged or wear out over time and will require replacement. Molex recommends that the customer keep some or all of them in stock to reduce production down time.

### 3.4 Perishable Parts

Customers are responsible for maintaining the FineAdjust Applicator. Perishable parts are those parts that come in contact with the product and will wear out over time. Molex recommends that all customers keep at least one set of the perishable tool kits in stock at all times. This will reduce the amount of production down time. **For the proper perishable tool kit information, refer to the Crimp Tooling Specification Sheet supplied with the Applicator.**

#### Tooling Replacement Schedule

The following is offered as a general guideline for tooling replacement. The manufacturer should monitor the process and collect data on actual frequency as tool wear varies on different terminal materials and tool life can be increased with good maintenance practices or decrease with lack of maintenance.

Items	Cycles Brass Alloys	Cycles Steel	Actual
Punches	300,000/500,000	200,000/400,000	
Anvils	500,000/750,000	400,000/750,000	
Cut-off Plungers	300,000/500,000	200,000/400,000	
Feed Fingers	300,000/900,000	300,000/900,000	
Cut-off Punches	500,000/750,000	200,000/400,000	
Cut-off Blades	300,000/500,000	200,000/300,000	

Judgment on tool replacement should be based on the attributes of the crimp they produce.

See the following chart for common signs of wear.

<b>Punches</b>	<b>On Terminal</b>	<b>Notes</b>
Scoring	Uneven Curls	Replace
Tip Loss	Open seam	Replace
<b>Anvils</b>		
Rounded Edges	Large Extrusion	Replace
Chipping	Burrs-On Tabs	Replace
Worn Cut Edges	Burrs	Replace
<b>Cut-Off Plungers and Punches</b>		
Chipped or Rounded	Burr on Tab	Replace
Cut Edge	Burr on Tab	Replace
Cut-off Dies	Burrs on Cut Area	Replace

### 3.5 Storage

To prevent the bottoming of the ram, which can cause damage to the crimp punches and anvils leave a strip of terminals in the applicator or place a piece of wood or rubber between the punches and the anvils.

## Section 4

### Parts Lists, Assembly Drawings and Troubleshooting

- 4.1 Style A FineAdjust Applicator
- 4.2 Style B FineAdjust Applicator
- 4.3 Style C FineAdjust Applicator
- 4.4 Troubleshooting

Styles of FineAdjust

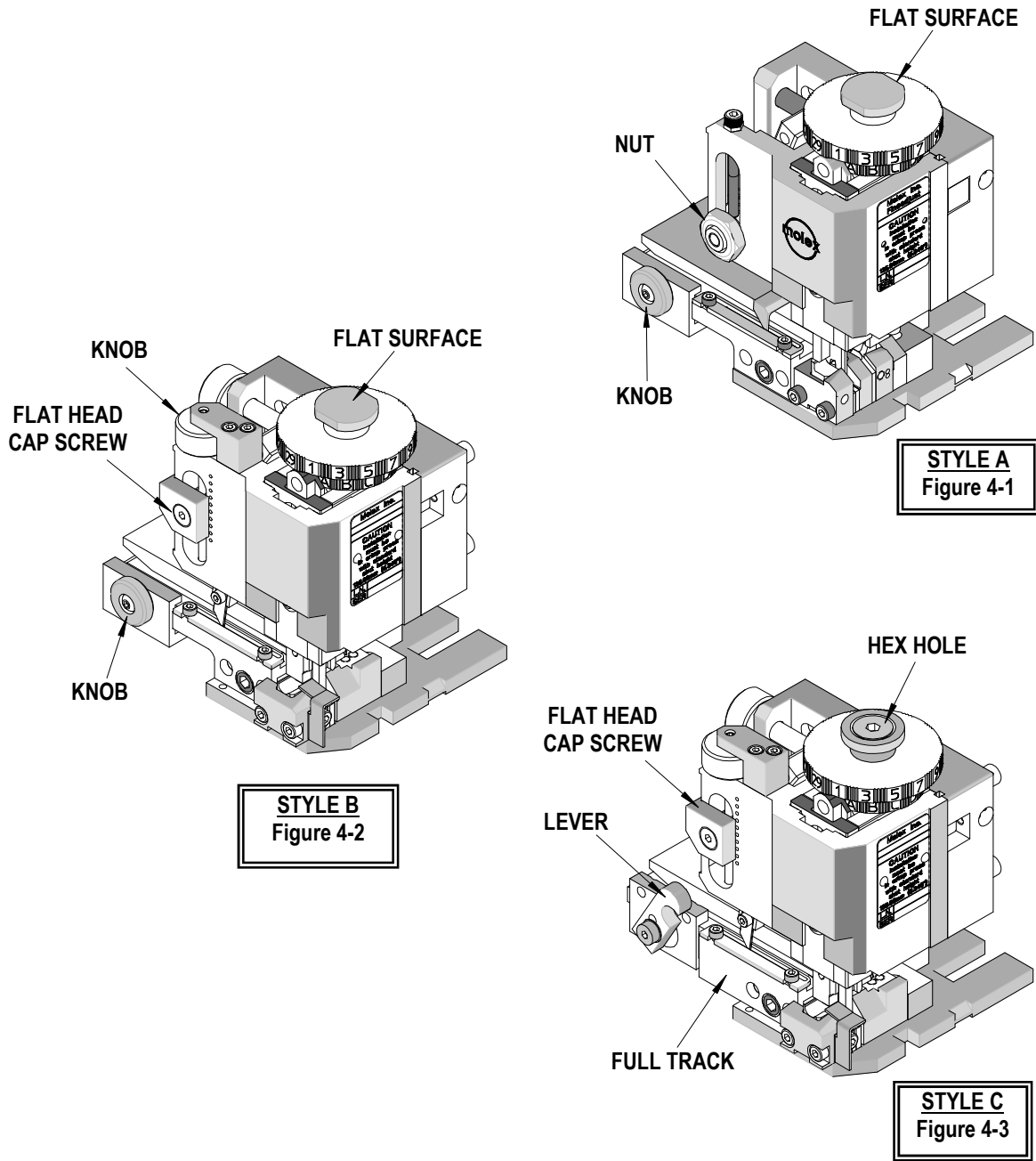

In the effort to continually improve the FineAdjust Applicator, we have multiple styles working in the field. To determine the style of applicator you are using, look at the pictures above. Figure 4-1, 4-2, and 4-3 point out the major differences between the styles of this applicator. Identify your applicator style and use the appropriate parts list and assembly drawing to order replacement parts.

## 4.1 STYLE A-FineAdjust Applicator

Parts List and Assembly Drawings (See Figure 4-4 and 4-5)

STYLE A-FineAdjust Applicator				
Item	Order No.	Engineering No.	Description	Qty
1	11-18-4238	60700-1	Feed Cam (Short) Optional	1
2	11-32-5346	60000Y422	M4 Ball Spring Plunger	4
3	11-41-0127	60678-27	Compression Spring (Associated # C0180-016-0500)	1
4	63600-0481	63600-0481	Shoulder Screw M5 by 10mm Long	1
5	63800-0115	63800-0115	Spacer Tube	1
6	63800-0117	63800-0117	Feed Pawl Lever	1
7	63800-0118	63800-0118	Hinge Bushing	1
8	63800-0119	63800-0119	Feed Finger	1
9	63800-0120	63800-0120	Feed Arm	1
10	63800-0121	63800-0121	Lever Feed Pivot	1
11	63800-0122	63800-0122	Feed Adjusting Screw	1
12	63800-0123	63800-0123	Slider-Feed Cam	1
13	63800-0124	63800-0124	Pin-Feed Adjusting	1
14	63800-0125	63800-0125	Torsion Spring-Hinge	1
15	63800-0127	63800-0127	Torsion Spring-Feed Pawl	1
16	63800-0129	63800-0129	Washer -3.40mm Thick	1
17	63800-0140	63800-0140	Cylinder Pin	1
18	63800-0141	63800-0141	Slider	1
19	63800-0142	63800-0142	Roller-Cam Follower	1
20	63800-0143	63800-0143	Pin-Cam Follower	1
21	63800-0144	63800-0144	Key Stock 3mm by 3mm by 29mm Long	2
22	63800-0301	63800-0301	Back Frame	1
23	63800-0302	63800-0302	Face Plate	1
24	63800-0303	63800-0303	Base Plate	1
25	63800-0304	63800-0304	Ram-Terminator Tooling	1
26	63800-0305	63800-0305	Feed Cam	1
27	63800-4906	63800-4906	Insulation Striker	1
28	63800-0308	63800-0308	Terminal Track	1
29	63800-4309	63800-4309	Rear Support Block	1
30	63800-0310	63800-0310	Adjusting Screw	1
31	63800-0311	63800-0311	Locking Screw	1
32	63800-0312	63800-0312	Drag Frame	1
33	63800-0313	63800-0313	Drag Cam	1
34	63800-0314	63800-0314	Retaining Bar	1
35	63800-0316	63800-0316	Guide Pin-Drag Frame	2
36	63800-0330	63800-0330	Lug Bolt	1
37	63800-0331	63800-0331	Conductor Adjusting Cam	1
38	63800-0332	63800-0332	Insulation Adjusting Cam	1
39	63800-0335	63800-0335	Serial Tag	1
40	63800-0345	63800-0345	Retaining Plate	1
41	63800-4946	63800-4946	Conductor Striker	1
42	63800-0347	63800-0347	Retaining Rod	1
43	63800-0348	63800-0348	Detent Spacer	1
44	N/A	N/A	Compression Spring (Lee Spring # LC-032E-0MW)	4**
45	N/A	N/A	Extension Spring (Lee Spring #LE-041C-9)	1**
46	N/A	N/A	Snap Ring 3.2mm ID by 7mm OD by .62mm Thick	2**
47	N/A	N/A	Washer .512" ID by 1.125" OD by 0.15" Thick	1**
48	N/A	N/A	Washer .512" ID by 1.125" OD by 0.18" Thick	1**



STYLE A-FineAdjust Applicator				
Item	Order No.	Engineering No.	Description	Qty
49	N/A	N/A	M3 by 6mm Long FHCS	2**
50	N/A	N/A	M4 Hex Nut	1**
51	N/A	N/A	M4 by 8mm Long BHCS	1**
52	N/A	N/A	M4 by 8mm Long SHCS	3**
53	N/A	N/A	M4 by 10mm Long Set Screw	1**
54	N/A	N/A	M4 by 12mm Long BHCS	2**
55	N/A	N/A	M4 by 45mm Long SHCS	1**
56	N/A	N/A	M5 by 6mm Long BHCS	1**
57	N/A	N/A	M5 by 10mm Long SHCS	1**
58	N/A	N/A	M5 by 35mm Long SHCS	4**
59	N/A	N/A	M6 by 10mm Long BHCS	2**
60	N/A	N/A	M6 by 8mm Long Set Screw	1**
61	N/A	N/A	M12 Self Locking Hex Nut	1**
62	N/A	N/A	3mm by 12mm Long Roll Pin	2**
63	N/A	N/A	5mm by 20mm Long Dowel Pin	1**
64	N/A	N/A	5mm by 25mm Long Dowel Pin	1**
65	N/A	N/A	6mm by 10mm Long Dowel Pin	1**
66	N/A	N/A	6mm by 12mm Long Dowel Pin	2**
67	N/A	N/A	6mm by 20mm Long Dowel Pin	1**
68	N/A	N/A	6mm by 45mm Long Dowel Pin	2**
69	N/A	N/A	#2 (.098 Dia.) by .125 in. Long Drive Screw	2**
** Available from an industrial supply company such as MSC (1-800-645-7270).				

Check Applicator Number Tag or Part Number on part when ordering.

4.1 STYLE A FineAdjust Applicator Assembly

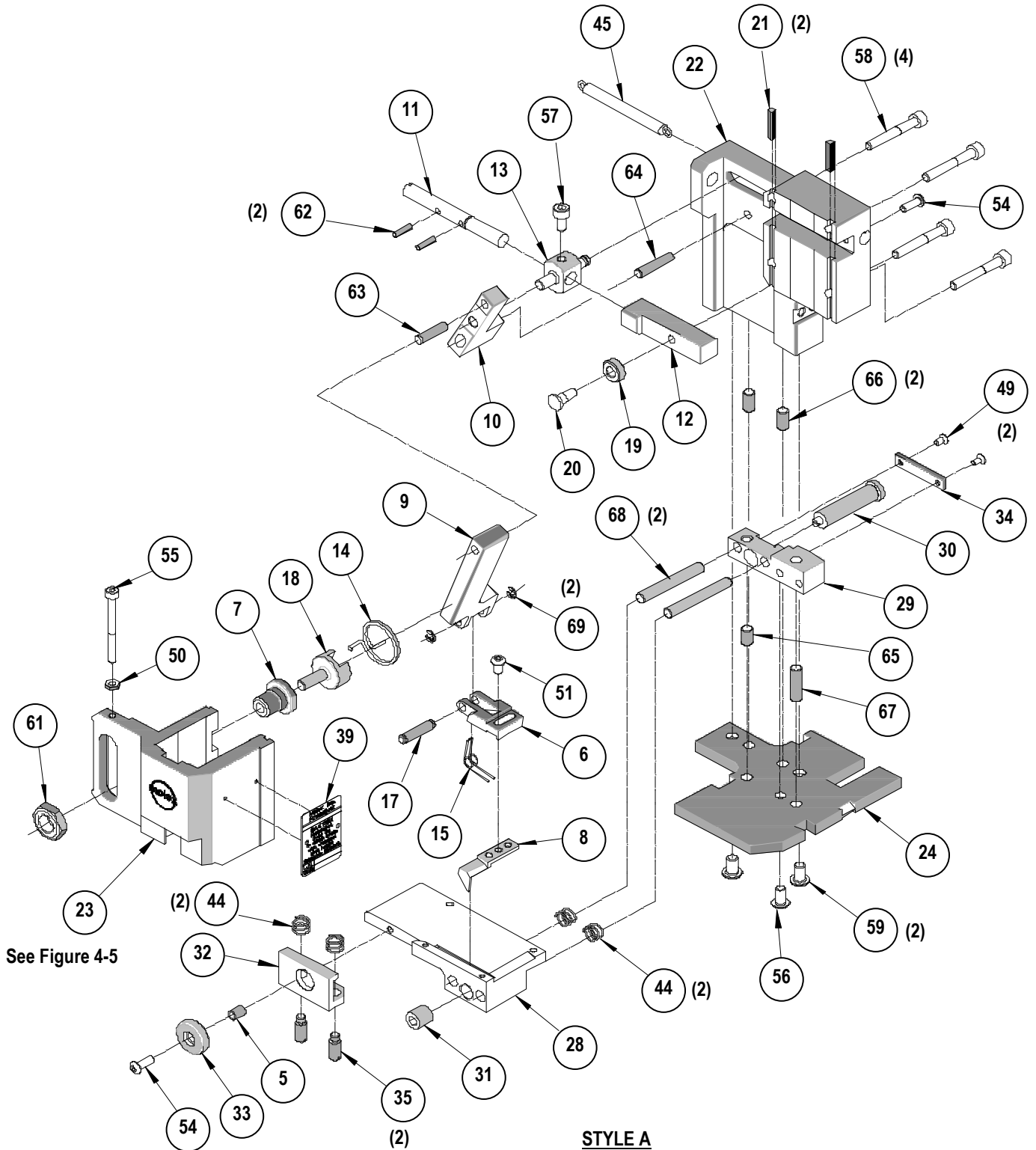

STYLE A  
Figure 4-4

4.1 STYLE A FineAdjust Applicator Assembly (Cont.)

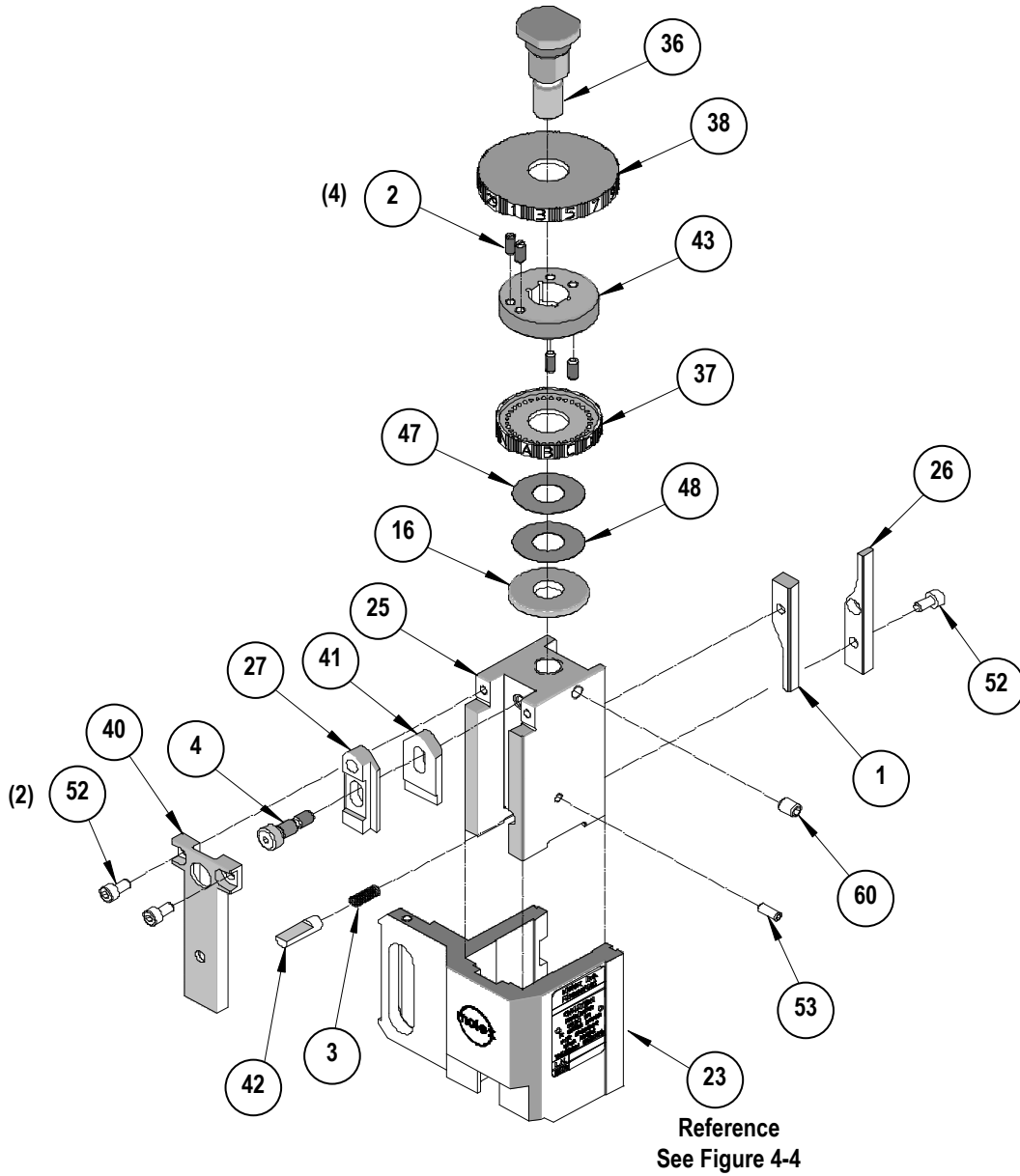

**STYLE A**  
Figure 4-5

**4.2 STYLE B-FineAdjust Applicator**

Parts List and Assembly Drawings (See Figure 4-6 and 4-7)

STYLE B-FineAdjust Applicator				
Item	Order No.	Engineering No.	Description	Qty
1	11-18-4238	60700-1	Feed Cam (Short) Optional	1
2	11-32-5346	60000Y422	M4 Ball Spring Plunger	4
3	11-41-0127	60678-27	Compression Spring (Associated # C0180-016-0500)	1
4	63600-0481	63600-0481	Shoulder Screw M5 by 10mm Long	1
5	63800-0115	63800-0115	Spacer Tube	1
6	63800-0120	63800-0120	Feed Arm	1
7	63800-0121	63800-0121	Lever Feed Pivot	1
8	63800-0123	63800-0123	Slider-Feed Cam	1
9	63800-0124	63800-0124	Pin-Feed Adjusting	1
10	63800-0127	63800-0127	Torsion Spring-Feed Pawl	1
11	63800-0140	63800-0140	Cylinder Pin	1
12	63800-0142	63800-0142	Roller-Cam Follower	1
13	63800-0143	63800-0143	Pin-Cam Follower	1
14	63800-0144	63800-0144	Key Stock 3 by 3 by 19mm Long	2
15	63800-0304	63800-0304	Ram-Terminator Tooling	1
16	63800-0308	63800-0308	Terminal Track	1
17	63800-0310	63800-0310	Adjusting Screw	1
18	63800-0311	63800-0311	Locking Screw	1
19	63800-0312	63800-0312	Drag Frame	1
20	63800-0313	63800-0313	Drag Cam	1
21	63800-0314	63800-0314	Retaining Bar	1
22	63800-0316	63800-0316	Guide Pin-Drag Frame	2
23	63800-0330	63800-0330	Lug Bolt	1
24	63800-0331	63800-0331	Conductor Adjusting Cam	1
25	63800-0332	63800-0332	Insulation Adjusting Cam	1
26	63800-0345	63800-0345	Retaining Plate	1
27	63800-0347	63800-0347	Retaining Rod	1
28	63800-0348	63800-0348	Detent Spacer	1
29	63800-4309	63800-4309	Rear Support Block	1
30	63800-4902	63800-4902	Face Plate	1
31	63800-4906	63800-4906	Insulation Striker	1
32	63800-4946	63800-4946	Conductor Striker	1
33	63801-0129	63801-0129	Washer 3.40mm Thick	1
34	63801-3202	63801-3202	Feed Cam	1
35	63801-3211	63801-3211	Back Frame	1
36	63801-3225	63801-3225	Torsion Spring	1
37	63801-3281	63801-3281	Base Plate	1
38	63801-4462	63801-4462	Feed Finger Mount	1
39	63801-4561	63801-4561	Feed Finger	1
40	63890-0817	63890-0817	Feed Pawl Lever	1
41	63890-0881	63890-0881	Adjusting Screw	1
42	63890-0883	63890-0883	Adjusting Knob Retainer	1
43	63890-0884	63890-0884	Adjustable Pivot	1
44	63890-0885	63890-0885	Slider	1
45	63890-0886	63890-0886	Feed Positioning Screw	1
46	63890-0887	63890-0887	Pivot Clamp	1
47	63890-0899	63890-0899	Feed Adjusting Knob	2
48	63890-0999	63890-0999	Serial Tag	1

STYLE B-FineAdjust Applicator				
Item	Order No.	Engineering No.	Description	Qty
49	69028-0660	69028-0660	Compression Spring (Lee Spring # LC-032E-0MW)	4**
50	N/A	N/A	#2 (.098 in. Diameter) by .125 in. Long Drive Screw	2**
51	N/A	N/A	M3 by 5mm Long SHCS	1**
52	N/A	N/A	M3 by 6mm Long FHCS	2**
53	N/A	N/A	M3 by 12mm Long SHCS	1**
54	N/A	N/A	M3 by 20mm Long SHCS	2**
55	N/A	N/A	M4 by 8mm Long SHCS	3**
56	N/A	N/A	M4 by 8mm Long Set Screw	1**
57	N/A	N/A	M4 by 10mm Long Set Screw	1**
58	N/A	N/A	M4 by 12mm Long BHCS	3**
59	N/A	N/A	M4 by 16mm Long SHCS	1**
60	N/A	N/A	M5 by 6mm Long BHCS	1**
61	N/A	N/A	M5 by 8mm Long FHCS	1**
62	N/A	N/A	M5 by 10mm Long SHCS	1**
63	N/A	N/A	M5 by 35mm Long SHCS	4**
64	N/A	N/A	M6 by 8mm Long Set Screw	1**
65	N/A	N/A	3mm by 12mm Long Roll Pin	2**
66	N/A	N/A	5mm by 20mm Long Dowel Pin	1**
67	N/A	N/A	5mm by 25mm Long Dowel Pin	1**
68	N/A	N/A	6mm by 10mm Long Dowel Pin	2**
69	N/A	N/A	6mm by 20mm Long Dowel Pin	2**
70	N/A	N/A	6mm by 45mm Long Dowel Pin	2**
71	N/A	N/A	Extension Spring (Lee Spring #LE-041C-9)	1**
72	N/A	N/A	Snap Ring 3.2mmID by 7mm OD by .62mm Thick	2**
73	N/A	N/A	Washer .512" ID by 1.125" OD by 0.15" Thick	1**
74	N/A	N/A	Washer .512" ID by 1.125" OD by 0.18" Thick	1**

\*\* Available from an industrial supply company such as MSC (1-800-645-7270).

### 4.2 STYLE B FineAdjust Applicator Assembly

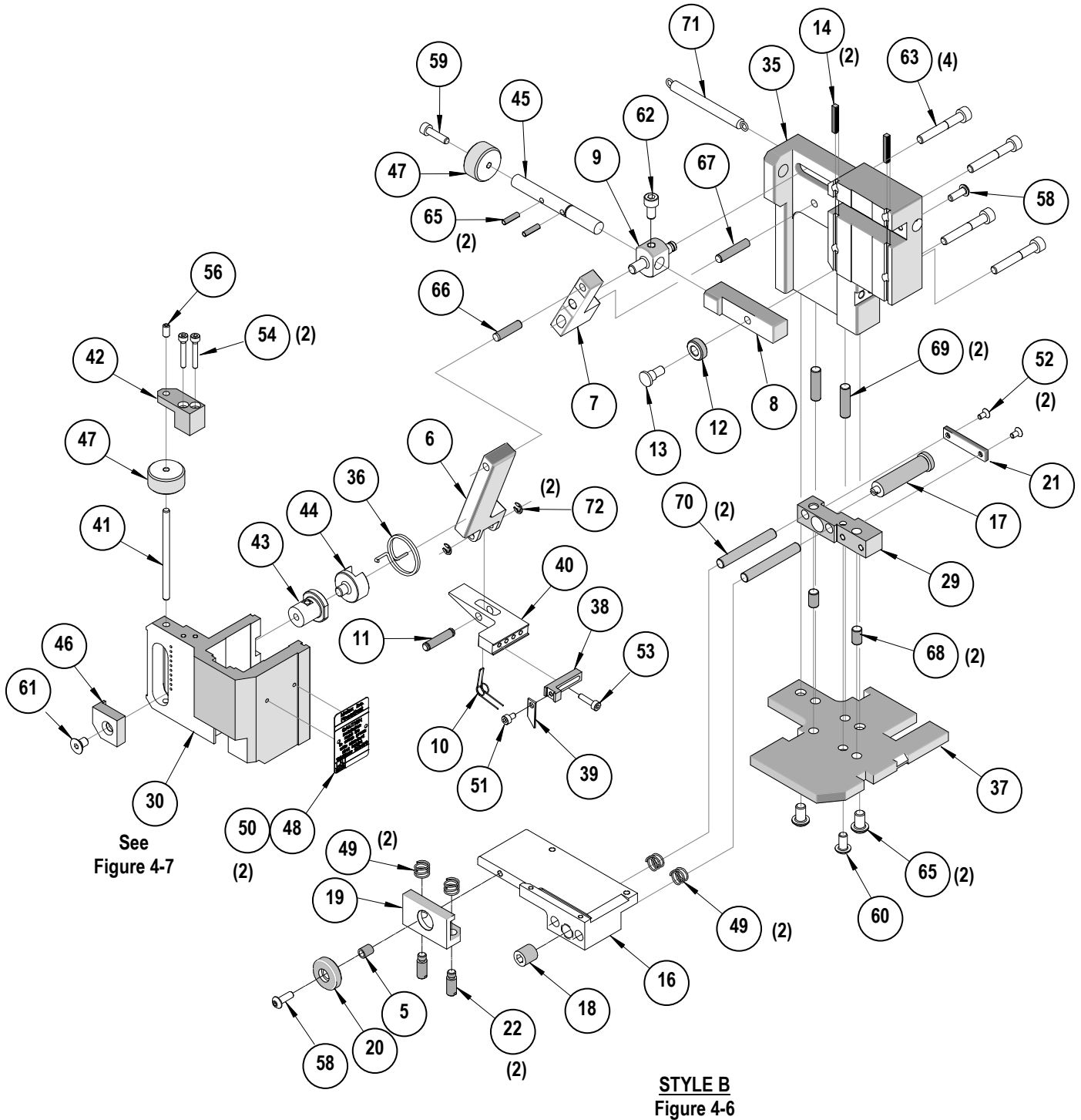

4.2 STYLE B FineAdjust Applicator Assembly (Cont.)

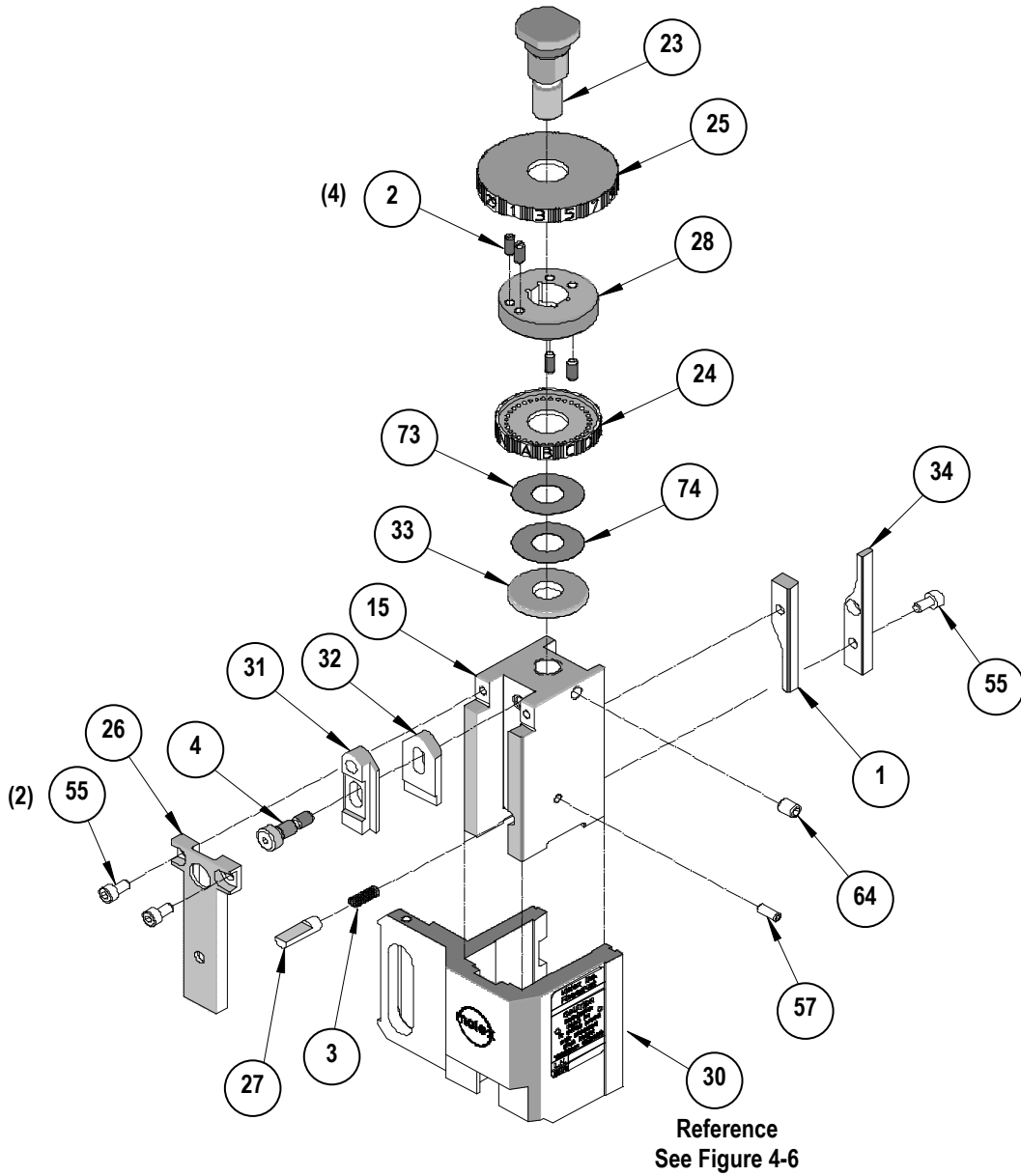

**STYLE B**  
Figure 4-7

## 4.3 STYLE C-FineAdjust Applicator

Parts List and Assembly Drawings (See Figure 4-8 and 4-9)

STYLE C-FineAdjust Applicator-				
Item	Order No.	Engineering No.	Description	Qty
1	11-18-4238	60700-1	Feed Cam (Short) Optional	1
2	11-32-5346	60000Y422	M4 Ball Spring Plunger	5
3	11-41-0127	60678-27	Compression Spring (Associated # C0180-016-0500)	1
4	63443-6202	63443-6202	Terminal Track	1
5	63600-0481	63600-0481	Shoulder Screw M5 by 10mm Long	1
6	63600-1561	63600-1561	Washer 6 I.D. by 10 O.D. by 0.3mm Thick	1
7	63600-2644	63600-2644	Stripper Bolt 6 O.D. by 10mm Long	1
8	63800-0120	63800-0120	Feed Arm	1
9	63800-0121	63800-0121	Lever Feed Pivot	1
10	63800-0123	63800-0123	Slider-Feed Cam	1
11	63800-0124	63800-0124	Pin-Feed Adjusting	1
12	63800-0127	63800-0127	Torsion Spring-Feed Pawl	1
13	63800-0140	63800-0140	Cylinder Pin	1
14	63800-0142	63800-0142	Roller-Cam Follower	1
15	63800-0143	63800-0143	Pin-Cam Follower	1
16	63800-0144	63800-0144	Key Stock 3 by 3 by 19mm Long	2
17	63800-0304	63800-0304	Ram-Terminator Tooling	1
18	63800-0310	63800-0310	Adjusting Screw	1
19	63800-0311	63800-0311	Locking Screw	1
20	63800-0312	63800-0312	Drag Frame	1
21	63800-0314	63800-0314	Retaining Bar	1
22	63800-0316	63800-0316	Guide Pin-Drag Frame	2
23	63800-0345	63800-0345	Retaining Plate	1
24	63800-0347	63800-0347	Retaining Rod	1
25	63800-4309	63800-4309	Rear Support Block	1
26	63800-4903	63800-4903	Face Plate	1
27	63800-4906	63800-4906	Insulation Striker	1
28	63800-4946	63800-4946	Conductor Striker	1
29	63801-3202	63801-3202	Feed Cam	1
30	63801-3211	63801-3211	Back Frame	1
31	63801-3225	63801-3225	Torsion Spring	1
32	63801-3281	63801-3281	Base Plate	1
33	63801-4462	63801-4462	Feed Finger Mount	1
34	63801-4561	63801-4561	Feed Finger	1
35	63801-5862	63801-5862	Drag Cam Lever	1
36	63801-6444	63801-6444	Conductor Adjusting Cam	1
37	63801-6445	63801-6445	Insulation Adjusting Cam	1
38	63801-6446	63801-6446	Detent Spacer	1
39	63801-6447	63801-6447	Ram Adapter	1
40	63890-0817	63890-0817	Feed Pawl Lever	1
41	63890-0885	63890-0885	Slider	1
42	63890-0881	63890-0881	Adjusting Screw	1
43	63890-0883	63890-0883	Adjusting Knob Retainer	1
44	63890-0884	63890-0884	Adjustable Pivot	1
45	63890-0886	63890-0886	Feed Positioning Screw	1
46	63890-0887	63890-0887	Pivot Clamp	1
47	63890-0899	63890-0899	Feed Adjusting Knob	2
48	63890-0999	63890-0999	Serial Tag	1



STYLE C-FineAdjust Applicator-				
Item	Order No.	Engineering No.	Description	Qty
49	69028-0660	69028-0660	Compression Spring (Lee Spring # LC-032E-0MW)	4**
50	N/A	N/A	#2 (.098 in. Diameter) by .125 in. Long Drive Screw	2**
51	N/A	N/A	M3 by 5mm Long SHCS	1**
52	N/A	N/A	M3 by 6mm Long FHCS	2**
53	N/A	N/A	M3 by 12mm Long SHCS	1**
54	N/A	N/A	M3 by 20mm Long SHCS	2**
55	N/A	N/A	M4 by 8mm Long SHCS	3**
56	N/A	N/A	M4 by 8mm Long Set Screw	1**
57	N/A	N/A	M4 by 10mm Long Set Screw	1**
58	N/A	N/A	M4 by 12mm Long BHCS	1**
59	N/A	N/A	M4 by 16mm Long SHCS	1**
60	N/A	N/A	M5 by 6mm Long BHCS	1**
61	N/A	N/A	M5 by 8mm Long FHCS	1**
62	N/A	N/A	M5 by 10mm Long SHCS	1**
63	N/A	N/A	M5 by 35mm Long SHCS	4**
64	N/A	N/A	M6 by 8mm Long Set Screw	1**
65	N/A	N/A	M6 by 10mm Long BHCS	2**
66	N/A	N/A	M8 by 20mm Long FHCS	1**
67	N/A	N/A	3mm by 12mm Long Roll Pin	2**
68	N/A	N/A	5mm by 20mm Long Dowel Pin	1**
69	N/A	N/A	5mm by 25mm Long Dowel Pin	1**
70	N/A	N/A	6mm by 10mm Long Dowel Pin	2**
71	N/A	N/A	6mm by 20mm Long Dowel Pin	2**
72	N/A	N/A	6mm by 45mm Long Dowel Pin	2**
73	N/A	N/A	Extension Spring (Lee Spring #LE-041C-9)	1**
74	N/A	N/A	Snap Ring 3.2mm ID by 7mm OD by .62mm Thick	2**
** Available from an industrial supply company such as MSC (1-800-645-7270).				

### 4.3 STYLE C FineAdjust Applicator Assembly

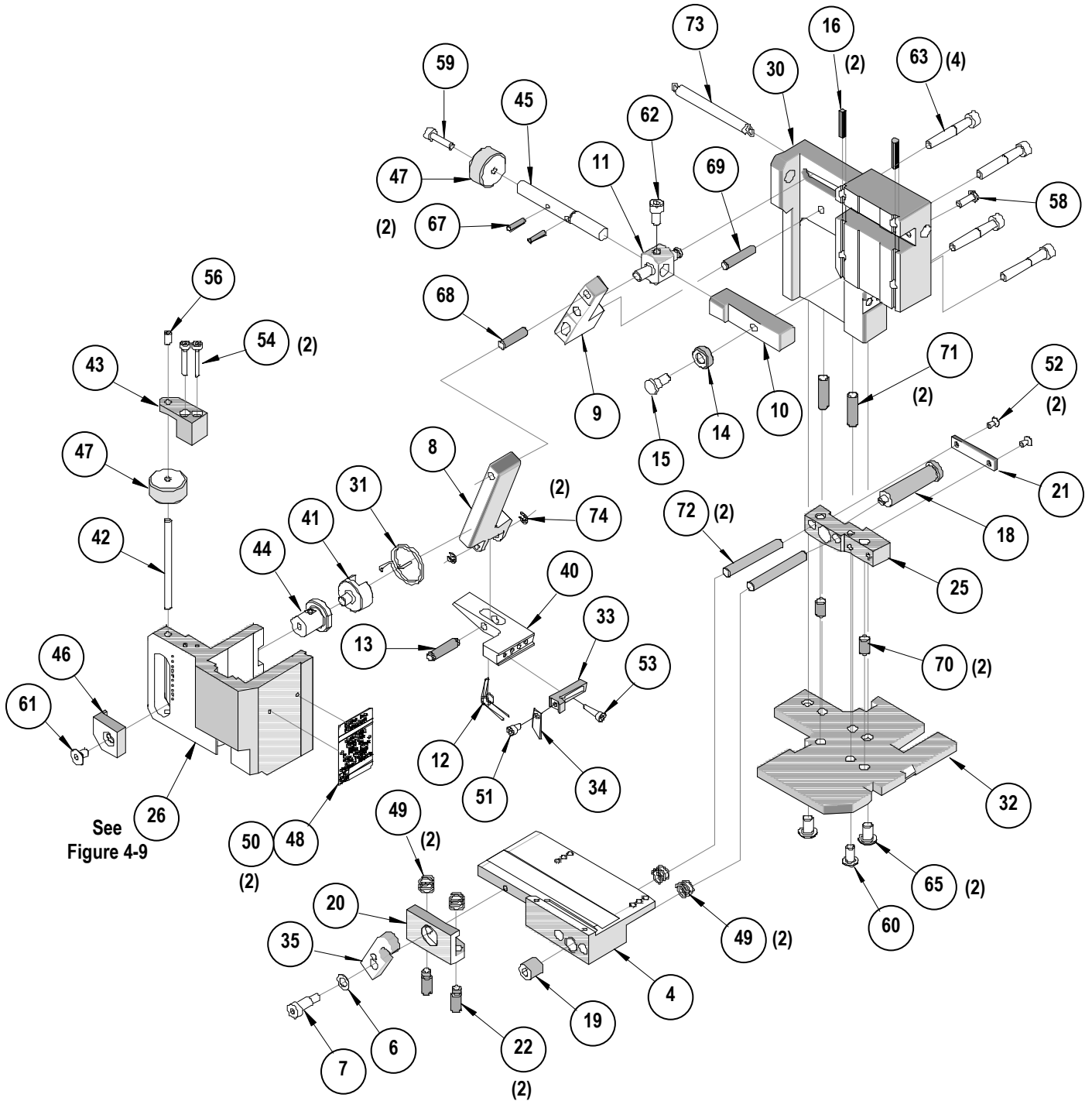

**STYLE C**  
Figure 4-8

4.3 STYLE C FineAdjust Applicator Assembly (Cont.)

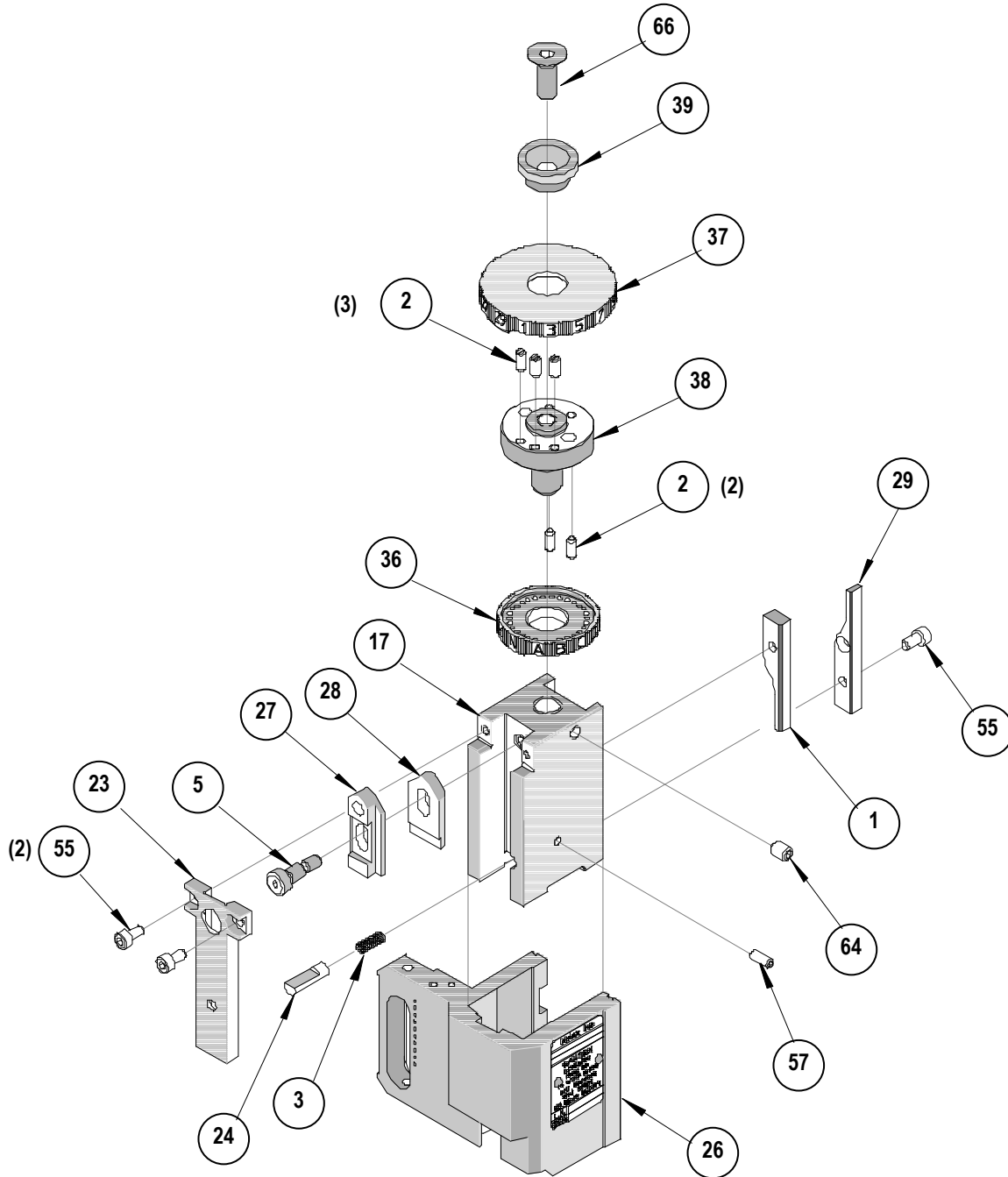

**STYLE C**  
Figure 4-9

Reference  
See Figure 4-8

#### 4.4 Troubleshooting

Symptom	Cause	Solution
Terminals not feeding	▪ Terminals bent or damaged	Replace terminals
	▪ Feed finger worn or not properly adjusted	Check proper finger setting
	▪ Drag plate not holding terminal strip back	Check compression springs
	▪ Terminal jammed under cover plate	Clear and reinsert terminals
Excessive Bellmouth	▪ Conductor punch worn	Replace
	▪ Track out of position	Adjust base and track for proper alignment with the punches and anvil
Cut-off plunger does not return to original position	▪ Cut-off plunger adjusted too tight against anvil	Readjust
	▪ Cut-off plunger spring damaged or broken	Replace spring
	▪ Cut edges worn, plunger sides or plunger retainer scored	Remove scoring marks. If problem not solved, replace with new cut-off parts
Conductor crimp is too loose	▪ Wrong tooling	Replace with proper tooling
	▪ Tooling worn or damaged	Replace tooling
	▪ Wrong cam setting	Back off one setting
	▪ Press shut height too high	Calibrate press shut height
Conductor crimp is too tight	▪ Wrong tooling	Replace with proper tooling
	▪ Cam out of adjustment	Readjust conductor cam
	▪ Press shut height is too low	Calibrate press shut height
Insulation crimp is too tight	▪ Cam out of adjustment	Readjust insulation cam
	▪ Wrong tooling	Replace with proper tooling
	▪ Press shut height is too low	Calibrate press shut height
Terminal sticks during crimping	▪ Wrong tooling	Replace with proper tooling
	▪ Tooling worn or damaged	Replace tooling
	▪ Gold plating and/or some high tensile materials	Install a terminal oiler. See Appendix C

**For more information use the Quality Crimping Handbook**

There is no charge for this book, which can be found on the Molex Website ([www.molex.com](http://www.molex.com)) or contact your local Molex sales engineer

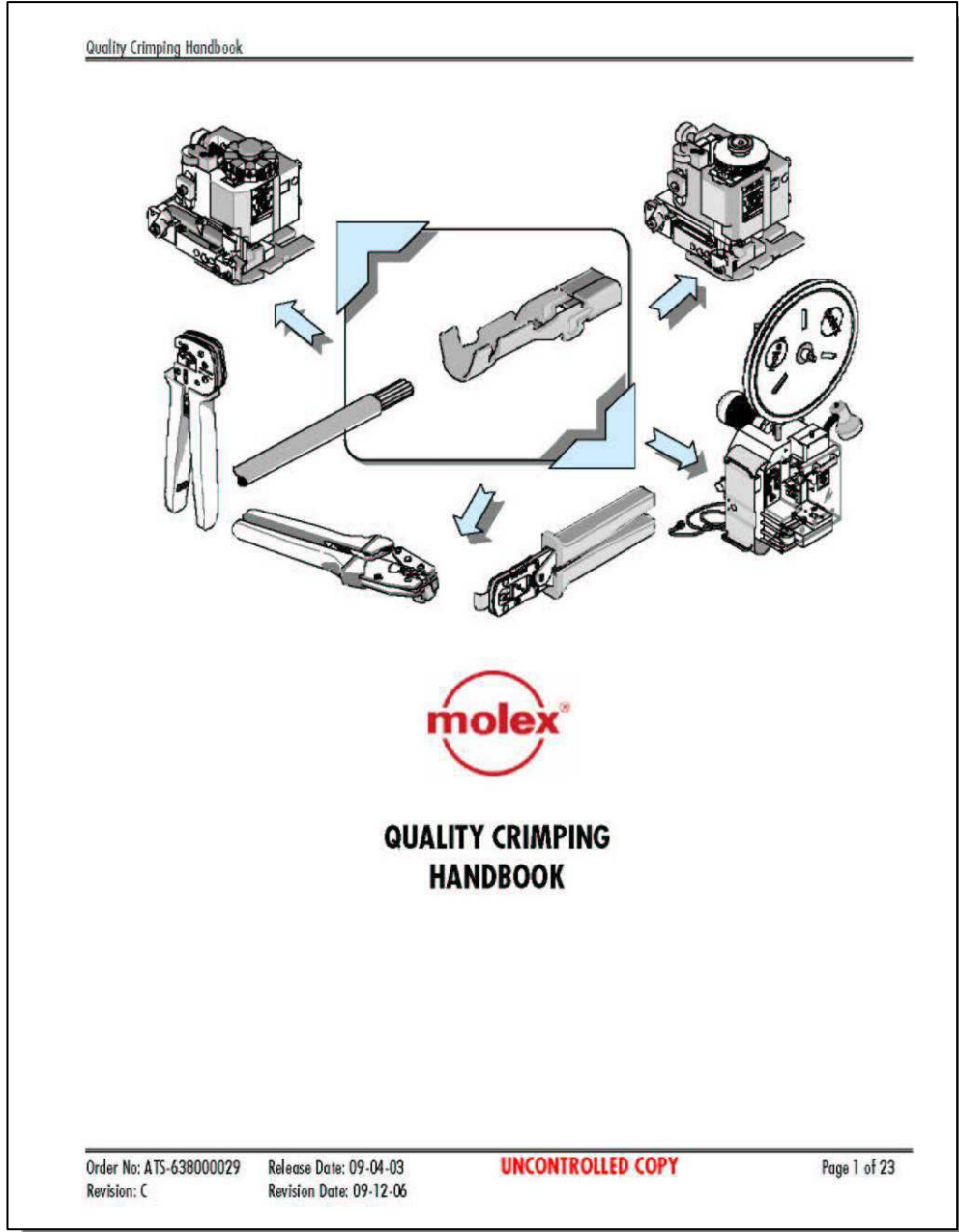

**Appendix A**  
**Crimp Terminations**

- A.1 Conductor Brush and Terminal Position
- A.2 Conductor Bell mouth and Terminal Cut-off Tab
- A.3 Conductor Crimp Height Measurement
- A.4 Insulation Crimp
- A.5 Pull Force Testing

## Terminal Terminology

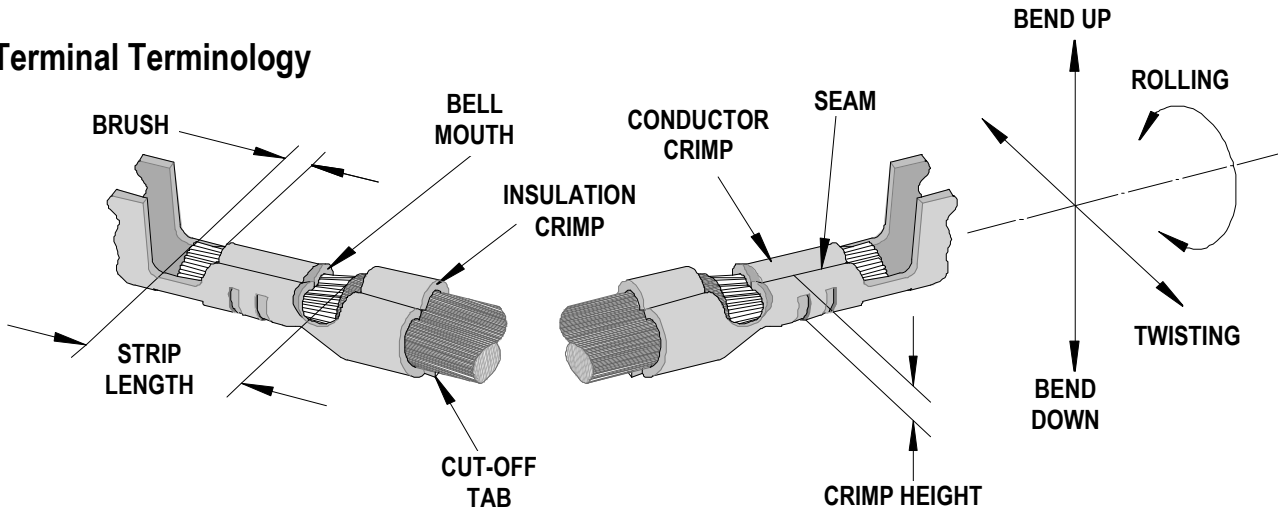

### A.1 Conductor Brush and Terminal Position

<p>Figure A-1</p>	<p><b>A-1 Optimum crimp setup</b></p> <p>The insulation edge should be centered in the middle of the transition area. The conductor brush should extend past the conductor crimp and not extend into the contact area.</p>
<p>Figure A-2</p>	<p><b>A-2 Insulation under conductor crimp (with a good conductor brush length)</b></p> <p><b>Cause:</b> Strip length too short.  <b>Solution:</b> Verify strip length specification and adjust as necessary.</p>
<p>Figure A-3</p>	<p><b>A-3 Insulation under conductor crimp, (with a long conductor brush length)</b></p> <p><b>Cause:</b> Wire stop position incorrect.  <b>Solution:</b> Adjust wire stop to center the insulation in the transition area.</p>
<p>Figure A-4</p>	<p><b>A-4 Insulation under conductor crimp, (with a short or no conductor brush length)</b></p> <p><b>Cause:</b> 1) Strip length too short and                  2) Wire stop position incorrect.  <b>Solution:</b> 1) Verify strip length specification and adjust as necessary.                  2) Adjust wire stop to center the insulation in the transition area.</p>
<p>Figure A-5</p>	<p><b>A-5 Insulation edge centered in the transition area, (with the conductor brush too long)</b></p> <p><b>Cause:</b> 1) Strip length too long.                  2) Irregular wire cut-off or wire strands pulled from insulation bundle.  <b>Solution:</b> 1) Verify strip length specification and adjust as necessary.                  Readjust wire stop for bench applications.                  2) Check for worn stripping blades</p>
<p>Figure A-6</p>	<p><b>A-6 Insulation edge under insulation grip, (with the conductor brush too short)</b></p> <p><b>Cause:</b> Strip length too long.  <b>Solution:</b> Verify strip length specification and adjust as necessary.                  Readjust wire stop for bench applications.</p>

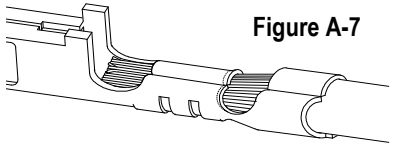
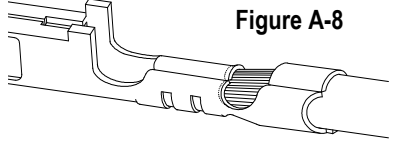
 <p style="text-align: center;"><b>Figure A-7</b></p>	<p><b>A-7 Insulation edge under insulation crimp, (with a good or wrong conductor brush length)</b>  <b>Cause:</b> Strip length too long.  <b>Solution:</b> Verify strip length specification and adjust as necessary. Adjust the wire stop.</p>
 <p style="text-align: center;"><b>Figure A-8</b></p>	<p><b>A-8 Insulation edge under insulation crimp, (with a short or no conductor brush length)</b>  <b>Cause:</b> 1) Wire stop position incorrect.                  2) Operator not consistently using the wire stop.  <b>Solution:</b> 1) Adjust the wire stop to center the insulation in the transition area.                  2) Operator training, reduce crimping rate.</p>

**A.2 Conductor Bell Mouth and Terminal Cutoff Tab**

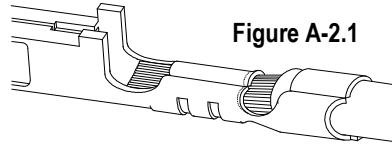
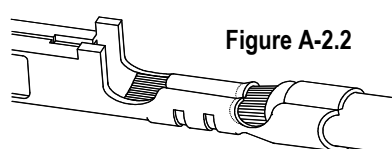
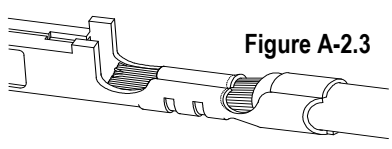
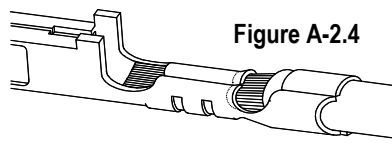
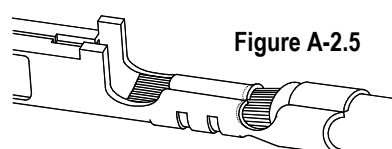
 <p style="text-align: center;"><b>Figure A-2.1</b></p>	<p><b>A-2.1 Optimum crimp setup</b>                  Tooling was set up to produce conductor bell mouth to nominal specification and/or approximately 1x to 2x terminal material thickness. The cutoff tab is approximately 1x terminal material thickness.</p>
 <p style="text-align: center;"><b>Figure A-2.2</b></p>	<p><b>A-2.2 Excessive bell mouth, cut-off tab flush with Insulation crimp</b>  <b>Cause:</b> 1) Wrong conductor crimp tooling used.                  2) Camber in the terminal strip.  <b>Solution:</b> 1) Verify that correct tooling is installed.                  2) Adjust terminal track into the applicator.</p>
 <p style="text-align: center;"><b>Figure A-2.3</b></p>	<p><b>A-2.3 No or small bell mouth, long cut-off tab</b>  <b>Cause:</b> 1) Wrong conductor crimp tooling used.                  2) Camber in the terminal strip.  <b>Solution:</b> 1) Verify that correct tooling is installed.                  2) Adjust terminal track towards the operator.</p>
 <p style="text-align: center;"><b>Figure A-2.4</b></p>	<p><b>A-2.4 Excessive Bell mouth, good cut-off tab</b>  <b>Cause:</b> 1) Worn conductor punch tooling.                  2) Incorrect conductor punch tooling.  <b>Solution:</b> Replace tooling if necessary</p>
 <p style="text-align: center;"><b>Figure A-2.5</b></p>	<p><b>A-2.5 Excessive Cutoff Tab, Good Conductor Bell mouth</b>  <b>Cause:</b> 1) Worn cutoff tooling.                  2) Incorrect cut-off tooling.  <b>Solution:</b> Replace tooling if necessary.</p>



### A.3 Conductor Height Measurement

**NOTE:** Conductor height should be measured with a blade type micrometer or a caliper.

**CAUTION:** Care must be taken not to measure the extrusions

#### A.3.1 Crimp height off target

- Cause:**
- 1) Changed wire type, stranding or vendor.
  - 2) Changed insulation diameter.
  - 3) Changed crimp tooling.
  - 4) Changed crimping press.(Shut-height)
  - 5) Changed press type. (Manufacturer)
  - 6) Changed terminal reel. (Lot code)
  - 7) Changed tooling set-up.
  - 8) Damaged or worn tooling.

**Solution:** Adjust tooling back to target  
(Refer to Section 2)

#### A.3.2 Crimp height variability too high

- Cause:**
- 1) Wire variability.
  - 2) Terminal variability.
  - 3) Damaged, loose, or worn tooling.
  - 4) Measurement error \*.
  - 5) Cut or missing wire strands.

- Solution:**
- 1 or 2) Inspect incoming product for variability.
  - 3) Tooling replacement or tightening.
  - 4) Gauge capability analysis.
  - 5) Tooling crimp height adjustment.
  - 6) Stripping process adjustment.

\* Most common cause of crimp height variability

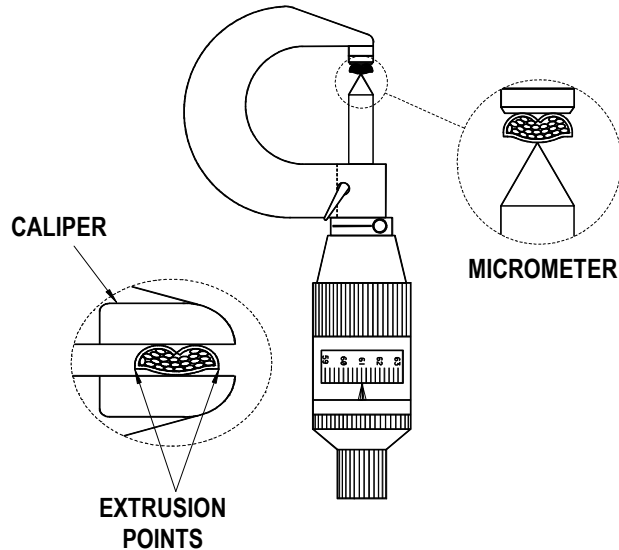

Figure A-3.1  
CRIMP HEIGHT MEASUREMENT

### A.4 Insulation Crimp

#### A.4.1 Preferred Insulation Crimp

It is preferred that the insulation crimp completely surrounds the outside diameter of the insulation. The terminal should hold on to the wire as firmly as possible without cutting through to the conductor strands. It should be noted that a preferred crimp only occurs in a small portion of the full insulation range a terminal can accommodate. A preferred insulation crimp is recommended for high vibration or movement applications.

An overlap insulation crimp is normally only developed for high vibration or movement applications where the wire diameter is near the lower terminal specification limit.

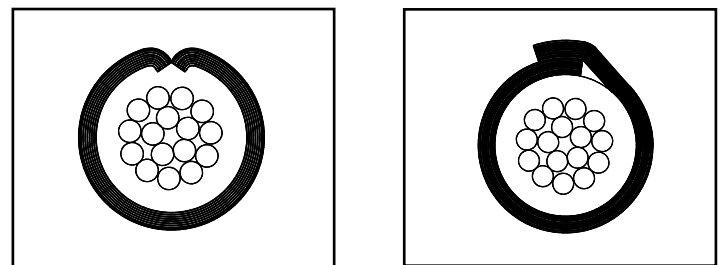

Figure A-4.1 Preferred Insulation Crimp

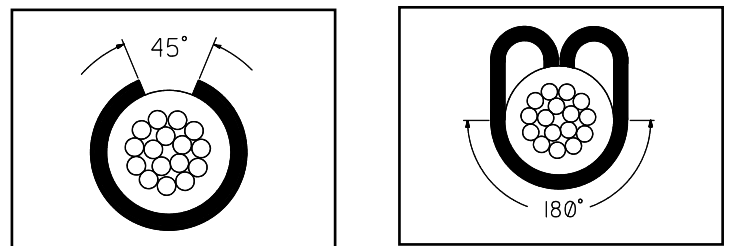

Figure A-4.2 Acceptable Insulation Crimp

#### A.4.2 Acceptable Insulation Crimp

A terminal is normally specified to cover a wide range of insulation wall thickness over a range of wire sizes. Within this specified range, an insulation crimp may not completely surround the wire or fully hold the full diameter of the wire. This condition will still give an acceptable insulation crimp for most applications.

- a) A large insulation crimp should firmly grip at least 88% of the wire.
- b) A smaller insulation crimp should firmly grip at least 50% of the wire and firmly hold the top of the wire.

**A.4.3 Marginal Insulation Crimp**

An insulation diameter near the maximum and minimum specification of a terminal may cover less than what is normally considered acceptable. These strain reliefs should only be used on applications that have low vibration or movement.

- a) Troubleshooting of marginal insulation crimp that covers in case of less than 88% of a large insulation diameter.

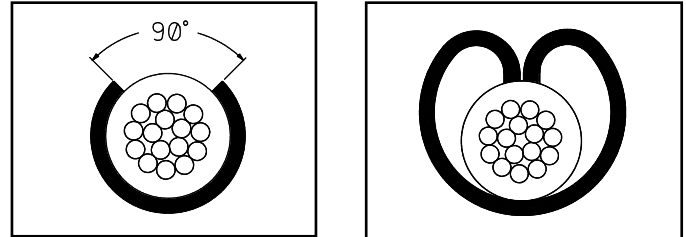

Figure A-4.3 Marginal Insulation Crimp

**Cause:** Not enough terminal grip length.

- Solution:**
- 1) Evaluate if the same terminal is available in a different wire range.
  - 2) Try crimping the wire one setting tighter. This will embed the terminal more into the insulation. The insulation wall thickness is normally enough; therefore cutting strands is not a worry. Terminal insulation grips kicking back away from the terminal or slight insulation bulging may be noticed. Evaluate the terminal loaded into housing for acceptability

- b) An insulation crimp that covers less than 50% of a small insulation diameter.

**Cause:** Too much terminal grip.

- Solution:**
- 1) Find out if the same terminal is available in a different wire range.
  - 2) Find out if overlap crimp tooling is available.

**A.4.4 Marginal Insulation Crimp**

For insulation diameters that are small, or for thin-walled insulations, a

loose crimp ensures no strand damage and offers insulation containment. Insulation crimps that pierce through the insulation will offer more strain relief. In some cases insulation terminal grips will push the strands to the side. Yet, there is always the possibility that a wire strand could be nicked. In severe cases, a wire strand may be cut. Careful application evaluation is needed for both of these cases.

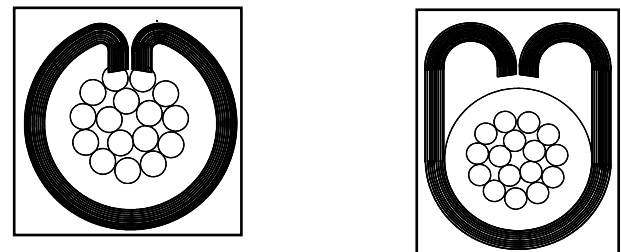

Figure A-4.4 Marginal Insulation Crimp

- Cause:**
- 1) Crimp tooling adjustment.
  - 2) Wire diameter variability.

## A.5 Pull Force Testing

### A.5.1 Pull Force Procedure

Wire connectors and soldering lugs for use with copper conductors. (Per UL486A November 15, 2003) UL Section 12 Pullout Test.

12.1 The connectors subjected to the static heating test or secureness test shall be subjected to a direct pull of the value specified for one minute. Only those connectors that have been subjected to the secureness test are to be subjected to the pullout test. The connector is acceptable if it does not become separated from the conductor or conductors after completion of the test.

12.2 For an insulated connector in which the insulation is assembled to the connector during installation, the test should be conducted with the insulation in place if it is always supplied with the connector by the manufacturer. Otherwise, the test should be conducted without the insulation assembled to the connector. Breaking or tearing of the insulation of an insulated connector is acceptable in the pullout test. The pull is to be exerted by means of a tension testing machine or equivalent, so that there will be no sudden application of force or jerking during the test.

The following is the procedure Molex uses for the qualification of pull force:

1. Cut wire length approximately 150mm (6.0") long.
2. Strip one end to 13mm (.50"), or long enough so no wire insulation is under the insulation grip.
3. Terminate the appropriate terminal to the wire to the nominal crimp height.
4. Visually inspect the termination for bell mouth, wire brush, and cut strands.
5. Set pull tester to 25.4mm (1.0") per minute. For most applications, a higher rate will not have a significant impact on the data. Verify higher pull rates with data taken at 25.4mm (1.0") per minute.
6. Knot the non-terminated end of the wire.
7. Regardless of pull tester type, both wire and terminated end must be securely clamped. (Note: When clamping the terminated end, do not clamp the conductor crimp.)
8. Activate pull test.
9. Record a minimum of 25 readings of maximum pull force. After the application has been qualified, a minimum of 5 pull force measurements should be done to confirm each setup.
10. Compare lowest reading to minimum pull force specification.

### A.5.2 Pull Test Problems

#### A.5.2.1 Wire breaks before conductor grip. Pull force low

##### Material Evaluation

**Cause:** Wire material properties, and/or coatings.

**Solution:** Test non-terminated wire for breaking strength. Change wire, if necessary.

##### Stripping Evaluation

**Cause:** Cut or nicked strands from stripping operation.

- 1) Wire being manually stripped.
- 2) Poor automatic stripping cutoff.
- 3) Worn strip tooling.

**Solution:** 1) Switch to semiautomatic or automatic wire stripping machine.  
2) Correct stripping machine setup.

#### A.5.2.2 Wire pulls out of conductor grip, crimp height good

##### Material Evaluation

**Cause:** 1) Terminal material thickness too small.

Test Values For Pullout Test UL486A			
Conductor Size		Pullout Force	
AWG	mm <sup>2</sup>	N	LBF
30	0.05	6.7	1.5
28	0.08	8.9	2
26	0.13	13.4	3
24	0.20	22.3	5
22	0.324	35.6	8
20	0.519	57.9	13
18	0.823	89.0	20
16	1.31	133.5	30
14	2.08	222.6	50
12	3.31	311.5	70
10	5.261	356.0	80
9	8.367	400.5	90

- 2) Terminal serration depth/form wrong.
- 3) Terminal plating thickness wrong.
- 4) Gold plating application.

**Solution:** 1) Evaluate a new terminal.  
2) Or Contact terminal manufacturer.  
3) Evaluate selective Gold application.

**Stripping Evaluation**

**Cause:** Wrong strip length, poor conductor brush.

**Solution:** Adjust strip length.

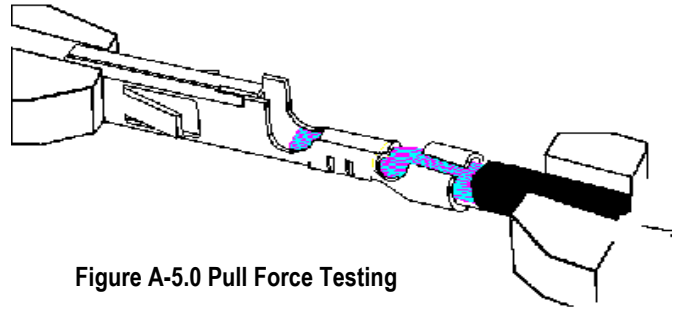

Figure A-5.0 Pull Force Testing

## Appendix B

### Statistical Process Control (Summary)

B.1 Crimp Process Control

B.2 Process Capability

B.3 Production

## B.1 Crimp Process Control

The crimp process is the interaction of a terminal, wire, tooling, personnel, methods and procedures, and environmental attributes that, when controlled, produce a quality termination. Quality control is an important aspect of quality crimping. It should not take excessive setup or inspection time to implement, and can save a harness manufacturer thousands of dollars in potential rework or re-manufacturing.

The key to quality is to target nominal specifications while continuously reducing variability. Achieving target is determined by the adjustability of the tooling. The FineAdjust applicator allows crimp height adjustment to .005mm (.0002") of target.

Variability is the slight changes that occur from crimp to crimp. There are two types of variability, common and special. Common sources of variation are those causes that affect the process uniformly, and are created from numerous small sources. Common variability is inherent tolerances within a reel of wire or terminals. In addition, common variability is created by the natural tolerances of the stripping and crimping machines. Reduction of variability at the common level normally has to come from changes at the wire, terminal, and tooling manufacturer.

The second source of variability is referred to as special cause. Unlike common cause, special sources of variation occur irregularly and unpredictably. Without checks throughout a run, a tool becoming loose after the first hundred crimps, or a damaged tool from a jam, may be undetected until thousands of crimps are made.

This section assumes that crimp height is being measured with a resolution of .0025 mm (.0001"), and pull force is measured with a resolution of 1 N (.25 lbf).

## B.2 Process Capability

Molex qualifies each FineAdjust Applicator design for pull force and crimp height.

This qualification is performed on a common wire stranding, and is targeted at 2.0 C<sub>pk</sub>. Before a new crimping tool is put in production, it is recommended that the customer using their specific wire in their process should do a capability study. A capability study is based on the assumption of a normal distribution (bell-type curve). It provides an estimate on the probability of a measurement being outside of specification.

C <sub>pk</sub>	+/- Sigma	% Yield	PPM
0.67	2	95.45	45,500
1	3	99.73	2,699
1.33	4	99.99	63
1.67	5	99.99+	0.57
2	6	99.99++	0

PPM - Parts per million – number of potential defects per million crimps produced.

A minimum of a 25-piece sample should be run off the crimping process. The average and standard deviation should be calculated for each specification.

A capability index (C<sub>p</sub>) is defined by the formula below. C<sub>p</sub> may range in value from 0 to infinity, with a larger value indicating a more capable process. A value greater than (>) 1.33 is normally considered acceptable.

$$\frac{\text{Tolerance}}{6 \times \text{Standard Deviation}}$$

The C<sub>pk</sub> index indicates whether the process will produce units within the tolerance limits. C<sub>pk</sub> has a value equal to C<sub>p</sub> if the process is centered on the mean of specification; if C<sub>pk</sub> is negative, the process mean is outside the specification limits; if C<sub>pk</sub> is between 0 and 1 then some of the 6 sigma spread falls outside the tolerance limits. If C<sub>pk</sub> is larger than 1, the 6 sigma spread is completely within the tolerance limits. C<sub>pk</sub> is calculated with the lesser of the following formulas:

$$\frac{(\text{USL} - \text{MEAN})}{3 \times \text{Standard Deviation}} \quad \frac{(\text{LSL} - \text{MEAN})}{3 \times \text{Standard Deviation}}$$

USL = Upper Specification Limit, LSL = Lower Specification Limit

Six sigma is a goal of many companies because it represents virtually zero defects. The ability of a company to achieve a six-sigma level is dependent on the amount of common variability in their process. Hand stripping of the wire will produce more variability than a stripping machine.

A crimping hand tool will produce more variability than a press and die set. Bench terminations will produce more variability than a wire-processing machine.

A portion of the variability in crimping will come from what instruments are used to measure the parts and the ability of an operator to repeat the measurement. A crimp micrometer will measure more accurately than a dial caliper. An automatic pull force system will measure

better than a hook type scale. It is important that the measurement gauge has enough resolution. Two operators may measure the same part differently, or the same operator may measure the part different when using two types of gauges. A gauge capability study is recommended to identify what part of the variability is coming from measurement error. Micro-terminals crimped to small wire sizes need a tight crimp height range to maintain pull force. The variability from measurement error can keep  $C_{pk}$ s low.

The capability of the crimping tools should be re-confirmed if the production data is significantly different from the capability study.

### B.3 Production

Once the level of capability is established, the tool is ready for production.

Many harness manufacturers run only a few hundred or few thousand wires at one time. In this case, it is not practical or economical to run a twenty-five-piece capability with every set-up.

#### Setup Confirmation

After the setup of the crimping process, crimp five terminals with a loose insulation crimp. Visually inspect or measure bell mouth, cut-off tab length, conductor brush, insulation position, and conductor crimp height. Make the appropriate adjustments to the machine. (Refer to trouble shooting sections if needed). After all adjustments have been made, crimp five more samples for pull force evaluation. The pull force is a good indicator for cut or nicked strands, short conductor brush, small bell mouth, or incorrect crimp height. Calculate the average. Compare the average and minimum reading with the capability study data.

After the pull force has been confirmed, set the insulation crimp to the appropriate setting. Re-check crimp height and make the proper adjustments if necessary.

Crimp five more samples and document the average crimp height, the maximum reading, and the minimum reading.

The range is considered the maximum reading minus the minimum reading. With a crimp micrometer and an experienced operator, the range for crimp terminations is normally only a few ten thousandths of an inch. This data becomes the first point on the control chart.

### Production (Control Charting)

It should be normal procedure for the operator to visually fan each bundle of crimped wires and visually check bell mouth, conductor brush, insulation position, and cut-off tab length and insulation crimp height. Crimp height should be checked throughout the run. The frequency of each check is determined by the risk you wish to take for scraping parts. A check every 250 to 500 parts is recommended.

#### Control Charting

Crimp height is normally control charted since it is a quick nondestructive measurement and is critical for the electrical reliability of the termination.

There are three primary purposes for control charting. First, the numbers of setup samples are normally small, and its statistical value is limited. Second, since special cause effects on a process are irregular and unpredictable, it is necessary to have a means of catching changes in the process as soon as they occur. This prevents thousands of terminations from being scrapped after the run is over. Third and most important, this data is necessary to assess and improve the crimp process.

Once the tooling process is set-up and the wire size is not changing, keep one control chart for wire color changes, wire length changes, terminal material changes, or setup adjustments. Record the data point on the chart before a crimp height adjustment is made. If data is recorded after each adjustment, the process most likely will assume control and provide little data for improving the process. Write as many notes on the chart as possible.

The only truly effective and economically sensible manner of managing a manufacturing process is to understand, monitor, and reduce sources of variability inherent to the process itself. Every minute the process is down for setup or adjustment is unproductive.

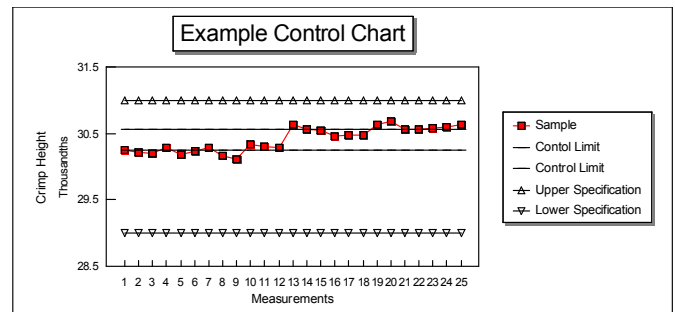

**X and R Chart**  
**Control Limit for sample of 5 = Avg (Avg. of 5 readings)**  
**± .577 x Avg (Ranges)**



What does this sample chart tell us? A process shift occurred between measurement 12 and 13. This type of shift could occur due to a change in wire, a change in terminal lots, a jam in the machine that damaged the tooling, a change in operators, or an adjustment to the insulation crimp. Since the measurements are still within specification, would you stop production to adjust crimp height?

A shift in the process due to a change in material may arrant a crimp height adjustment. A shift after a jam would not indicate an adjustment, but a close evaluation of the tooling. A shift in the process between operators would not indicate an adjustment, but an evaluation of measurement capability.

The idea of the control chart is to identify what caused the shift to justify if an adjustment to the process is warranted.

The FineAdjust Applicator is extremely easy to adjust. It is just as important to chart and document process control with the FineAdjust applicator.

If the process shift is due to a jam or a change in operators, more evaluation may be necessary than an adjustment.

Many crimping processes have been producing product within specification for decades. Today, with statistical process control, the philosophy of quality is being within specification is being replaced by being on target with continuous reduction in variability. Control charting is a tool that truly allows a company to understand their process.

**ATTENTION**

Reference must always be made to product application / crimp specification to determine crimp parameters.

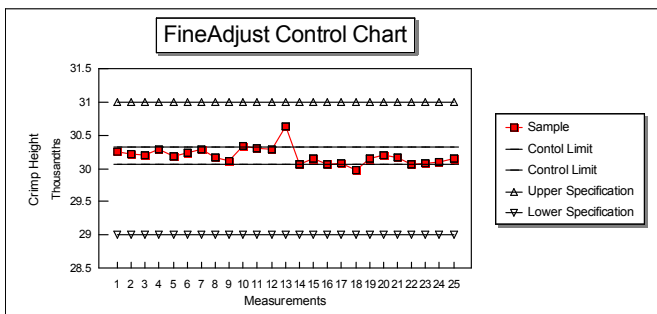



## Appendix C

### Options

1 Oiler

<b>Terminal Oiler For FineAdjust and Mini-Mac Applicators</b>		
	<b>Application Tooling Information Sheet</b>	<b>Order No. 63890-0719</b>

**Terminal Oiler**

To install a Terminal Oiler (Order No. 63890-0719) to any FineAdjust or Mini-Mac Applicator, use the following procedure.

1. Remove lid assembly from the oiler jar.
2. Remove upper oiler nut from lid assembly.
3. Place oiler mtg. bracket over tube, replace upper nut, and tighten securely.
4. Place lid assembly with mtg. bracket on the oiler jar and turn until hand tight. Do not over tighten.
5. Mount terminal oiler assembly with bracket on the frame of the FineAdjust or Mini-Mac Applicator.
6. Recommended lubricant oil:

Product Name: Transdraw B-19  
Vendor: Mid-Town Petroleum  
 9707 South 76<sup>th</sup> Avenue  
 Bridgeview, IL 60455  
 Toll-Free: 877-255-3533  
 Direct: 708-599-8700  
 Fax: 708-599-1040  
 E-mail: sales@midtownoil.com  
 www.midtownoil.com  
 www.precisionlubricantsinc.com

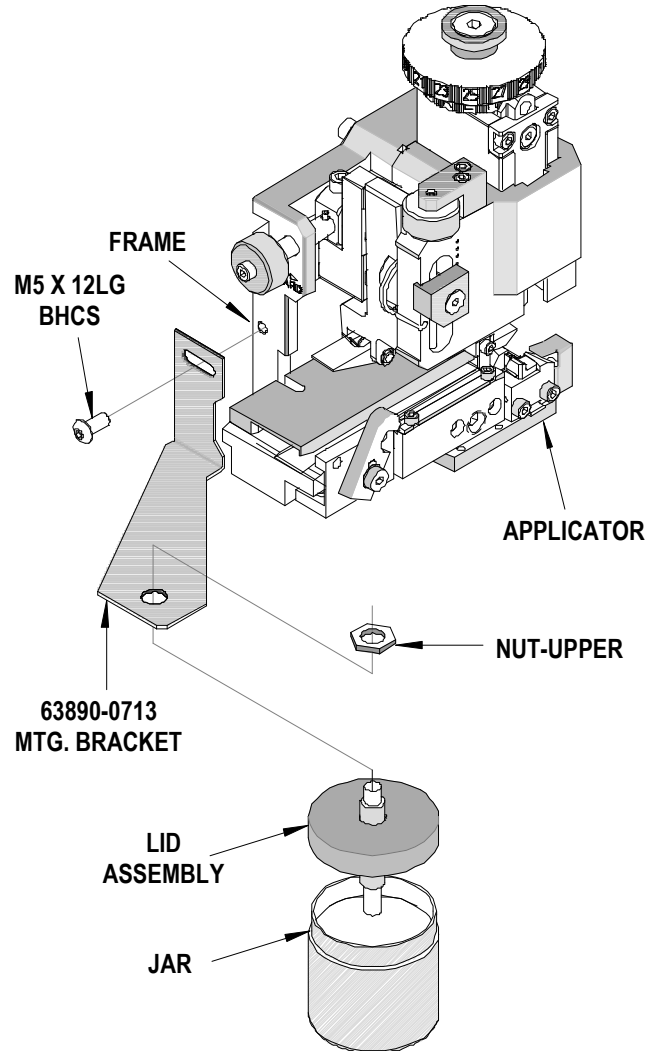

7. For replacement wicks use part no. 63890-0727 (package of 25).

Visit our Web site at <http://www.molex.com>