

<b>SPECIFICATION CONTROL DRAWING</b>	<b>7024B0131</b>
--------------------------------------	------------------

<b>CHEMINAX</b>	70 OHM, AWG 24, 19 STRANDS OF AWG 36, THREE CONDUCTOR CABLE	Date	9-2-11
		Revision	A

THIS SPECIFICATION SHEET FORMS A PART OF THE LATEST ISSUE OF RAYCHEM SPECIFICATION 1200.

<b>CONSTRUCTION DETAILS</b>	<b>ELECTRICAL CHARACTERISTICS</b>
-----------------------------	-----------------------------------

DIMENSIONS ARE NOMINAL VALUES IN INCHES UNLESS OTHERWISE DESIGNATED.

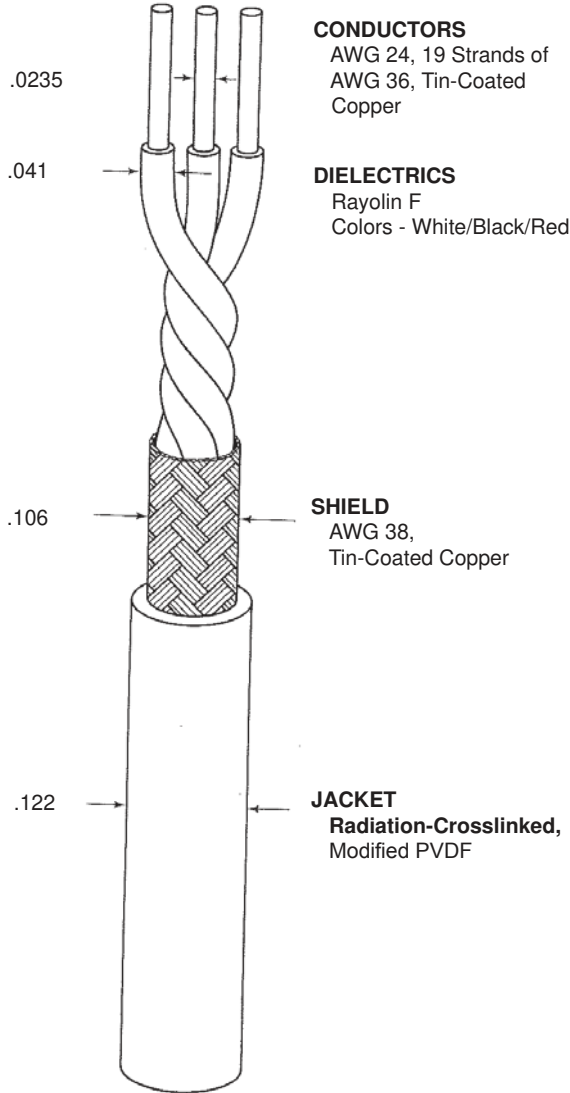

**CONDUCTORS**  
AWG 24, 19 Strands of  
AWG 36, Tin-Coated  
Copper

**DIELECTRICS**  
Rayolin F  
Colors - White/Black/Red

**SHIELD**  
AWG 38,  
Tin-Coated Copper

**JACKET**  
Radiation-Crosslinked,  
Modified PVDF

CHARACTERISTIC IMPEDANCE	70 ± 10 ohms, Method C at 1 MHz
MUTUAL CAPACITANCE	24.4 pF/ft. (nominal)
VELOCITY OF PROPAGATION	66% (nominal)

**ADDITIONAL REQUIREMENTS**

**ELECTRICAL**

CONDUCTOR RESISTANCE	25.7 ohms/1000 ft. (nominal)
INSULATION RESISTANCE	10,000 megohms (minimum) for 1000 ft.
JACKET FLAWS	
SPARK TEST	1.0 kV (rms)
IMPULSE TEST	6.0 kV (peak)
VOLTAGE WITHSTAND (DIELECTRIC)	1000 volts (rms) (minimum)

**ENVIRONMENTAL**

FLAMMABILITY	Method B
HEAT SHOCK	225°C
LOW TEMPERATURE-COLD BEND	-55°C/3.25 inch mandrel
VOLTAGE WITHSTAND (Post Environmental)	1000 volts (rms), 1 minute

**PHYSICAL**

INSULATION (DIELECTRIC) (Prior to Cabling)	
ELONGATION	200% (minimum)
TENSILE STRENGTH	1800 lbf/in <sup>2</sup> (minimum)
JACKET	
ELONGATION	200% (minimum)
TENSILE STRENGTH	4000 lbf/in <sup>2</sup> (minimum)
JACKET THICKNESS	.008 inch (nominal)
SHIELD COVERAGE	90% (minimum)

WEIGHT	12.4 lbs/1000 ft. (nominal)
--------	-----------------------------

Outer jacket color will be white (designated by a "-9" appended to the part number, e.g. 7024B0131-9) unless otherwise specified.

Designate outer jacket color with a dash number in accordance with MIL-STD-681. Other codes and suffixes may be added to the part number, as necessary, to capture any additional requirements imposed by the purchase order.

Users should evaluate the suitability of this product for their application. Specifications are subject to change without notice. Tyco Electronics Corporation also reserves the right to make changes in materials or processing, which do not affect compliance with any specification, without notification to Buyer.



Raychem Wire & Cable  
501 Oakside Avenue  
Redwood City, California 94063-3800  
1-800-227-8816 Fax: 1-650-361-6297

THIS SPECIFICATION SHEET TAKES PRECEDENCE OVER DOCUMENTS REFERENCED HEREIN. REFERENCED DOCUMENTS SHALL BE OF THE ISSUE IN EFFECT ON DATE OF INVITATION FOR BID.