

## ISL3332, ISL3333

3.3V, ±15kV ESD Protected, Two Port, Dual Protocol (RS-232/RS-485) Transceivers

FN6362  
Rev 1.00  
Jan 21, 2021

The ISL3332, ISL3333 are two port interface ICs where each port can be independently configured as a single RS-485/422 transceiver, or as a dual (2 Tx, 2 Rx) RS-232 transceiver. With both ports set to the same mode, two RS-485/RS-422 transceivers, or four RS-232 transceivers are available.

If either port is in RS-232 mode, the onboard charge pump generates RS-232 compliant ±5V Tx output levels from a single V<sub>CC</sub> supply as low as 3.15V. The transceivers are RS-232 compliant, with the Rx inputs handling up to ±25V.

In RS-485 mode, the transceivers support both the RS-485 and RS-422 differential communication standards. The receivers feature “full fail-safe” operation, so the Rx outputs remain in a high state if the inputs are open or shorted together. The transmitters support up to three data rates, two of which are slew rate limited for problem free communications. The charge pump disables when both ports are in RS-485 mode, thereby saving power, minimizing noise, and eliminating the charge pump capacitors.

Both RS-232 and RS-485 modes feature loopback and shutdown functions. Loopback internally connects the Tx outputs to the corresponding Rx input, to facilitate board level self test implementation. The outputs remain connected to the loads during loopback, so connection problems (e.g., shorted connectors or cables) can be detected. Shutdown mode disables the Tx and Rx outputs, disables the charge pumps, and places the IC in a low current (35µA) mode.

The ISL3333 is a QFN packaged device that includes two additional user selectable, lower speed and edge rate options for EMI sensitive designs, or to allow longer bus lengths. It also features a logic supply pin (V<sub>L</sub>) that sets the V<sub>OH</sub> level of logic outputs, and the switching points of logic inputs, to be compatible with another supply voltage in mixed voltage systems. The QFN also adds RS-232 mode Tx EN pins (DEN), and active low Rx enable pins ( $\overline{RXEN}$ ) to increase design flexibility. In RS-485 applications, active low Rx enable pins allow Tx/Rx direction control, via a single signal per port, by connecting the corresponding DE and  $\overline{RXEN}$  pins together.

For a single port version of these devices, please see the ISL3330, ISL3331 data sheet.

### Features

- ±15kV (HBM) ESD Protected Bus Pins (RS-232 or RS-485)
- Operates From a Single 3.3V Supply
- Two Independent Ports, Each User Selectable for RS-232 (2 Transceivers) or RS-485/RS-422 (1 Transceiver)
- True Flow-Through Pinouts Simplify Board Layouts
- Pb-free (RoHS compliant)
- Full Failsafe (Open/Short) Rx in RS-485/422 Mode
- Loopback Mode Facilitates Board Self Test Functions
- User Selectable RS-485 Data Rates (ISL3333 Only)
  - Fast Speed . . . . . 20Mbps
  - Slew Rate Limited. . . . . 460kbps
  - Slew Rate Limited. . . . . 115kbps
- Fast RS-232 Data Rate . . . . . Up to 400kbps
- RS-232 Tx and Rx Enable Pins (ISL3333 Only)
- Small Charge Pump Caps . . . . . 4 x 0.1µF
- Low Current Shutdown Mode. . . . . 35µA
- QFN Package Saves Board Space (ISL3333 Only)
- Logic Supply Pin (V<sub>L</sub>) Eases Operation in Mixed Supply Systems (ISL3333 Only)

### Applications

- Gaming Applications (such as Slot Machines)
- Single Board Computers
- Factory Automation
- Security Networks
- Industrial/Process Control Networks
- Level Translators (such as RS-232 to RS-422)
- Point of Sale Equipment
- Dual Channel RS-485 Interfaces

TABLE 1. SUMMARY OF FEATURES

| PART NUMBER | NO. OF PORTS | PACKAGE OPTIONS     | RS-485 DATA RATE (bps) | RS-232 DATA RATE (kbps) | V <sub>L</sub> PIN? | RS-232 Tx ENABLE? | ACTIVE H or L Rx ENABLE? | LOW POWER SHUTDOWN? |
|-------------|--------------|---------------------|------------------------|-------------------------|---------------------|-------------------|--------------------------|---------------------|
| ISL3332     | 2            | 28 Ld SSOP          | 20M                    | 400                     | NO                  | NO                | NONE                     | YES                 |
| ISL3333     | 2            | 40 Ld QFN (6 x 6mm) | 20M, 460k, 115k        | 400                     | YES                 | YES               | L                        | YES                 |

## Ordering Information

| PART NUMBER<br>(Notes 2, 3) | PART MARKING | TEMP. RANGE<br>(°C) | TAPE AND REEL<br>(Units) (Note 1) | PACKAGE<br>(RoHS Compliant) | PKG. DWG. # |
|-----------------------------|--------------|---------------------|-----------------------------------|-----------------------------|-------------|
| ISL3332IAZ                  | 3332 IAZ     | -40 to +85          | -                                 | 28 Ld SSOP                  | M28.209     |
| ISL3332IAZ-T                | 3332 IAZ     | -40 to +85          | 1k                                | 28 Ld SSOP                  | M28.209     |
| ISL3333IRZ                  | 3333 IRZ     | -40 to +85          | -                                 | 40 Ld QFN                   | L40.6x6     |
| ISL3333IRZ-T                | 3333 IRZ     | -40 to +85          | 4k                                | 40 Ld QFN                   | L40.6x6     |
| ISL3333IRZ-T7A              | 3333 IRZ     | -40 to +85          | 250                               | 40 Ld QFN                   | L40.6x6     |

NOTES:

- See [TB347](#) for details about reel specifications.
- These Pb-free plastic packaged products employ special Pb-free material sets, molding compounds/die attach materials, and 100% matte tin plate plus anneal (e3 termination finish, which is RoHS compliant and compatible with both SnPb and Pb-free soldering operations). Pb-free products are MSL classified at Pb-free peak reflow temperatures that meet or exceed the Pb-free requirements of IPC/JEDEC J STD-020.
- For Moisture Sensitivity Level (MSL), see the [ISL3332](#), [ISL3333](#) device pages. For more information about MSL, see [TB363](#).

## Pinouts

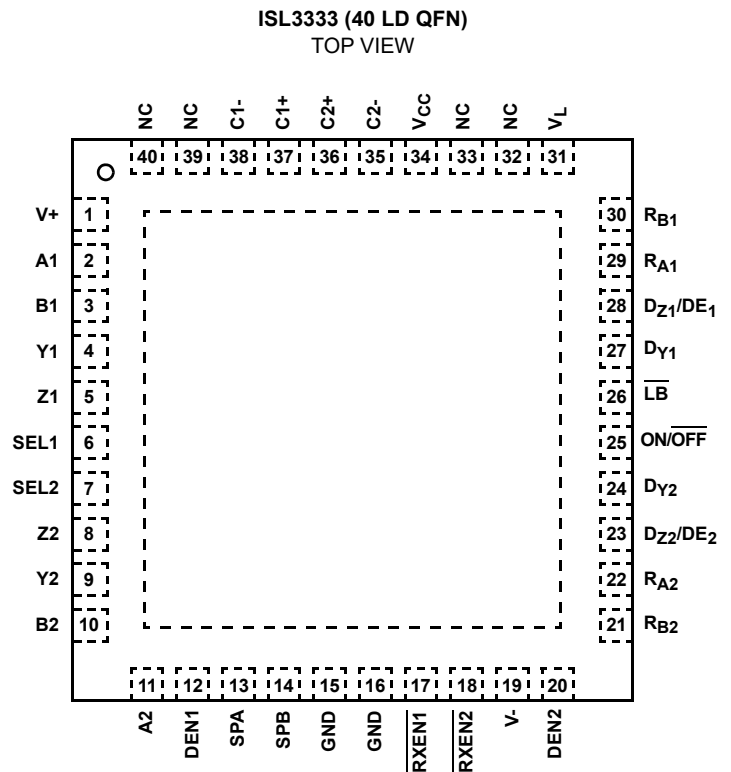
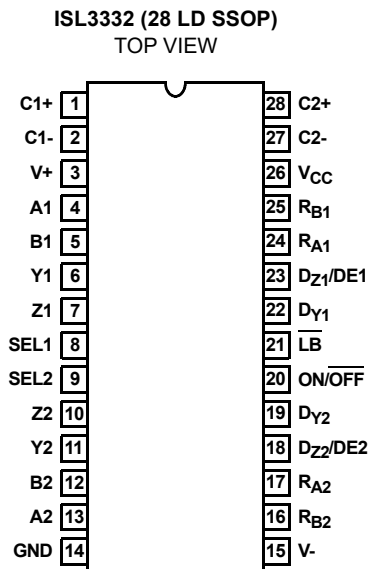

TABLE 2. ISL3332 FUNCTION TABLE

| INPUTS    |        |           | RECEIVER OUTPUTS |                | DRIVER OUTPUTS |        | CHARGE PUMPS<br>(Note 4) | MODE     |
|-----------|--------|-----------|------------------|----------------|----------------|--------|--------------------------|----------|
| SEL1 or 2 | ON/OFF | DE 1 or 2 | R <sub>A</sub>   | R <sub>B</sub> | Y              | Z      |                          |          |
| 0         | 1      | N.A.      | ON               | ON             | ON             | ON     | ON                       | RS-232   |
| X         | 0      | X         | High-Z           | High-Z         | High-Z         | High-Z | OFF                      | Shutdown |
| 1         | 1      | 0         | ON               | High-Z *       | High-Z         | High-Z | OFF                      | RS-485   |
| 1         | 1      | 1         | ON               | High-Z *       | ON             | ON     | OFF                      | RS-485   |

NOTE:

4. Charge pumps are off if SEL1 = SEL2 = 1, or if ON/OFF = 0. If ON = 1, and either port is programmed for RS-232 mode, then the charge pumps are on.

**ISL3332 Truth Tables** (FOR EACH PORT)

| RS-232 TRANSMITTING MODE |        |                |                |         |        |
|--------------------------|--------|----------------|----------------|---------|--------|
| INPUTS                   |        |                |                | OUTPUTS |        |
| SEL1 or 2                | ON/OFF | D <sub>Y</sub> | D <sub>Z</sub> | Y       | Z      |
| 0                        | 1      | 0              | 0              | 1       | 1      |
| 0                        | 1      | 0              | 1              | 1       | 0      |
| 0                        | 1      | 1              | 0              | 0       | 1      |
| 0                        | 1      | 1              | 1              | 0       | 0      |
| 0                        | 0      | X              | X              | High-Z  | High-Z |

| RS-485 TRANSMITTING MODE |        |          |                |         |        |
|--------------------------|--------|----------|----------------|---------|--------|
| INPUTS                   |        |          |                | OUTPUTS |        |
| SEL1 or 2                | ON/OFF | DE1 or 2 | D <sub>Y</sub> | Y       | Z      |
| 1                        | 1      | 1        | 0              | 1       | 0      |
| 1                        | 1      | 1        | 1              | 0       | 1      |
| 1                        | 1      | 0        | X              | High-Z  | High-Z |
| 1                        | 0      | X        | X              | High-Z  | High-Z |

| RS-232 RECEIVING MODE |        |      |      |                |                |
|-----------------------|--------|------|------|----------------|----------------|
| INPUTS                |        |      |      | OUTPUT         |                |
| SEL1 or 2             | ON/OFF | A    | B    | R <sub>A</sub> | R <sub>B</sub> |
| 0                     | 1      | 0    | 0    | 1              | 1              |
| 0                     | 1      | 0    | 1    | 1              | 0              |
| 0                     | 1      | 1    | 0    | 0              | 1              |
| 0                     | 1      | 1    | 1    | 0              | 0              |
| 0                     | 1      | Open | Open | 1              | 1              |
| 0                     | 0      | X    | X    | High-Z         | High-Z         |

| RS-485 RECEIVING MODE |        |                          |  |                |                  |
|-----------------------|--------|--------------------------|--|----------------|------------------|
| INPUTS                |        |                          |  | OUTPUT         |                  |
| SEL1 or 2             | ON/OFF | B-A                      |  | R <sub>A</sub> | R <sub>B</sub> * |
| 1                     | 1      | ≥ -40mV                  |  | 1              | High-Z           |
| 1                     | 1      | ≤ -200mV                 |  | 0              | High-Z           |
| 1                     | 1      | Open or Shorted together |  | 1              | High-Z           |
| 1                     | 0      | X                        |  | High-Z         | High-Z           |

\* Internally pulled high through a 40kΩ resistor.

TABLE 3. ISL3333 FUNCTION TABLE

| INPUTS    |        |     |     |             |            |           | RECEIVER OUTPUTS |                | DRIVER OUTPUTS |        | CHARGE PUMPS (Note 5) | DRIVER DATA RATE (Mbps) | MODE     |
|-----------|--------|-----|-----|-------------|------------|-----------|------------------|----------------|----------------|--------|-----------------------|-------------------------|----------|
| SEL1 or 2 | ON/OFF | SPA | SPB | RXEN 1 or 2 | DEN 1 or 2 | DE 1 or 2 | R <sub>A</sub>   | R <sub>B</sub> | Y              | Z      |                       |                         |          |
| 0         | 1      | X   | X   | 0           | 0          | N.A.      | ON               | ON             | High-Z         | High-Z | ON                    | 0.46                    | RS-232   |
| 0         | 1      | X   | X   | 0           | 1          | N.A.      | ON               | ON             | ON             | ON     | ON                    | 0.46                    | RS-232   |
| 0         | 1      | X   | X   | 1           | 0          | N.A.      | High-Z           | High-Z         | High-Z         | High-Z | ON                    | 0.46                    | RS-232   |
| 0         | 1      | X   | X   | 1           | 1          | N.A.      | High-Z           | High-Z         | ON             | ON     | ON                    | 0.46                    | RS-232   |
| X         | 0      | X   | X   | X           | X          | X         | High-Z           | High-Z         | High-Z         | High-Z | OFF                   | N.A.                    | Shutdown |
| 1         | 1      | X   | X   | 0           | N.A.       | 0         | ON               | High-Z *       | High-Z         | High-Z | OFF                   | N.A.                    | RS-485   |
| 1         | 1      | 0   | 0   | 0           | N.A.       | 1         | ON               | High-Z *       | ON             | ON     | OFF                   | 0.46                    | RS-485   |
| 1         | 1      | 0   | 1   | 0           | N.A.       | 1         | ON               | High-Z *       | ON             | ON     | OFF                   | 0.115                   | RS-485   |
| 1         | 1      | 1   | 0   | 0           | N.A.       | 1         | ON               | High-Z *       | ON             | ON     | OFF                   | 20                      | RS-485   |
| 1         | 1      | 1   | 1   | 0           | N.A.       | 1         | ON               | High-Z *       | ON             | ON     | OFF                   | 20                      | RS-485   |
| 1         | 1      | X   | X   | 1           | N.A.       | 0         | High-Z           | High-Z *       | High-Z         | High-Z | OFF                   | N.A.                    | RS-485   |
| 1         | 1      | 0   | 0   | 1           | N.A.       | 1         | High-Z           | High-Z *       | ON             | ON     | OFF                   | 0.46                    | RS-485   |
| 1         | 1      | 0   | 1   | 1           | N.A.       | 1         | High-Z           | High-Z *       | ON             | ON     | OFF                   | 0.115                   | RS-485   |
| 1         | 1      | 1   | 0   | 1           | N.A.       | 1         | High-Z           | High-Z *       | ON             | ON     | OFF                   | 20                      | RS-485   |
| 1         | 1      | 1   | 1   | 1           | N.A.       | 1         | High-Z           | High-Z *       | ON             | ON     | OFF                   | 20                      | RS-485   |

NOTE:

5. Charge pumps are off if SEL1 = SEL2 = 1, or if ON/OFF = 0. If ON = 1, and either port is programmed for RS-232 mode, then the charge pumps are on.

**ISL3333 Truth Tables** (FOR EACH PORT)

| RS-232 TRANSMITTING MODE |        |           |                |                |         |        |
|--------------------------|--------|-----------|----------------|----------------|---------|--------|
| INPUTS                   |        |           |                |                | OUTPUTS |        |
| SEL1 or 2                | ON/OFF | DEN1 or 2 | D <sub>Y</sub> | D <sub>Z</sub> | Y       | Z      |
| 0                        | 1      | 1         | 0              | 0              | 1       | 1      |
| 0                        | 1      | 1         | 0              | 1              | 1       | 0      |
| 0                        | 1      | 1         | 1              | 0              | 0       | 1      |
| 0                        | 1      | 1         | 1              | 1              | 0       | 0      |
| 0                        | 1      | 0         | X              | X              | High-Z  | High-Z |
| 0                        | 0      | X         | X              | X              | High-Z  | High-Z |

| RS-232 RECEIVING MODE |        |             |      |      |                |                |
|-----------------------|--------|-------------|------|------|----------------|----------------|
| INPUTS                |        |             |      |      | OUTPUT         |                |
| SEL1 or 2             | ON/OFF | RXEN 1 or 2 | A    | B    | R <sub>A</sub> | R <sub>B</sub> |
| 0                     | 1      | 0           | 0    | 0    | 1              | 1              |
| 0                     | 1      | 0           | 0    | 1    | 1              | 0              |
| 0                     | 1      | 0           | 1    | 0    | 0              | 1              |
| 0                     | 1      | 0           | 1    | 1    | 0              | 0              |
| 0                     | 1      | 0           | Open | Open | 1              | 1              |
| 0                     | 1      | 1           | X    | X    | High-Z         | High-Z         |
| 0                     | 0      | X           | X    | X    | High-Z         | High-Z         |

| RS-485 TRANSMITTING MODE |        |           |     |     |                |         |        |           |
|--------------------------|--------|-----------|-----|-----|----------------|---------|--------|-----------|
| INPUTS                   |        |           |     |     |                | OUTPUTS |        | DATA RATE |
| SEL1 or 2                | ON/OFF | DE 1 or 2 | SPA | SPB | D <sub>Y</sub> | Y       | Z      | Mbps      |
| 1                        | 1      | 1         | 0   | 0   | 0/1            | 1/0     | 0/1    | 0.46      |
| 1                        | 1      | 1         | 0   | 1   | 0/1            | 1/0     | 0/1    | 0.115     |
| 1                        | 1      | 1         | 1   | X   | 0/1            | 1/0     | 0/1    | 20        |
| 1                        | 1      | 0         | X   | X   | X              | High-Z  | High-Z | N.A.      |
| 1                        | 0      | X         | X   | X   | X              | High-Z  | High-Z | N.A.      |

| RS-485 RECEIVING MODE |        |             |                          |                |                  |
|-----------------------|--------|-------------|--------------------------|----------------|------------------|
| INPUTS                |        |             |                          | OUTPUT         |                  |
| SEL1 or 2             | ON/OFF | RXEN 1 or 2 | B-A                      | R <sub>A</sub> | R <sub>B</sub> * |
| 1                     | 1      | 0           | ≥ -40mV                  | 1              | High-Z           |
| 1                     | 1      | 0           | ≤ -200mV                 | 0              | High-Z           |
| 1                     | 1      | 0           | Open or Shorted together | 1              | High-Z           |
| 1                     | 1      | 1           | X                        | High-Z         | High-Z           |
| 1                     | 0      | X           | X                        | High-Z         | High-Z           |

\* Internally pulled high through a 40kΩ resistor.

## Pin Descriptions

| PIN                        | MODE   | FUNCTION   |
|----------------------------|--------|--|
| GND                        | BOTH   | Ground connection.   |
| $\overline{\text{LB}}$     | BOTH   | Enables loopback mode when low. Internally pulled-high.  |
| NC                         | BOTH   | No Connection.   |
| $\overline{\text{ON/OFF}}$ | BOTH   | If either port is in RS-232 mode, a low on $\overline{\text{ON/OFF}}$ disables the charge pumps. In either mode, a low disables all the outputs, and places the device in low power shutdown. Internally pulled-high. ON = 1 for normal operation. |
| $\overline{\text{RXEN}}$   | BOTH   | Active low receiver output enable. The corresponding port's Rx is enabled when $\overline{\text{RXEN}}$ is low; Rx is high impedance when RXEN is high. Internally pulled low. (QFN only)  |
| SEL                        | BOTH   | Interface Mode Select input. High puts corresponding port in RS-485 Mode, while a low puts it in RS-232 Mode.  |
| V <sub>CC</sub>            | BOTH   | System power supply input (3.3V).  |
| V <sub>L</sub>             | BOTH   | Logic-Level Supply. All TTL/CMOS inputs and outputs are powered by this supply. QFN logic input pins that are externally tied high in an application, should use the V <sub>L</sub> supply for the high voltage level. (QFN only)                  |
| DEN                        | RS-232 | Active high driver output enable. The corresponding port's 232 mode drivers are enabled when DEN is high; drivers are disabled when DEN is low. Internally pulled high. (QFN only).  |
| A                          | RS-232 | Receiver input with $\pm 15\text{kV}$ ESD protection. A low on A forces R <sub>A</sub> high; A high on A forces R <sub>A</sub> low.  |
|                            | RS-485 | Inverting receiver input with $\pm 15\text{kV}$ ESD protection.  |
| B                          | RS-232 | Receiver input with $\pm 15\text{kV}$ ESD protection. A low on B forces R <sub>B</sub> high; A high on B forces R <sub>B</sub> low.  |
|                            | RS-485 | Noninverting receiver input with $\pm 15\text{kV}$ ESD protection.   |
| D <sub>Y</sub>             | RS-232 | Driver input. A low on D <sub>Y</sub> forces output Y high. Similarly, a high on D <sub>Y</sub> forces output Y low.   |
|                            | RS-485 | Driver input. A low on D <sub>Y</sub> forces output Y high and output Z low. Similarly, a high on D <sub>Y</sub> forces output Y low and output Z high.  |
| D <sub>Z</sub> / DE        | RS-232 | Driver input. A low on D <sub>Z</sub> forces output Z high. Similarly, a high on D <sub>Z</sub> forces output Z low.   |
|                            | RS-485 | Driver output enable (DE). The driver outputs, Y and Z, are enabled by bringing DE high. They are high impedance when DE is low. Internally pulled high when port selected for RS-485 mode.  |
| R <sub>A</sub>             | RS-232 | Receiver output.   |
|                            | RS-485 | Receiver output: If B > A by at least -40mV, R <sub>A</sub> is high; If B < A by -200mV or more, R <sub>A</sub> is low; R <sub>A</sub> = High if A and B are unconnected (floating) or shorted together (i.e., full fail-safe).                    |
| R <sub>B</sub>             | RS-232 | Receiver output.   |
|                            | RS-485 | Not used. Internally pulled-high, and unaffected by $\overline{\text{RXEN}}$ .   |
| Y                          | RS-232 | Driver output with $\pm 15\text{kV}$ ESD protection.   |
|                            | RS-485 | Inverting driver output with $\pm 15\text{kV}$ ESD protection.   |
| Z                          | RS-232 | Driver output with $\pm 15\text{kV}$ ESD protection.   |
|                            | RS-485 | Noninverting driver output with $\pm 15\text{kV}$ ESD protection.  |
| SP                         | RS-485 | Speed control. Internally pulled-high. (QFN only)  |
| C1+                        | RS-232 | External capacitor (voltage doubler) is connected to this lead. Not needed if both ports in RS-485 Mode.   |
| C1-                        | RS-232 | External capacitor (voltage doubler) is connected to this lead. Not needed if both ports in RS-485 Mode.   |
| C2+                        | RS-232 | External capacitor (voltage inverter) is connected to this lead. Not needed if both ports in RS-485 Mode.  |
| C2-                        | RS-232 | External capacitor (voltage inverter) is connected to this lead. Not needed if both ports in RS-485 Mode.  |
| V+                         | RS-232 | Internally generated positive RS-232 transmitter supply (+5.5V). C3 not needed if both ports in RS-485 Mode.   |
| V-                         | RS-232 | Internally generated negative RS-232 transmitter supply (-5.5V). C4 not needed if both ports in RS-485 Mode.   |

## Typical Operating Circuits

RS-232 MODE WITHOUT LOOPBACK

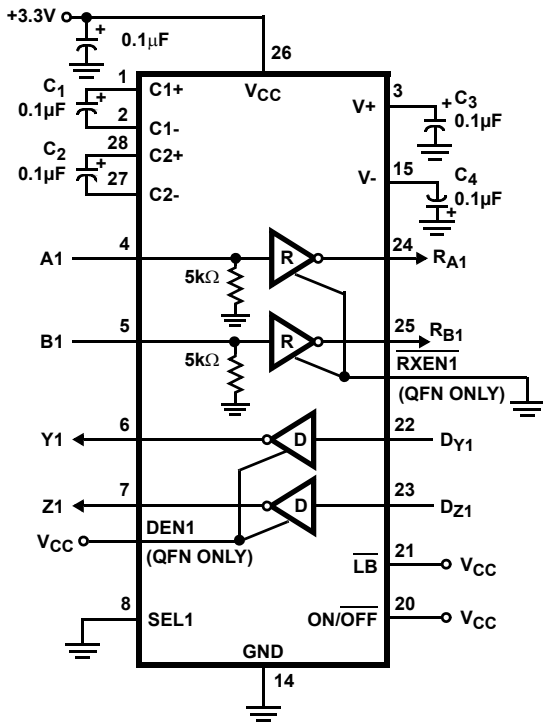

NOTE: PINOUT FOR SSOP  
SAME FOR PORT 2.

RS-232 MODE WITH LOOPBACK

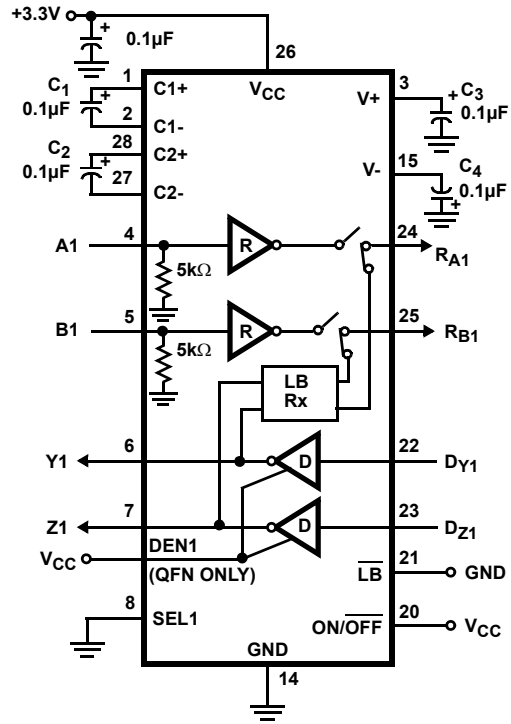

NOTE: PINOUT FOR SSOP  
SAME FOR PORT 2.

RS-485 MODE WITHOUT LOOPBACK

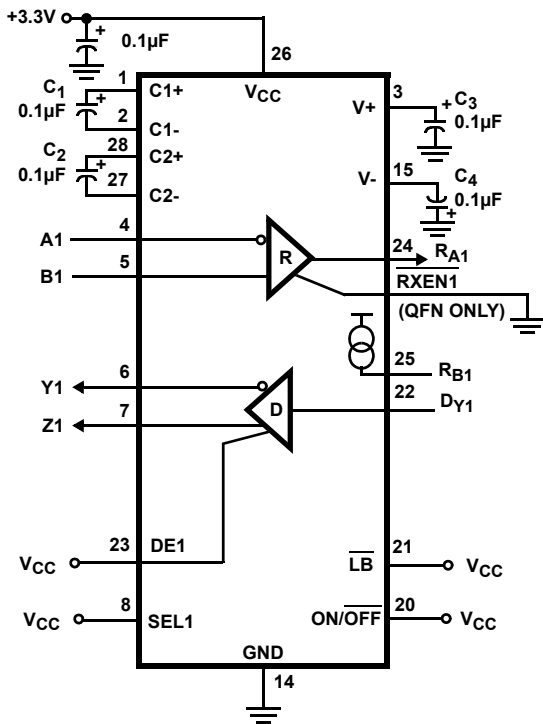

NOTE: PINOUT FOR SSOP  
SAME FOR PORT 2.

RS-485 MODE WITH LOOPBACK

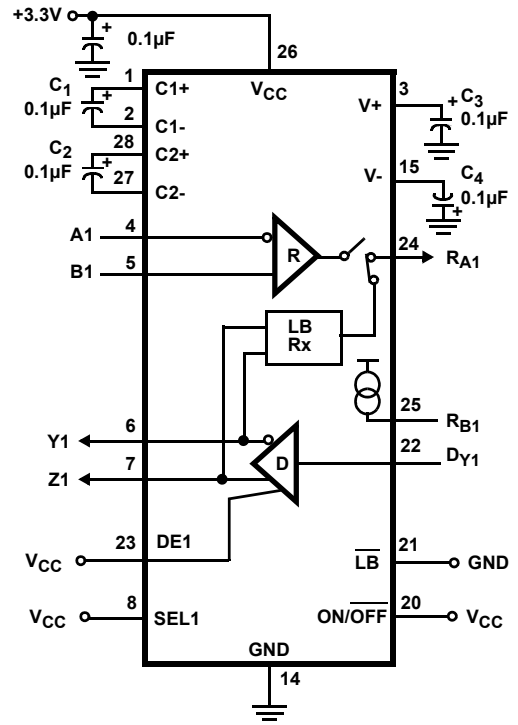

NOTE: PINOUT FOR SSOP  
SAME FOR PORT 2.

**Absolute Maximum Ratings** ( $T_A = +25^\circ\text{C}$ )

|                               |                              |
|-------------------------------|------------------------------|
| $V_{CC}$ to Ground            | 7V                           |
| $V_L$ (QFN Only)              | -0.5V to $V_{CC} + 0.5V$     |
| Input Voltages                |                              |
| All Except A,B                | -0.5V to 7V                  |
| Input/Output Voltages         |                              |
| A, B (Any Mode)               | -25V to +25V                 |
| Y, Z (Any Mode, Note 6)       | -12.5V to +12.5V             |
| $R_A, R_B$ (non-QFN Package)  | -0.5V to ( $V_{CC} + 0.5V$ ) |
| $R_A, R_B$ (QFN Package)      | -0.5V to ( $V_L + 0.5V$ )    |
| Output Short Circuit Duration |                              |
| Y, Z, $R_A, R_B$              | Indefinite                   |
| ESD Rating                    | See Specification Table      |

**Thermal Information**

|  |   |   |
|--|---|---|
| Thermal Resistance (Typical)                   | $\theta_{JA}$ ( $^\circ\text{C}/\text{W}$ )   | $\theta_{JC}$ ( $^\circ\text{C}/\text{W}$ ) |
| 28 Ld SSOP Package (Note 8)                    | 60  | N/A   |
| 40 Ld QFN Package (Notes 7, 9)                 | 31  | 2.5   |
| Maximum Junction Temperature (Plastic Package) | +150 $^\circ\text{C}$                         |   |
| Maximum Storage Temperature Range              | -65 $^\circ\text{C}$ to +150 $^\circ\text{C}$ |   |
| Pb-free reflow profile                         | see <a href="#">TB493</a>                     |   |

**Operating Conditions**

|                   |  |
|-------------------|--|
| Temperature Range | -40 $^\circ\text{C}$ to +85 $^\circ\text{C}$ |
|-------------------|--|

**CAUTION:** Do not operate at or near the maximum ratings listed for extended periods of time. Exposure to such conditions can adversely impact product reliability and result in failures not covered by warranty.

## NOTES:

- One output at a time,  $I_{OUT} \leq 100\text{mA}$  for  $\leq 10$  mins.
- $\theta_{JA}$  is measured in free air with the component mounted on a high effective thermal conductivity test board with direct attach features. See [TB379](#).
- $\theta_{JA}$  is measured with the component mounted on a high effective thermal conductivity test board in free air. See [TB379](#) for details.
- For  $\theta_{JC}$ , the case temperature location is the center of the exposed metal pad on the package underside.

Electrical Specifications      Test Conditions:  $V_{CC} = 3.15V$  to  $3.45V$ ,  $C1 - C4 = 0.1\mu\text{F}$ ,  $V_L = V_{CC}$  (for QFN only); Unless Otherwise Specified. Typicals are at  $V_{CC} = 3.3V$ ,  $T_A = +25^\circ\text{C}$  (Note 10)

| PARAMETER  | SYMBOL          | TEST CONDITIONS   | TEMP<br>( $^\circ\text{C}$ ) | MIN<br>(Note 14) | TYP             | MAX<br>(Note 14) | UNITS |               |
|--|-----------------|---|------------------------------|------------------|-----------------|------------------|-------|---------------|
| <b>DC CHARACTERISTICS - RS-485 DRIVER (SEL = <math>V_{CC}</math>)</b>                |                 |   |                              |                  |                 |                  |       |               |
| Driver Differential $V_{OUT}$ (no load)  | $V_{OD1}$       |   | Full                         | -                | -               | $V_{CC}$         | V     |               |
| Driver Differential $V_{OUT}$ (with load)  | $V_{OD2}$       | $R = 50\Omega$ (RS-422) (Figure 1)                                      | Full                         | 2                | 2.3             | -                | V     |               |
|  |                 | $R = 27\Omega$ (RS-485) (Figure 1)                                      | Full                         | 1.5              | 2               | 5                | V     |               |
|  | $V_{OD3}$       | $R_D = 60\Omega$ , $R = 375\Omega$ , $V_{CM} = -7V$ to $12V$ (Figure 1) | Full                         | 1.5              | -               | 5                | V     |               |
| Change in Magnitude of Driver Differential $V_{OUT}$ for Complementary Output States | $\Delta V_{OD}$ | $R = 27\Omega$ or $50\Omega$ (Figure 1)                                 | Full                         | -                | 0.01            | 0.2              | V     |               |
| Driver Common-Mode $V_{OUT}$   | $V_{OC}$        | $R = 27\Omega$ or $50\Omega$ (Figure 1)                                 | Full                         | -                | -               | 3.0              | V     |               |
| Change in Magnitude of Driver Common-Mode $V_{OUT}$ for Complementary Output States  | $\Delta V_{OC}$ | $R = 27\Omega$ or $50\Omega$ (Figure 1)                                 | Full                         | -                | 0.01            | 0.2              | V     |               |
| Driver Short-Circuit Current, $V_{OUT} = \text{High or Low}$                         | $I_{OS}$        | $-7V \leq (V_Y \text{ or } V_Z) \leq 12V$ (Note 8)                      | Full                         | 35               | -               | 250              | mA    |               |
| Driver Three-State Output Leakage Current (Y, Z)                                     | $I_{OZ}$        | Outputs Disabled, $V_{CC} = 0V$ or $3.6V$                               | $V_{OUT} = 12V$              | Full             | -               | -                | 200   | $\mu\text{A}$ |
|  |                 |   | $V_{OUT} = -7V$              | Full             | -200            | -                | -     | $\mu\text{A}$ |
| <b>DC CHARACTERISTICS - RS-232 DRIVER (SEL = GND)</b>                                |                 |   |                              |                  |                 |                  |       |               |
| Driver Output Voltage Swing  | $V_O$           | All $T_{OUTS}$ Loaded with $3k\Omega$ to Ground                         | Full                         | $\pm 5.0$        | -               | -                | V     |               |
| Driver Output Short-Circuit Current  | $I_{OS}$        | $V_{OUT} = 0V$  | Full                         | -60              | -               | 60               | mA    |               |
| <b>DC CHARACTERISTICS - LOGIC PINS (i.e., DRIVER AND CONTROL INPUT PINS)</b>         |                 |   |                              |                  |                 |                  |       |               |
| Input High Voltage   | $V_{IH1}$       | $V_L = V_{CC}$ if QFN   | Full                         | 2.2              | -               | -                | V     |               |
|  | $V_{IH2}$       | $2.7V \leq V_L < 3.0V$ (QFN Only)                                       | Full                         | 2                | -               | -                | V     |               |
|  | $V_{IH3}$       | $2.3V \leq V_L < 2.7V$ (QFN Only)                                       | Full                         | 1.6              | -               | -                | V     |               |
|  | $V_{IH4}$       | $1.6V \leq V_L < 2.3V$ (QFN Only)                                       | Full                         | $0.7 \cdot V_L$  | -               | -                | V     |               |
|  | $V_{IH5}$       | $1.2V \leq V_L < 1.6V$ (QFN Only)                                       | 25                           | -                | $0.7 \cdot V_L$ | -                | V     |               |

| PARAMETER  | SYMBOL          | TEST CONDITIONS  | TEMP (°C)      | MIN (Note 14) | TYP              | MAX (Note 14)    | UNITS     |         |
|--|-----------------|--|----------------|---------------|------------------|------------------|-----------|---------|
| Input Low Voltage  | $V_{IL1}$       | $V_L = V_{CC}$ if QFN  | Full           | -             | -                | 0.8              | V         |         |
|  | $V_{IL2}$       | $V_L \geq 2.7V$ (QFN Only)   | Full           | -             | -                | 0.8              | V         |         |
|  | $V_{IL3}$       | $2.3V \leq V_L < 2.7V$ (QFN Only)  | Full           | -             | -                | 0.7              | V         |         |
|  | $V_{IL4}$       | $1.6V \leq V_L < 2.3V$ (QFN Only)  | Full           | -             | -                | $0.35 \cdot V_L$ | V         |         |
|  | $V_{IL5}$       | $1.3V \leq V_L < 1.6V$ (QFN Only)  | 25             | -             | $0.35 \cdot V_L$ | -                | V         |         |
|  | $V_{IL6}$       | $1.2V \leq V_L < 1.3V$ (QFN Only)  | 25             | -             | $0.25 \cdot V_L$ | -                | V         |         |
| Input Current  | $I_{IN1}$       | Pins Without Pull-ups or Pull-downs  | Full           | -2            | -                | 2                | $\mu A$   |         |
|  | $I_{IN2}$       | $\overline{LB}$ , $ON/\overline{OFF}$ , $DE$ (SP, $\overline{RXEN}$ , $DEN$ , if QFN)                | Full           | -25           | -                | 25               | $\mu A$   |         |
| <b>DC CHARACTERISTICS - RS-485 RECEIVER INPUTS (SEL = <math>V_{CC}</math>)</b> |                 |  |                |               |                  |                  |           |         |
| Receiver Differential Threshold Voltage  | $V_{TH}$        | $-7V \leq V_{CM} \leq 12V$ , Full Failsafe   | Full           | -0.2          | -                | -0.04            | V         |         |
| Receiver Input Hysteresis  | $\Delta V_{TH}$ | $V_{CM} = 0V$  | 25             | -             | 35               | -                | mV        |         |
| Receiver Input Current (A, B)  | $I_{IN}$        | $V_{CC} = 0V$ or $3.0$ to $3.6V$   | $V_{IN} = 12V$ | Full          | -                | -                | 0.8       | mA      |
|  |                 |  | $V_{IN} = -7V$ | Full          | -0.64            | -                | -         | mA      |
| Receiver Input Resistance  | $R_{IN}$        | $-7V \leq V_{CM} \leq 12V$ , $V_{CC} = 0$ (Note 9) or $3.0V \leq V_{CC} \leq 3.6V$                   | Full           | 15            | -                | -                | $k\Omega$ |         |
| <b>DC CHARACTERISTICS - RS-232 RECEIVER INPUTS (SEL = GND)</b>                 |                 |  |                |               |                  |                  |           |         |
| Receiver Input Voltage Range   | $V_{IN}$        |  | Full           | -25           | -                | 25               | V         |         |
| Receiver Input Threshold   | $V_{IL}$        |  | Full           | -             | 1.1              | 0.8              | V         |         |
|  | $V_{IH}$        |  | Full           | 2.4           | 1.6              | -                | V         |         |
| Receiver Input Hysteresis  | $\Delta V_{TH}$ |  | 25             | -             | 0.5              | -                | V         |         |
| Receiver Input Resistance  | $R_{IN}$        | $V_{IN} = \pm 15V$ , $V_{CC}$ Powered Up (Note 9)  | Full           | 3             | 5                | 7                | $k\Omega$ |         |
| <b>DC CHARACTERISTICS - RECEIVER OUTPUTS (485 OR 232 MODE)</b>                 |                 |  |                |               |                  |                  |           |         |
| Receiver Output High Voltage   | $V_{OH1}$       | $I_O = -1.5mA$ ( $V_L = V_{CC}$ if QFN)  | Full           | $V_{CC}-0.4$  | -                | -                | V         |         |
|  | $V_{OH2}$       | $I_O = -100\mu A$ , $V_L \geq 1.2V$ (QFN Only)   | Full           | $V_L-0.1$     | -                | -                | V         |         |
|  | $V_{OH3}$       | $I_O = -500\mu A$ , $V_L = 1.5V$ (QFN Only)  | Full           | 1.2           | -                | -                | V         |         |
|  | $V_{OH4}$       | $I_O = -150\mu A$ , $V_L = 1.2V$ (QFN Only)  | Full           | 1.0           | -                | -                | V         |         |
| Receiver Output Low Voltage  | $V_{OL}$        | $I_O = 5mA$  | Full           | -             | 0.2              | 0.4              | V         |         |
| Receiver Short-Circuit Current   | $I_{OSR}$       | $0V \leq V_O \leq V_{CC}$  | Full           | 7             | -                | 85               | mA        |         |
| Receiver Three-State Output Current  | $I_{OZR}$       | Output Disabled, $0V \leq V_O \leq V_{CC}$ (or $V_L$ for QFN)  | Full           | -             | -                | $\pm 10$         | $\mu A$   |         |
| Unused Receiver ( $R_B$ ) Pull-Up Resistance                                   | $R_{OBZ}$       | $ON/\overline{OFF} = V_{CC}$ , $SELX = V_{CC}$ (RS-485 Mode)   | 25             | -             | 40               | -                | $k\Omega$ |         |
| <b>POWER SUPPLY CHARACTERISTICS</b>  |                 |  |                |               |                  |                  |           |         |
| No-Load Supply Current, (Note 7)   | $I_{CC232}$     | $SEL1$ or $SEL2 = GND$ , $\overline{LB} = ON/\overline{OFF} = V_{CC}$                                | Full           | -             | 3.7              | 7                | mA        |         |
|  | $I_{CC485}$     | $SEL1$ & $2 = \overline{LB} = DE = ON/\overline{OFF} = V_{CC}$                                       | Full           | -             | 1.6              | 5                | mA        |         |
| Shutdown Supply Current  | $I_{SHDN232}$   | $ON/\overline{OFF} = SELX = GND$ , $\overline{LB} = V_{CC}$ , (SPX = $V_L$ , DENX = GND if QFN)      | Full           | -             | 45               | 100              | $\mu A$   |         |
|  | $I_{SHDN485}$   | $ON/\overline{OFF} = DEX = GND$ , $SELX = \overline{LB} = V_{CC}$ , (SPX = GND, DENX = $V_L$ if QFN) | SSOP           | Full          | -                | 35               | 80        | $\mu A$ |
| QFN  |                 |  | Full           | -             | 60               | 160              | $\mu A$   |         |
| <b>ESD CHARACTERISTICS</b>   |                 |  |                |               |                  |                  |           |         |
| Bus Pins (A, B, Y, Z) Any Mode   |                 | Human Body Model   | 25             | -             | $\pm 15$         | -                | kV        |         |
| All Other Pins   |                 | Human Body Model   | 25             | -             | $\pm 2.5$        | -                | kV        |         |
|  |                 | Machine Model  | 25             | -             | $\pm 200$        | -                | V         |         |



## Electrical Specifications

Test Conditions:  $V_{CC} = 3.15V$  to  $3.45V$ ,  $C_1 - C_4 = 0.1\mu F$ ,  $V_L = V_{CC}$  (for QFN only); Unless Otherwise Specified.  
Typicals are at  $V_{CC} = 3.3V$ ,  $T_A = +25^\circ C$  (Note 10) (Continued)

| PARAMETER  | SYMBOL             | TEST CONDITIONS   | TEMP (°C)         | MIN (Note 14) | TYP  | MAX (Note 14) | UNITS   |            |
|--|--------------------|---|-------------------|---------------|------|---------------|---------|------------|
| <b>RS-232 DRIVER AND RECEIVER SWITCHING CHARACTERISTICS (SEL = GND, ALL VERSIONS AND SPEEDS)</b>   |                    |   |                   |               |      |               |         |            |
| Driver Output Transition Region Slew Rate  | SR                 | $R_L = 3k\Omega$ , Measured From 3V to -3V or -3V to 3V                   | $C_L \geq 15pF$   | Full          | -    | 20            | 30      | V/ $\mu s$ |
|  |                    |   | $C_L \leq 2500pF$ | Full          | 4    | 9             | -       | V/ $\mu s$ |
| Driver Output Transition Time  | $t_r, t_f$         | $R_L = 3k\Omega$ , $C_L = 2500pF$ , 10% - 90%                             | Full              | 0.22          | 1.2  | 3.1           | $\mu s$ |            |
| Driver Propagation Delay   | $t_{DPHL}$         | $R_L = 3k\Omega$ , $C_L = 1000pF$ (Figure 6)                              | Full              | -             | 1    | 2             | $\mu s$ |            |
|  | $t_{DPLH}$         |   | Full              | -             | 1.2  | 2             | $\mu s$ |            |
| Driver Propagation Delay Skew  | $t_{DSKEW}$        | $t_{DPHL} - t_{DPLH}$ (Figure 6)  | Full              | -             | 300  | 450           | ns      |            |
| Driver Enable Time (QFN Only)  | $t_{DEN}$          | $C_L = 1000pF$  | 25                | -             | 1500 | -             | ns      |            |
| Driver Disable Time (QFN Only)   | $t_{DDIS}$         | $R_L = 5k\Omega$ , Measured at $V_{OUT} = \pm 3V$ , $C_L = 30pF$          | 25                | -             | 500  | -             | ns      |            |
| Driver Enable Time from Shutdown   | $t_{DENSD}$        | $V_{OUT} = \pm 3.0V$ , $C_L = 1000pF$                                     | 25                | -             | 25   | -             | $\mu s$ |            |
| Driver Maximum Data Rate   | $DR_D$             | $R_L = 3k\Omega$ , $C_L = 500pF$ , One Transmitter Switching on Each Port | Full              | 250           | 400  | -             | kbps    |            |
| Receiver Propagation Delay   | $t_{RPHL}$         | $C_L = 15pF$ (Figure 7)   | Full              | -             | 40   | 120           | ns      |            |
|  | $t_{RPLH}$         |   | Full              | -             | 58   | 120           | ns      |            |
| Receiver Propagation Delay Skew  | $t_{RSKEW}$        | $t_{RPHL} - t_{RPLH}$ (Figure 7)  | Full              | -             | 18   | 40            | ns      |            |
| Receiver Maximum Data Rate   | $DR_R$             | $C_L = 15pF$  | Full              | 0.46          | 2    | -             | Mbps    |            |
| Receiver Enable to Output Low  | $t_{ZL}$           | QFN Only, $C_L = 15pF$ , $SW = V_{CC}$                                    | Full              | -             | 18   | -             | ns      |            |
| Receiver Enable to Output High   | $t_{ZH}$           | QFN Only, $C_L = 15pF$ , $SW = GND$                                       | Full              | -             | 18   | -             | ns      |            |
| Receiver Disable from Output Low   | $t_{LZ}$           | QFN Only, $C_L = 15pF$ , $SW = V_{CC}$                                    | Full              | -             | 22   | -             | ns      |            |
| Receiver Disable from Output High  | $t_{HZ}$           | QFN Only, $C_L = 15pF$ , $SW = GND$                                       | Full              | -             | 22   | -             | ns      |            |
| Receiver Enable from Shutdown to Output Low  | $t_{ZLSHDN}$       | $C_L = 15pF$ , $SW = V_{CC}$  | 25                | -             | 60   | -             | ns      |            |
| Receiver Enable from Shutdown to Output High   | $t_{ZHSHDN}$       | $C_L = 15pF$ , $SW = GND$   | 25                | -             | 20   | -             | ns      |            |
| <b>RS-485 DRIVER SWITCHING CHARACTERISTICS (FAST DATA RATE (20Mbps), SEL = <math>V_{CC}</math>, ALL VERSIONS (SPA = <math>V_{CC}</math> if QFN))</b> |                    |   |                   |               |      |               |         |            |
| Driver Differential Input to Output Delay  | $t_{DLH}, t_{DHL}$ | $R_{DIFF} = 54\Omega$ , $C_L = 100pF$ (Figure 2)                          | Full              | 10            | 20   | 35            | ns      |            |
| Driver Output Skew   | $t_{SKEW}$         | $R_{DIFF} = 54\Omega$ , $C_L = 100pF$ (Figure 2)                          | Full              | -             | 2    | 10            | ns      |            |
| Driver Differential Rise or Fall Time  | $t_R, t_F$         | $R_{DIFF} = 54\Omega$ , $C_L = 100pF$ , (Figure 2)                        | Full              | 3             | 20   | 30            | ns      |            |
| Driver Enable to Output Low  | $t_{ZL}$           | $C_L = 100pF$ , $SW = V_{CC}$ (Figure 3)                                  | Full              | -             | 28   | 60            | ns      |            |
| Driver Enable to Output High   | $t_{ZH}$           | $C_L = 100pF$ , $SW = GND$ (Figure 3)                                     | Full              | -             | 35   | 60            | ns      |            |
| Driver Disable from Output Low   | $t_{LZ}$           | $C_L = 15pF$ , $SW = V_{CC}$ (Figure 3)                                   | Full              | -             | 30   | 60            | ns      |            |
| Driver Disable from Output High  | $t_{HZ}$           | $C_L = 15pF$ , $SW = GND$ (Figure 3)                                      | Full              | -             | 30   | 60            | ns      |            |
| Driver Enable from Shutdown to Output Low  | $t_{ZL(SHDN)}$     | $R_L = 500\Omega$ , $C_L = 100pF$ , $SW = V_{CC}$ (Figure 3)              | Full              | -             | 100  | 250           | ns      |            |
| Driver Enable from Shutdown to Output High   | $t_{ZH(SHDN)}$     | $R_L = 500\Omega$ , $C_L = 100pF$ , $SW = GND$ (Figure 3)                 | Full              | -             | 290  | 375           | ns      |            |
| Driver Maximum Data Rate   | $f_{MAX}$          | $R_{DIFF} = 54\Omega$ , $C_L = 100pF$ (Figure 2)                          | Full              | 20            | 35   | -             | Mbps    |            |
| <b>RS-485 DRIVER SWITCHING CHARACTERISTICS (MEDIUM DATA RATE (460kbps, QFN ONLY), SEL = <math>V_{CC}</math>, SPA = SPB= GND)</b>                     |                    |   |                   |               |      |               |         |            |
| Driver Differential Input to Output Delay  | $t_{DLH}, t_{DHL}$ | $R_{DIFF} = 54\Omega$ , $C_L = 100pF$ (Figure 2)                          | Full              | 200           | 500  | 1000          | ns      |            |
| Driver Output Skew   | $t_{SKEW}$         | $R_{DIFF} = 54\Omega$ , $C_L = 100pF$ (Figure 2)                          | Full              | -             | 10   | 150           | ns      |            |
| Driver Differential Rise or Fall Time  | $t_R, t_F$         | $R_{DIFF} = 54\Omega$ , $C_L = 100pF$ (Figure 2)                          | Full              | 300           | 660  | 1100          | ns      |            |
| Driver Enable to Output Low  | $t_{ZL}$           | $C_L = 100pF$ , $SW = V_{CC}$ (Figure 3)                                  | Full              | -             | 42   | 100           | ns      |            |

## Electrical Specifications

Test Conditions:  $V_{CC} = 3.15V$  to  $3.45V$ ,  $C_1 - C_4 = 0.1\mu F$ ,  $V_L = V_{CC}$  (for QFN only); Unless Otherwise Specified.  
Typicals are at  $V_{CC} = 3.3V$ ,  $T_A = +25^\circ C$  (Note 10) (Continued)

| PARAMETER  | SYMBOL                | TEST CONDITIONS  | TEMP (°C) | MIN (Note 14) | TYP  | MAX (Note 14) | UNITS |
|--|-----------------------|--|-----------|---------------|------|---------------|-------|
| Driver Enable to Output High   | $t_{ZH}$              | $C_L = 100pF$ , SW = GND (Figure 3)                          | Full      | -             | 350  | 450           | ns    |
| Driver Disable from Output Low   | $t_{LZ}$              | $C_L = 15pF$ , SW = $V_{CC}$ (Figure 3)                      | Full      | -             | 30   | 60            | ns    |
| Driver Disable from Output High  | $t_{HZ}$              | $C_L = 15pF$ , SW = GND (Figure 3)                           | Full      | -             | 30   | 60            | ns    |
| Driver Enable from Shutdown to Output Low  | $t_{ZL}(SHDN)$        | $R_L = 500\Omega$ , $C_L = 100pF$ , SW = $V_{CC}$ (Figure 3) | Full      | -             | -    | 500           | ns    |
| Driver Enable from Shutdown to Output High   | $t_{ZH}(SHDN)$        | $R_L = 500\Omega$ , $C_L = 100pF$ , SW = GND (Figure 3)      | Full      | -             | -    | 750           | ns    |
| Driver Maximum Data Rate   | $f_{MAX}$             | $R_{DIFF} = 54\Omega$ , $C_L = 100pF$ (Figure 2)             | Full      | 460           | 2000 | -             | kbps  |
| <b>RS-485 DRIVER SWITCHING CHARACTERISTICS (SLOW DATA RATE (115kbps, QFN ONLY), SEL = <math>V_{CC}</math>, SPA = GND, SPB = <math>V_{CC}</math>)</b> |                       |  |           |               |      |               |       |
| Driver Differential Input to Output Delay  | $t_{DLH}$ , $t_{DHL}$ | $R_{DIFF} = 54\Omega$ , $C_L = 100pF$ (Figure 2)             | Full      | 800           | 1600 | 2500          | ns    |
| Driver Output Skew   | $t_{SKEW}$            | $R_{DIFF} = 54\Omega$ , $C_L = 100pF$ (Figure 2)             | Full      | -             | 250  | 500           | ns    |
| Driver Differential Rise or Fall Time  | $t_R$ , $t_F$         | $R_{DIFF} = 54\Omega$ , $C_L = 100pF$ (Figure 2)             | Full      | 1000          | 1700 | 3100          | ns    |
| Driver Enable to Output Low  | $t_{ZL}$              | $C_L = 100pF$ , SW = $V_{CC}$ (Figure 3)                     | Full      | -             | 45   | 100           | ns    |
| Driver Enable to Output High   | $t_{ZH}$              | $C_L = 100pF$ , SW = GND (Figure 3)                          | Full      | -             | 900  | 1200          | ns    |
| Driver Disable from Output Low   | $t_{LZ}$              | $C_L = 15pF$ , SW = $V_{CC}$ (Figure 3)                      | Full      | -             | 35   | 60            | ns    |
| Driver Disable from Output High  | $t_{HZ}$              | $C_L = 15pF$ , SW = GND (Figure 3)                           | Full      | -             | 25   | 60            | ns    |
| Driver Enable from Shutdown to Output Low  | $t_{ZL}(SHDN)$        | $R_L = 500\Omega$ , $C_L = 100pF$ , SW = $V_{CC}$ (Figure 3) | Full      | -             | -    | 800           | ns    |
| Driver Enable from Shutdown to Output High   | $t_{ZH}(SHDN)$        | $R_L = 500\Omega$ , $C_L = 100pF$ , SW = GND (Figure 3)      | Full      | -             | -    | 1500          | ns    |
| Driver Maximum Data Rate   | $f_{MAX}$             | $R_{DIFF} = 54\Omega$ , $C_L = 100pF$ (Figure 2)             | Full      | 115           | 800  | -             | kbps  |
| <b>RS-485 RECEIVER SWITCHING CHARACTERISTICS (SEL = <math>V_{CC}</math>, ALL VERSIONS AND SPEEDS)</b>  |                       |  |           |               |      |               |       |
| Receiver Input to Output Delay   | $t_{PLH}$ , $t_{PHL}$ | (Figure 4)   | Full      | 20            | 45   | 70            | ns    |
| Receiver Skew   $t_{PLH} - t_{PHL}$  | $t_{SKEW}$            | (Figure 4)   | Full      | -             | 3    | 10            | ns    |
| Receiver Maximum Data Rate   | $f_{MAX}$             |  | Full      | 20            | 40   | -             | Mbps  |
| Receiver Enable to Output Low  | $t_{ZL}$              | QFN Only, $C_L = 15pF$ , SW = $V_{CC}$ (Figure 5)            | Full      | -             | 20   | 60            | ns    |
| Receiver Enable to Output High   | $t_{ZH}$              | QFN Only, $C_L = 15pF$ , SW = GND (Figure 5)                 | Full      | -             | 20   | 60            | ns    |
| Receiver Disable from Output Low   | $t_{LZ}$              | QFN Only, $C_L = 15pF$ , SW = $V_{CC}$ (Figure 5)            | Full      | -             | 20   | 60            | ns    |
| Receiver Disable from Output High  | $t_{HZ}$              | QFN Only, $C_L = 15pF$ , SW = GND (Figure 5)                 | Full      | -             | 20   | 60            | ns    |
| Receiver Enable from Shutdown to Output Low  | $t_{ZL}SHDN$          | $C_L = 15pF$ , SW = $V_{CC}$ (Figure 5)                      | Full      | -             | 500  | 900           | ns    |
| Receiver Enable from Shutdown to Output High   | $t_{ZH}SHDN$          | $C_L = 15pF$ , SW = GND (Figure 5)                           | Full      | -             | 500  | 900           | ns    |

## NOTES:

- All currents into device pins are positive; all currents out of device pins are negative. All voltages are referenced to device ground unless otherwise specified.
- Supply current specification is valid for loaded drivers when DE = 0V (RS-485 mode) or DEN = 0V (RS-232 mode).
- Applies to peak current. See "Typical Performance Curves" for more information.
- $R_{IN}$  defaults to RS-485 mode (>15k $\Omega$ ) when the device is unpowered ( $V_{CC} = 0V$ ), or in SHDN, regardless of the state of the SEL inputs.
- Parameters with MIN and/or MAX limits are 100% tested at +25°C, unless otherwise specified. Temperature limits established by characterization and are not production tested.

**Test Circuits and Waveforms**

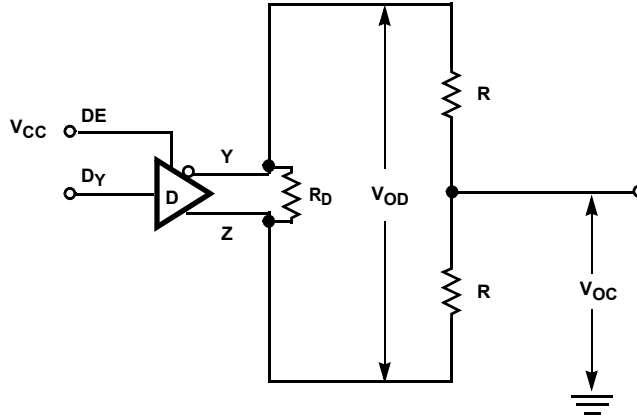

**FIGURE 1. RS-485 DRIVER  $V_{OD}$  AND  $V_{OC}$  TEST CIRCUIT**

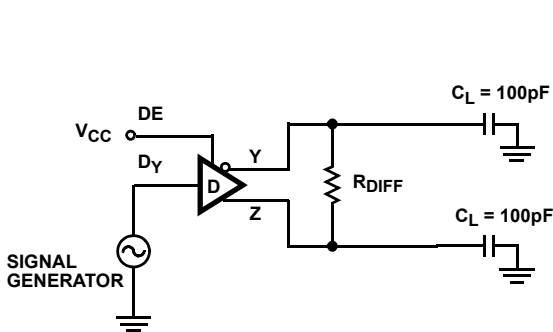

**FIGURE 2A. TEST CIRCUIT**

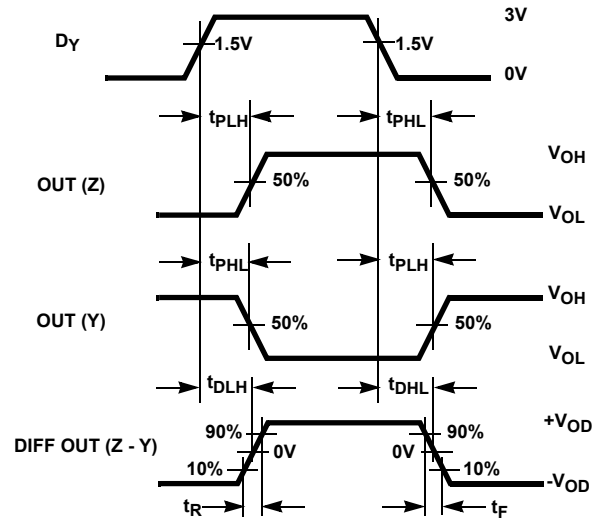

$$\text{SKEW} = |t_{PLH}(Y \text{ or } Z) - t_{PHL}(Z \text{ or } Y)|$$

**FIGURE 2B. MEASUREMENT POINTS**

**FIGURE 2. RS-485 DRIVER PROPAGATION DELAY AND DIFFERENTIAL TRANSITION TIMES**

**Test Circuits and Waveforms** (Continued)

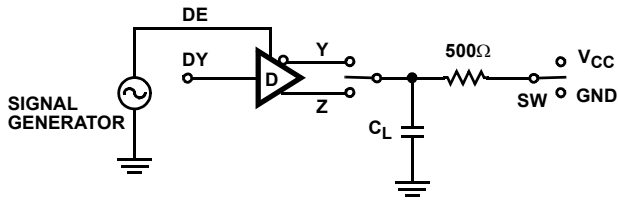

FOR SHDN TESTS, SWITCH ON/OFF RATHER THAN DE

| PARAMETER      | ON/DE | OUTPUT | DY  | SW       | CL (pF) |
|----------------|-------|--------|-----|----------|---------|
| $t_{HZ}$       | 1/-   | Y/Z    | 0/1 | GND      | 15      |
| $t_{LZ}$       | 1/-   | Y/Z    | 1/0 | $V_{CC}$ | 15      |
| $t_{ZH}$       | 1/-   | Y/Z    | 0/1 | GND      | 100     |
| $t_{ZL}$       | 1/-   | Y/Z    | 1/0 | $V_{CC}$ | 100     |
| $t_{ZH(SHDN)}$ | -/1   | Y/Z    | 0/1 | GND      | 100     |
| $t_{ZL(SHDN)}$ | -/1   | Y/Z    | 1/0 | $V_{CC}$ | 100     |

FIGURE 3A. TEST CIRCUIT

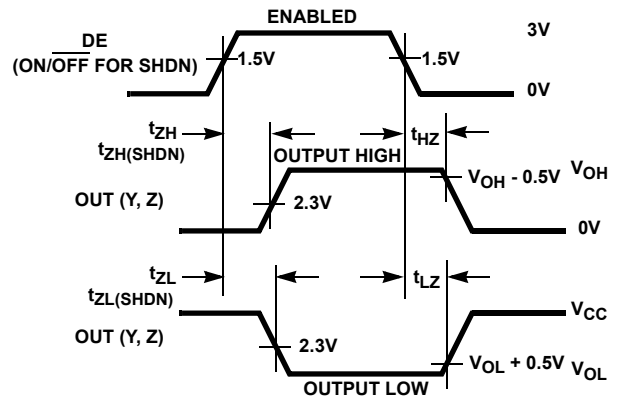

FIGURE 3B. MEASUREMENT POINTS

FIGURE 3. RS-485 DRIVER ENABLE AND DISABLE TIMES

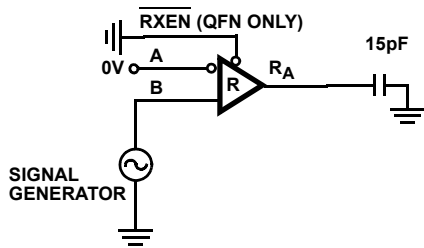

FIGURE 4A. TEST CIRCUIT

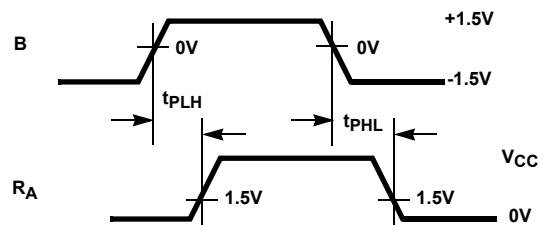
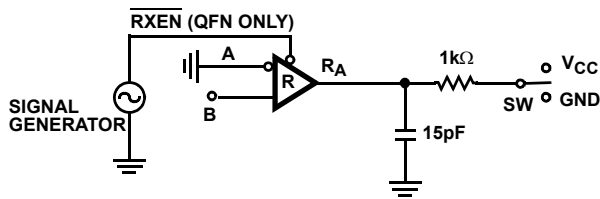

FIGURE 4B. MEASUREMENT POINTS

FIGURE 4. RS-485 RECEIVER PROPAGATION DELAY



FOR SHDN TESTS, SWITCH ON/OFF RATHER THAN RXEN

| PARAMETER           | ON/RXEN | B     | SW       |
|---------------------|---------|-------|----------|
| $t_{HZ}$ (QFN Only) | 1/-     | +1.5V | GND      |
| $t_{LZ}$ (QFN Only) | 1/-     | -1.5V | $V_{CC}$ |
| $t_{ZH}$ (QFN Only) | 1/-     | +1.5V | GND      |
| $t_{ZL}$ (QFN Only) | 1/-     | -1.5V | $V_{CC}$ |
| $t_{ZH(SHDN)}$      | -/0     | +1.5V | GND      |
| $t_{ZL(SHDN)}$      | -/0     | -1.5V | $V_{CC}$ |

FIGURE 5A. TEST CIRCUIT

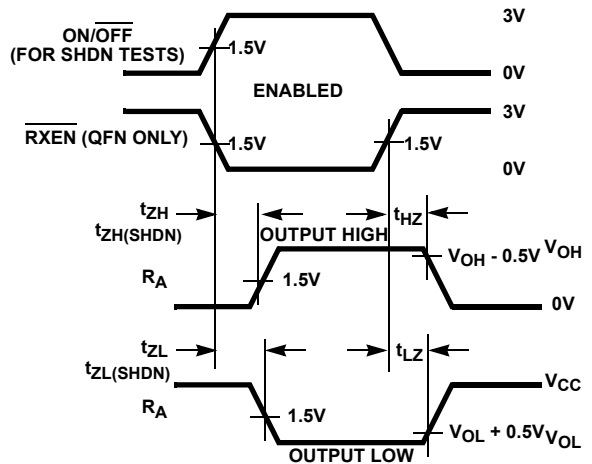

FIGURE 5B. MEASUREMENT POINTS

FIGURE 5. RS-485 RECEIVER ENABLE AND DISABLE TIMES

**Test Circuits and Waveforms** (Continued)

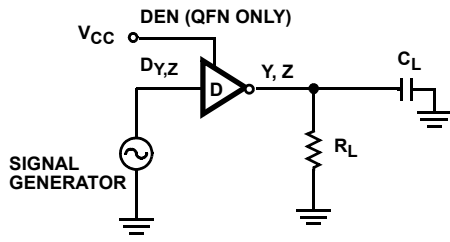

FIGURE 6A. TEST CIRCUIT

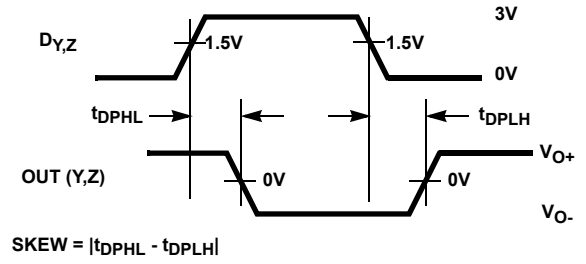

FIGURE 6B. MEASUREMENT POINTS

FIGURE 6. RS-232 DRIVER PROPAGATION DELAY AND TRANSITION TIMES

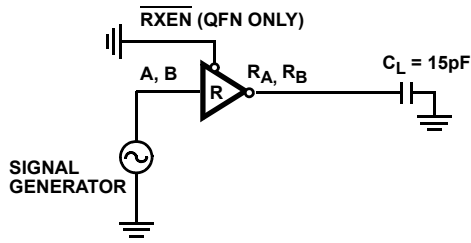

FIGURE 7A. TEST CIRCUIT

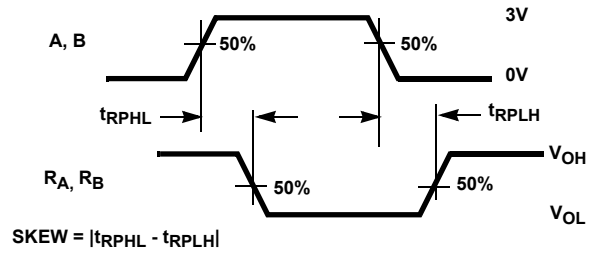

FIGURE 7B. MEASUREMENT POINTS

FIGURE 7. RS-232 RECEIVER PROPAGATION DELAY AND TRANSITION TIMES

## Typical Application

### RS-232 to RS-485 Converter

The ISL3332, ISL3333 are ideal for implementing a single IC 2-wire (Tx Data, Rx Data) protocol converter, because each port can be programmed for a different protocol. Figure 8 illustrates the simple connections to create a single transceiver RS-232 to RS-485 converter. Depending on the RS-232 data rate, using an RS-422 bus as an RS-232 "extension cord" can extend the transmission distance up to 4000' (1220m). A similar circuit on the other end of the cable completes the conversion to/from RS-232.

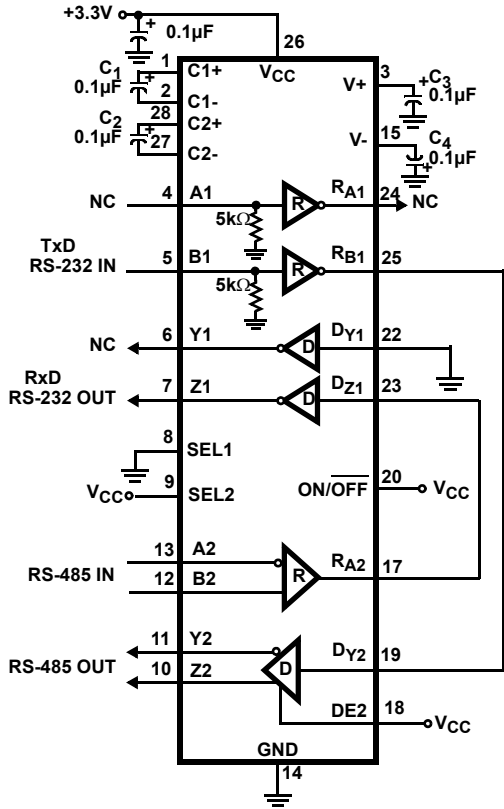

NOTE: PINOUT FOR SSOP

FIGURE 8. SINGLE IC RS-232 TO RS-485 CONVERTER

## Detailed Description

Each of the two ISL333X ports supports dual protocols: RS-485/422, and RS-232. RS-485 and RS-422 are differential (balanced) data transmission standards for use in high speed (up to 20Mbps) networks, or long haul and noisy environments. The differential signaling, coupled with RS-485's requirement for an extended common mode range (CMR) of +12V to -7V make these transceivers extremely tolerant of ground potential differences, as well as voltages induced in the cable by external fields. Both of these effects are real concerns when communicating over the RS-485/422 maximum distance of 4000' (1220m). **It is important to note that the ISL333X don't follow the RS-485 convention whereby the inverting I/O is labeled "B/Z", and the non inverting I/O is "A/Y". Thus, in the application diagrams below the 333X A/Y (B/Z) pins connect to the B/Z (A/Y) pins of the generic RS-485/RS-422 ICs.**

RS-422 is typically a point-to-point (one driver talking to one receiver on a bus), or a point-to-multipoint (multidrop) standard that allows only one driver and up to 10 receivers on each bus. Because of the one driver per bus limitation, RS-422 networks use a two bus, full duplex structure for bidirectional communication, and the Rx inputs and Tx outputs (no tri-state required) connect to different busses, as shown in Figure 10.

Conversely, RS-485 is a true multipoint standard, which allows up to 32 devices (any combination of drivers- must be tri-statable - and receivers) on each bus. Now bidirectional communication takes place on a single bus, so the Rx inputs and Tx outputs of a port connect to the same bus lines, as shown in Figure 9. Each port set to RS-485 /422 mode includes one Rx and one Tx. RS-232 is a point-to-point, singled ended (signal voltages referenced to GND) communication protocol targeting fairly short (<150', 46m) and low data rate (<1Mbps) applications. Each port contains two transceivers (2 Tx and 2 Rx) in RS-232 mode. Protocol selection is handled via a logic pin (SELX) for each port.

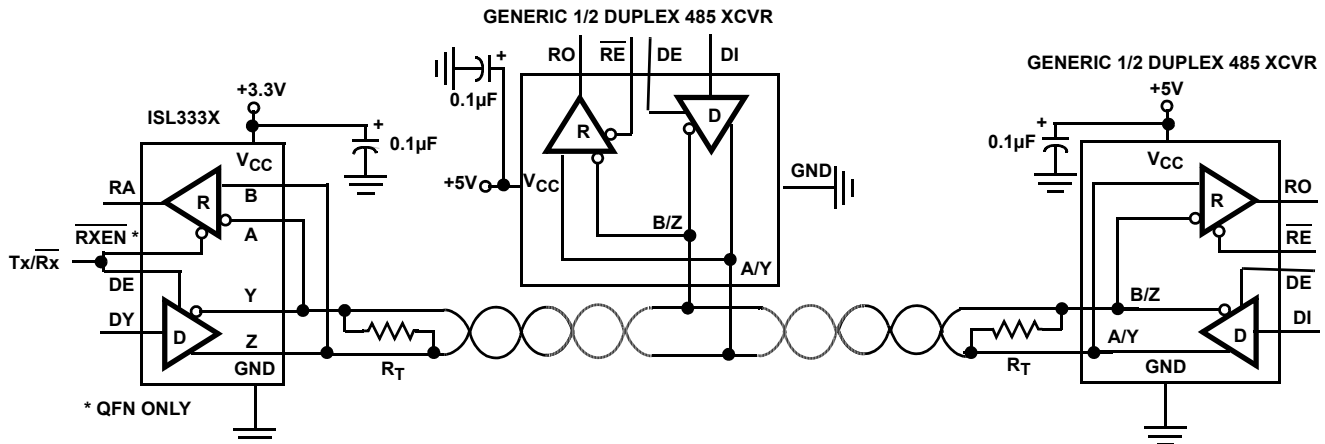

FIGURE 9. TYPICAL HALF DUPLEX RS-485 NETWORK

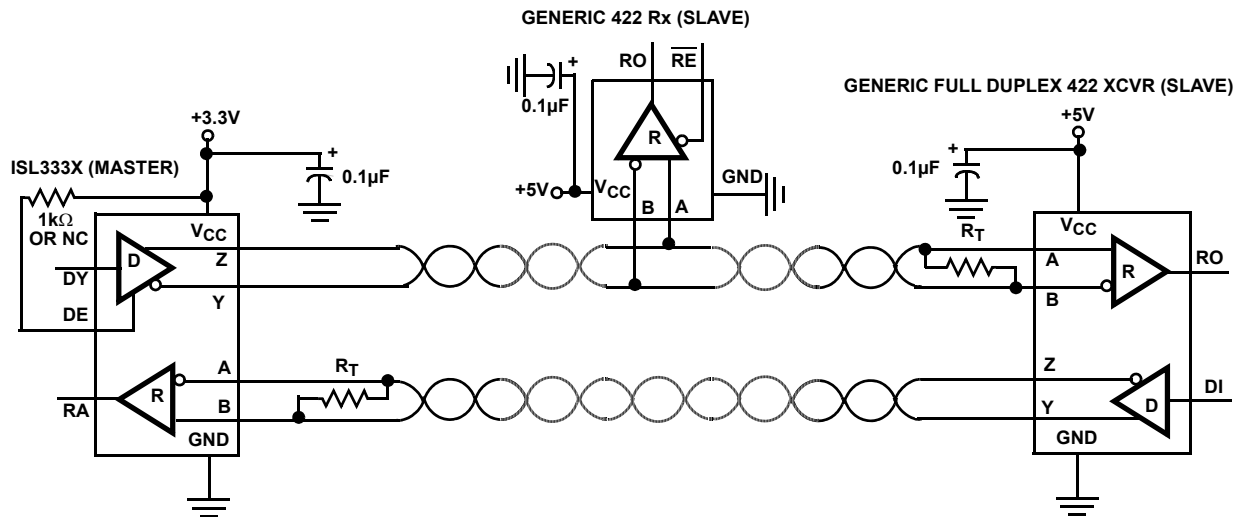

FIGURE 10. TYPICAL RS-422 NETWORK

### ISL333x Advantages

These dual protocol ICs offer many parametric improvements vs those offered on competing dual protocol devices. Some of the major improvements are:

- **3.3V Supply Voltage** - Eliminates the 5V supply that powers just the interface IC
- **15kV Bus Pin ESD** - Eases board level requirements
- **Full Failsafe RS-485 Rx** - Eliminates bus biasing
- **Selectable RS-485 Data Rate** - Up to 20Mbps, or slew rate limited for low EMI and fewer termination issues
- **High RS-232 Data Rate** - >250kbps
- **Lower Tx and Rx Skews** - Wider, consistent bit widths
- **Lower I<sub>CC</sub>** - Max I<sub>CC</sub> is 2x to -4x lower than competition
- **Flow-Thru Pinouts** - Tx, Rx bus pins on one side/logic pins on the other, for easy routing to connector/UART

**Packaging** - Smaller (QFN) and Pb-free.

### RS-232 Mode

#### Rx Features

RS-232 receivers invert and convert RS-232 input levels ( $\pm 3V$  to  $\pm 25V$ ) to the standard TTL/CMOS levels required by a UART, ASIC, or  $\mu$ controller serial port. Receivers are designed to operate at faster data rates than the drivers, and they feature very low skews (18ns) so the receivers contribute negligibly to bit width distortion. Inputs include the standards required 3k $\Omega$  to 7k $\Omega$  pull-down resistor, so unused inputs may be left unconnected. Rx inputs also have built-in hysteresis to increase noise immunity, and to decrease erroneous triggering due to slowly transitioning input signals.

Rx outputs are short circuit protected, and are only tristatable when the entire IC is shutdown (SHDN) via the

ON/OFF pin, or via the active low  $\overline{RXEN}$  pins available on the QFN package option (see “ISL3333 Special Features” for more details).

#### Tx Features

RS-232 drivers invert and convert the standard TTL/CMOS levels from a UART, or  $\mu$ controller serial port to RS-232 compliant levels ( $\pm 5V$  minimum). The Tx delivers these compliant output levels even at data rates of 400kbps, with loads of 500pF, and with one output in each port switching at this high rate. The drivers are designed for low skew (typically 12% of the 400kbps bit width), and are compliant to the RS-232 slew rate spec (4 to 30V/ $\mu$ s) for a wide range of load capacitances. Tx inputs float if left unconnected, and may cause I<sub>CC</sub> increases. For the best results, connect unused inputs to GND.

Tx outputs are short circuit protected, and incorporate a thermal SHDN feature to protect the IC in situations of severe power dissipation - see the RS-485 section for more details. All drivers disable in SHDN, or when the 3.3V power supply is off, and a port's drivers also disable via the corresponding DENX pin (see “ISL3333 Special Features” for more details) available on the QFN package option (see Tables 2 and 3 and the “Low Power Shutdown” section). The ISL3332's SHDN function is useful for disabling the outputs if both ports will always be disabled together (e.g., used as a four transceiver RS-232 port), and if it is acceptable for the Rx to be disabled as well.

#### Charge Pumps

The on-chip charge pumps create the RS-232 transmitter power supplies (typically +5.7/-5.3V) from a single supply as low as 3.15V, and are enabled only if either port is configured for RS-232 operation. The efficient design requires only four small 0.1 $\mu$ F capacitors for the voltage doubler and inverter functions. By operating discontinuously (i.e., turning off as soon as V+ and V- pump up to the

nominal values), the charge pump contribution to RS-232 mode  $I_{CC}$  is reduced significantly. Unlike competing devices that require the charge pump in RS-485 mode, disabling the charge pump saves power, and minimizes noise. If the application keeps both ports in RS-485 mode (e.g., a dedicated dual channel RS-485 interface), then the charge pump capacitors aren't even required.

### **Data Rates and Cabling**

Drivers operate at data rates up to 400kbps, and are guaranteed for data rates up to 250kbps. The charge pumps and drivers are designed such that one driver in each port can be operated at the rated load, and at 250kbps (see Figure 34). Figure 34 also shows that drivers can easily drive two to three thousand picofarads at data rates up to 250kbps, while still delivering compliant  $\pm 5V$  output levels.

Receivers operate at data rates up to 2Mbps. They are designed for a higher data rate to facilitate faster factory downloading of software into the final product, thereby improving the user's manufacturing throughput.

Figures 37 and 38 illustrate driver and receiver waveforms at 250kbps, and 500kbps, respectively. For these graphs, one driver of each port drives the specified capacitive load, and a receiver in the port.

RS-232 doesn't require anything special for cabling; just a single bus wire per transmitter and receiver, and another wire for GND. So an ISL333X RS-232 port uses a five conductor cable for interconnection. Bus terminations are not required, nor allowed, by the RS-232 standard.

## **RS-485 Mode**

### **Rx Features**

RS-485 receivers convert differential input signals as small as 200mV, as required by the RS-485 and RS-422 standards, to TTL/CMOS output levels. The differential Rx provides maximum sensitivity, noise immunity, and common mode rejection. Per the RS-485 standard, receiver inputs function with common mode voltages as great as +12V and -7V, regardless of supply voltage, making them ideal for long networks where induced voltages are a realistic concern. Each RS-485/RS-422 port includes a single receiver (RA), and the unused Rx output (RB) is disabled but pulled high by an internal current source. The internal current source turns off in SHDN.

Worst case receiver input currents are 20% lower than the 1 "unit load" (1mA) RS-485 limit, which translates to a 15k $\Omega$  minimum input resistance.

These receivers include a "full fail-safe" function that guarantees a high level receiver output if the receiver inputs are unconnected (floating), shorted together, or if the bus is terminated but undriven (i.e., differential voltage collapses to near zero due to termination). Failsafe with shorted, or terminated and undriven inputs is accomplished by setting

the Rx upper switching point at -40mV, thereby ensuring that the Rx recognizes a 0V differential as a high level.

All the Rx outputs are short circuit protected, and are tri-state when the IC is forced into SHDN, but ISL3332 (SSOP) receiver outputs are not independently tri-statable. ISL3333 (QFN) receiver outputs are tri-statable via an active low RXEN input for each port (see "ISL3333 Special Features" for more details).

### **Tx Features**

The RS-485/RS-422 driver is a differential output device that delivers at least 1.5V across a 54 $\Omega$  load (RS-485), and at least 2V across a 100 $\Omega$  load (RS-422). The drivers feature low propagation delay skew to maximize bit widths, and to minimize EMI.

To allow multiple drivers on a bus, the RS-485 spec requires that drivers survive worst case bus contentions undamaged. The ISL333X drivers meet this requirement via driver output short circuit current limits, and on-chip thermal shutdown circuitry. The output stages incorporate current limiting circuitry that ensures that the output current never exceeds the RS-485 spec, even at the common mode voltage range extremes of 12V and -7V. In the event of a major short circuit condition, devices also include a thermal shutdown feature that disables the drivers whenever the die temperature becomes excessive. This eliminates the power dissipation, allowing the die to cool. The drivers automatically re-enable after the die temperature drops about 15 degrees. If the contention persists, the thermal shutdown/re-enable cycle repeats until the fault is cleared. Receivers stay operational during thermal shutdown.

RS-485 multi-driver operation also requires drivers to include tri-state functionality, so each port has a DE pin to control this function. If the driver is used in an RS-422 network, such that driver tri-state isn't required, then the DE pin can be left unconnected and an internal pull-up keeps it in the enabled state. Drivers are also tri-stated when the IC is in SHDN, or when the 3.3V power supply is off.

### **Speed Options**

The ISL3332 (SSOP) has fixed, high slew rate driver outputs optimized for 20Mbps data rates. The ISL3333 (QFN) offers three user selectable data rate options: "Fast" for high slew rate and 20Mbps; "Medium" with slew rate limiting set for 460kbps; "Slow" with even more slew rate limiting for 115kbps operation. See the "Data Rate" and "Slew Rate Limited Data Rates" sections for more information.

Receiver performance is the same for all three speed options.

### **Data Rate, Cables, and Terminations**

RS-485/RS-422 are intended for network lengths up to 4000' (1220m), but the maximum system data rate decreases as the transmission length increases. Devices operating at the maximum data rate of 20Mbps are limited to maximum lengths of 20-100' (6-31m), while devices operating at or



below 115kbps can operate at the maximum length of 4000' (1220m).

Higher data rates require faster edges, so both the ISL333X versions offer an edge rate capable of 20Mbps data rates. The ISL3333 also offers two slew rate limited edge rates to minimize problems at slower data rates. Nevertheless, for the best jitter performance when driving long cables, the faster speed settings may be preferable, even at low data rates. See the "RS-485 Slew Rate Limited Data Rates" section for details.

Twisted pair is the cable of choice for RS-485/RS-422 networks. Twisted pair cables tend to pick up noise and other electromagnetically induced voltages as common mode signals, which are effectively rejected by the differential receivers in these ICs.

The preferred cable connection technique is "daisy-chaining", where the cable runs from the connector of one device directly to the connector of the next device, such that cable stub lengths are negligible. A "backbone" structure, where stubs run from the main backbone cable to each device's connector, is the next best choice, but care must be taken to ensure that each stub is electrically "short". See Table 4 for recommended maximum stub lengths for each speed option.

TABLE 4. RECOMMENDED STUB LENGTHS

| SPEED OPTION | MAXIMUM STUB LENGTH<br>ft (m) |
|--------------|-------------------------------|
| SLOW         | 350-500 (107-152)             |
| MED          | 100-150 (30.5 - 46)           |
| FAST         | 1-3 (0.3 - 0.9)               |

Proper termination is imperative to minimize reflections when using the 20Mbps speed option. Short networks using the medium and slow speed options need not be terminated, but terminations are recommended unless power dissipation is an overriding concern. Note that the RS-485 spec allows a maximum of two terminations on a network, otherwise the Tx output voltage may not meet the required  $V_{OD}$ .

In point-to-point, or point-to-multipoint (RS-422) networks, the main cable should be terminated in its characteristic impedance (typically 120 $\Omega$ ) at the end farthest from the driver. In multi-receiver applications, stubs connecting receivers to the main cable should be kept as short as possible, but definitely shorter than the limits shown in Table 4. Multipoint (RS-485) systems require that the main cable be terminated in its characteristic impedance at both ends. Again, keep stubs connecting a transceiver to the main cable as short as possible, and refer to Table 4. Avoid "star", and other configurations, where there are many "ends" which would require more than the two allowed terminations to prevent reflections.

### High ESD

All pins on the ISL333X include ESD protection structures rated at  $\pm 2.5$ kV (HBM), which is good enough to survive ESD events commonly seen during manufacturing. But the bus pins (Tx outputs and Rx inputs) are particularly vulnerable to ESD events because they connect to an exposed port on the exterior of the finished product. Simply touching the port pins, or connecting a cable, can destroy an unprotected port. ISL333X bus pins are fitted with advanced structures that deliver ESD protection in excess of  $\pm 15$ kV (HBM), without interfering with any signal in the RS-485 or the RS-232 range. This high level of protection may eliminate the need for board level protection, or at the very least will increase the robustness of any board level scheme.

### Small Packages

Competing 3.3V dual protocol ICs are available only in a 28 Ld SSOP. The ISL3333's tiny 6x6mm QFN footprint is 80% smaller than the competing SSOP.

### Flow Through Pinouts

Even the ISL333X pinouts are features, in that the **true** flow-through design simplifies board layout. Having the bus pins all on one side of the package for easy routing to a cable connector, and the Rx outputs and Tx inputs (logic pins) on the other side for easy connection to a UART, avoids costly and problematic crossovers. Competing "flow through" pinouts mix logic and bus pin inputs on one side of the package, and logic and bus pin outputs on the other side. This forces the designer to route four traces from the right side of the IC around the IC to the cable connector. Figure 11 illustrates the flow-through nature of the ISL333X's pinout.

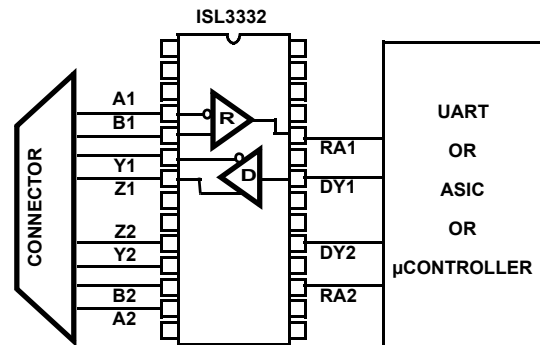

FIGURE 11. ILLUSTRATION OF FLOW THROUGH PINOUT

### Low Power Shutdown (SHDN) Mode

The ON/OFF pin is driven low to place the IC (both ports) in the SHDN mode, and the already low supply current drops to as low as 21 $\mu$ A. If this functionality isn't desired, the pin can be left disconnected (thanks to the internal pull-up), or it should be connected to  $V_{CC}$  ( $V_L$  for the QFN), through a 1k $\Omega$  resistor. SHDN disables the Tx and Rx outputs, and disables the charge pumps if either port is in RS-232 mode, so  $V+$  collapses to  $V_{CC}$ , and  $V-$  collapses to GND.

All but 10uA of SHDN supply current ( $I_{CC}$  plus  $I_L$ ) is due to control input (ON,  $\overline{LB}$ , SP, DE, DEN) pull-up resistors ( $\sim 11\mu A/resistor$ ), so SHDN supply current varies depending on the ISL333X configuration. The spec tables indicate the SHDN currents for configurations that optimize these currents. For example, in RS-232 mode the SP pins aren't used, so if both ports are configured for RS-232, floating or tying the SP pins high minimizes SHDN current. Likewise in RS-485 mode, the drivers are disabled in SHDN, so driving the DE and DEN pins high during this time also reduces the supply current.

When enabling from SHDN in RS-232 mode, allow at least 25μs for the charge pumps to stabilize before transmitting data. The charge pumps aren't used in RS-485 mode, so the transceiver is ready to send or receive data in less than 2μs, which is much faster than competing devices that require the charge pump for all modes of operation.

**Internal Loopback Mode**

Driving the  $\overline{LB}$  pin low places both ports in the loopback mode, a mode that facilitates implementing board level self test functions. In loopback, internal switches disconnect the Rx inputs from the Rx outputs, and feed back the Tx outputs to the appropriate Rx output. This way the data driven at the Tx input appears at the corresponding Rx output (refer to "Typical Operating Circuits" on page 6). The Tx outputs remain connected to their terminals, so the external loads are reflected in the loopback performance. This allows the loopback function to potentially detect some common bus faults such as one or both driver outputs shorted to GND, or outputs shorted together.

Note that the loopback mode uses an additional set of receivers, as shown in the "Typical Operating Circuits". These loopback receivers are not standards compliant, so the loopback mode can't be used to implement a half-duplex RS-485 transceiver.

If loopback won't be utilized, the pin can be left disconnected (thanks to the internal pull-up), or it should be connected to  $V_{CC}$  ( $V_L$  for the QFN), through a 1kΩ resistor.

**ISL3333 (QFN Package) Special Features**

**Logic Supply ( $V_L$  Pin)**

The ISL3333 (QFN) includes a  $V_L$  pin that powers the logic inputs (Tx inputs and control pins) and Rx outputs. These pins interface with "logic" devices such as UARTs, ASICs, and μcontrollers, and today most of these devices use power supplies significantly lower than 3.3V. Thus, a 3.3V output level from a 3.3V powered dual protocol IC might seriously overdrive and damage the logic device input. Similarly, the logic device's low  $V_{OH}$  might not exceed the  $V_{IH}$  of a 3.3V powered dual protocol input. Connecting the  $V_L$  pin to the power supply of the logic device (Figure 12) limits the ISL3333's Rx output  $V_{OH}$  to  $V_L$  (Figure 15), and reduces the Tx and control input switching points to values compatible

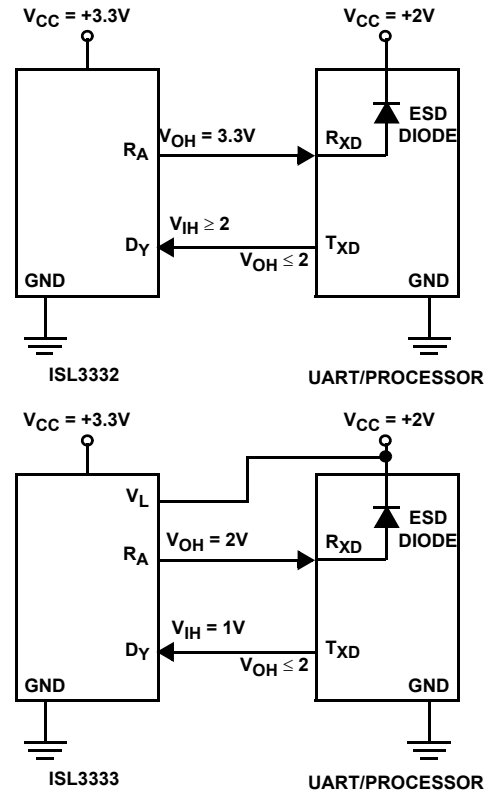

FIGURE 12. USING  $V_L$  PIN TO ADJUST LOGIC LEVELS

with the logic device output levels. Tailoring the logic pin input switching points and output levels to the supply voltage of the UART, ASIC, or μcontroller eliminates the need for a level shifter/translator between the two ICs.

$V_L$  can be anywhere from  $V_{CC}$  down to 1.2V, but the input switching points may not provide enough noise margin when  $V_L < 1.5V$ . Table 5 indicates typical  $V_{IH}$  and  $V_{IL}$  values for various  $V_L$  voltages so the user can ascertain whether or not a particular  $V_L$  voltage meets his needs.

TABLE 5.  $V_{IH}$  AND  $V_{IL}$  vs.  $V_L$  FOR  $V_{CC} = 3.3V$

| $V_L$ (V) | $V_{IH}$ (V) | $V_{IL}$ (V) |
|-----------|--------------|--------------|
| 1.2       | 0.85         | 0.26         |
| 1.5       | 0.9          | 0.5          |
| 1.8       | 0.9          | 0.73         |
| 2.3       | 1.2          | 1.0          |
| 2.7       | 1.4          | 1.3          |
| 3.3       | 1.8          | 1.7          |

Note: With  $V_L \leq 1.6V$ , the ISL3333 may not operate at the full data rate unless the logic signal  $V_{IL}$  is at least 0.2V below the typical value listed in Table 5.

The  $V_L$  supply current ( $I_L$ ) is typically less than 80μA, even in the worst case configuration, as shown in Figures 20 and 21. With the Rx outputs unloaded, all of the DC  $V_L$  current is due to inputs with internal pull-up resistors (DE, DEN, SP,  $\overline{LB}$ ,

ON/OFF) being driven to the low input state. The worst case  $I_L$  current occurs during SHDN (see Figure 21), due to the  $I_L$  through the ON/OFF pin pull-up resistor when that pin is driven low.  $I_L$  through an input pull-up resistor is  $\sim 11\mu\text{A}$  ( $6\mu\text{A}$  for DE1 and DE2), so the  $I_L$  in Figure 20 drops by about  $22\mu\text{A}$  (at  $V_L = 3.3\text{V}$ ) when the two SP inputs are high versus low (next to bottom vs. top curve). SHDN  $I_L$  is lowest in the RS-232 mode, because only the DEN pins and/or the ON/OFF pin should be driven low. When all the inputs with pull-downs are driven high,  $I_L$  drops to  $\ll 1\mu\text{A}$  (see Figure 20), so to minimize power dissipation drive these inputs high when unneeded (e.g., SP inputs aren't used in RS-232 mode, and DEN inputs aren't used in RS-485 mode, so drive them high in those modes).

QFN logic input pins that are externally tied high in an application, should use the  $V_L$  supply for the high voltage level.

### RS-232 Mode Tx Enable/Disable (DEN)

The ISL3333 also adds an RS-232 mode Tx enable pin (DENX) for each port. Driving one of these pins low disables both drivers in the corresponding port. Because RS-232 is a point-to-point (only one Tx allowed on the bus) standard, the main use for this disable function is to reduce power by eliminating the load current (approximately  $1\text{mA}$  per Tx output) through the  $5\text{k}\Omega$  resistor in the Rx at the cable's far end. The  $I_{CC}$  in this mode is still considerably higher than in SHDN, but the enable time from Tx disable is much faster ( $1.5\mu\text{s}$  vs.  $25\mu\text{s}$ ) than the enable time from SHDN due to the charge pumps remaining on during Tx disable.

The DENX pin is ignored if the corresponding port is set for RS-485 mode, and it is internally pulled high.

### Active Low Rx Enable (RXEN)

In many RS-485 applications, especially half duplex configurations, users like to accomplish "echo cancellation" by disabling the corresponding receiver while its driver is transmitting data. This function is available on the QFN package via an active low  $\overline{\text{RXEN}}$  pin for each port. The active low function also simplifies direction control, by allowing a single Tx/Rx direction control line. If an active high RXEN were used, either two valuable I/O pins would be used for direction control, or an external inverter is required between DE and RXEN. Figure 13 details the advantage of using the  $\overline{\text{RXEN}}$  pin.

### RS-485 Slew Rate Limited Data Rates

The SSOP version of this IC operates with Tx output transitions optimized for a  $20\text{Mbps}$  data rate. These fast edges may increase EMI and reflection issues, even though fast transitions aren't required at the lower data rates used by many applications. The ISL3333 (QFN version) solves this problem by offering two additional, slew rate limited, data rates that are optimized for speeds of  $115\text{kbps}$ , and  $460\text{kbps}$ . The slew limited edges permit longer unterminated networks, or longer stubs off terminated busses, and help

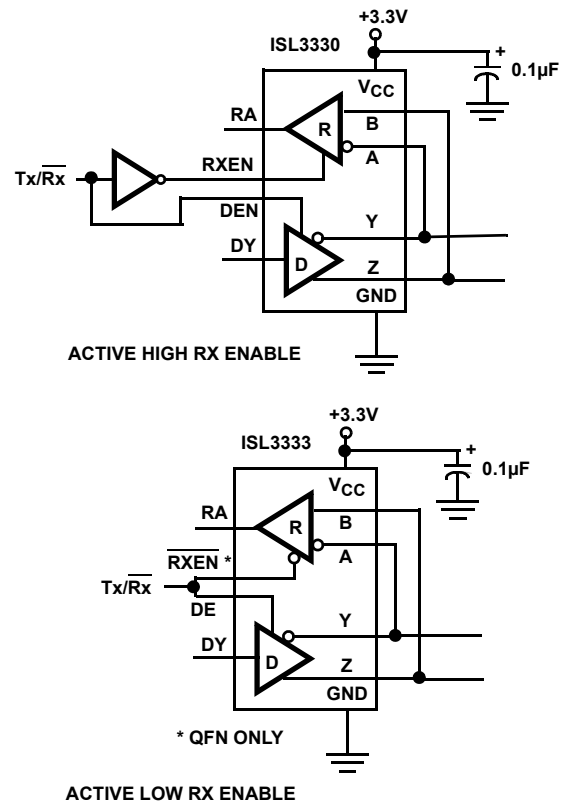

FIGURE 13. USING ACTIVE LOW vs ACTIVE HIGH RX ENABLE

minimize EMI and reflections. Nevertheless, for the best jitter performance when driving long cables, the faster speed options may be preferable, even at lower data rates. The faster output transitions deliver less variability (jitter) when loaded with the large capacitance associated with long cables. Of course, faster transitions require more attention to ensuring short stub lengths and quality terminations, so there are trade-offs to be made. Assuming a jitter budget of 10%, it is likely better to go with the slow speed option for data rates of  $115\text{kbps}$  or less, to minimize fast edge effects. Likewise, the medium speed option is a good choice for data rates between  $115\text{kbps}$  and  $460\text{kbps}$ . For higher data rates, or when the absolute best jitter is required, use the high speed option. Speed selection is via the SPA and SPB pins (see Table 3), and the selection pertains to each port programmed for RS-485 mode.

### Evaluation Board

An evaluation board, part number ISL3333EVAL1Z, is available to assist in assessing the dual protocol IC's performance. The evaluation board contains a QFN packaged device, but because the same die is used in all packages, the board is also useful for evaluating the functionality of the other versions. The board's design allows for evaluation of all standard features, plus the QFN specific features. Refer to the eval board application note for details, and contact your sales rep for ordering information.

**Typical Performance Curves**  $V_{CC} = V_L = 3.3V$ ,  $T_A = +25^\circ C$ ; Unless Otherwise Specified

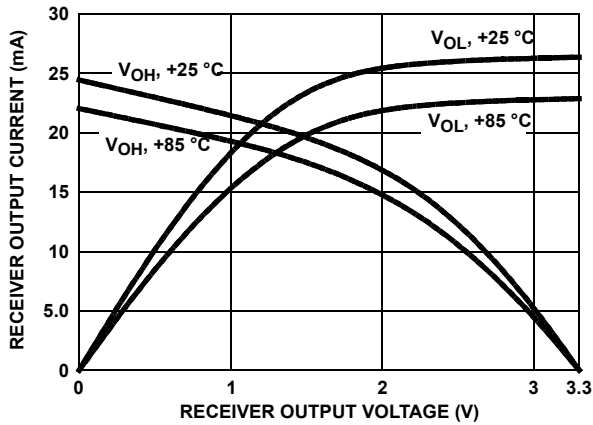

FIGURE 14. RECEIVER OUTPUT CURRENT vs RECEIVER OUTPUT VOLTAGE

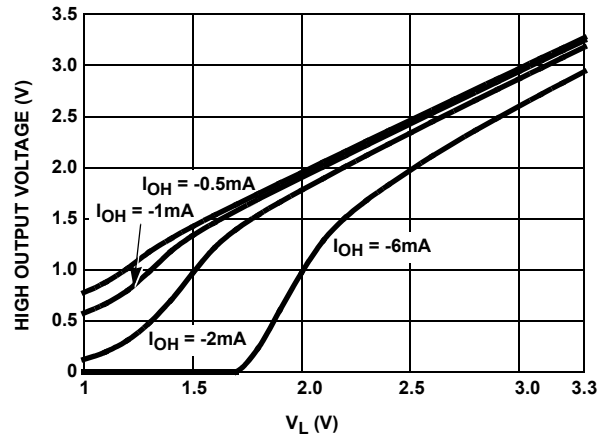

FIGURE 15. RECEIVER HIGH OUTPUT VOLTAGE vs LOGIC SUPPLY VOLTAGE ( $V_L$ ) (QFN ONLY)

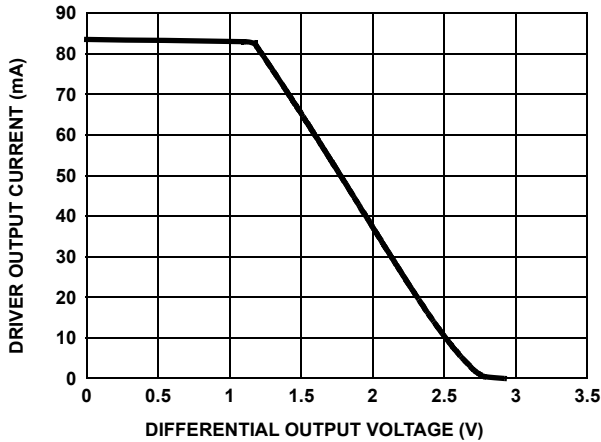

FIGURE 16. RS-485, DRIVER OUTPUT CURRENT vs DIFFERENTIAL OUTPUT VOLTAGE

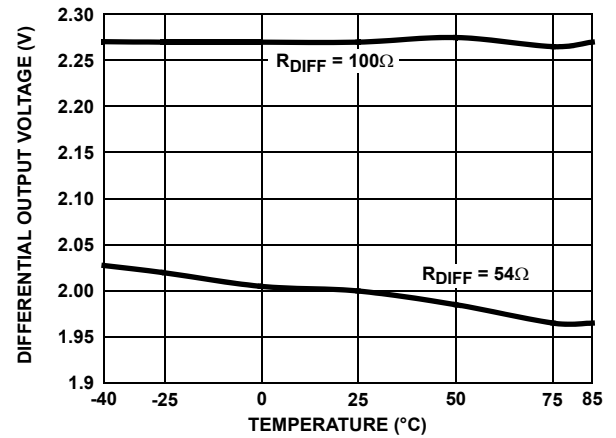

FIGURE 17. RS-485, DRIVER DIFFERENTIAL OUTPUT VOLTAGE vs TEMPERATURE

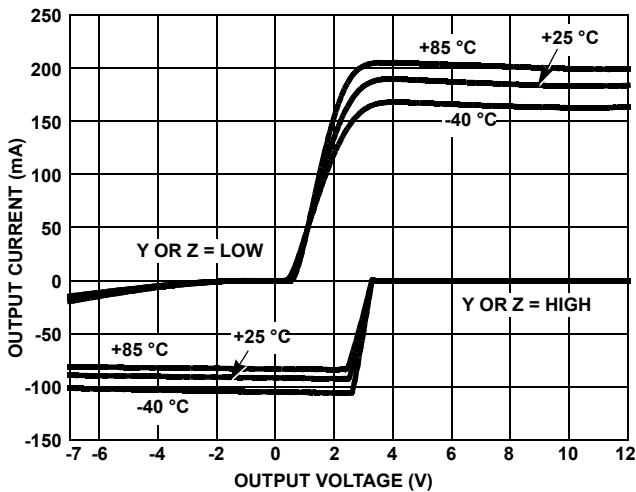

FIGURE 18. RS-485, DRIVER OUTPUT CURRENT vs SHORT CIRCUIT VOLTAGE

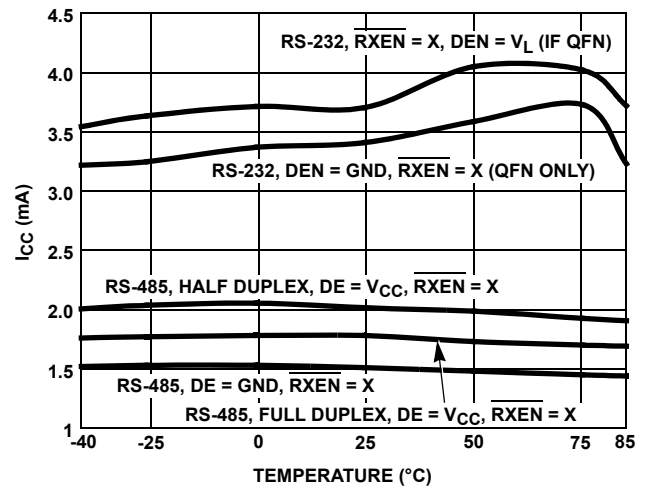

FIGURE 19. SUPPLY CURRENT vs TEMPERATURE

**Typical Performance Curves**  $V_{CC} = V_L = 3.3V$ ,  $T_A = +25^\circ C$ ; Unless Otherwise Specified (Continued)

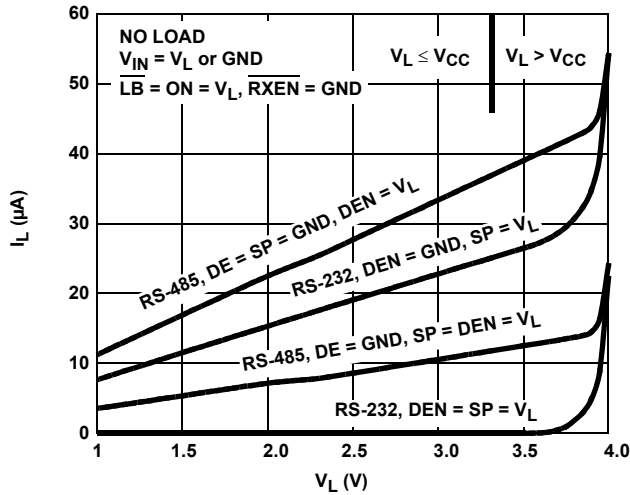

FIGURE 20.  $V_L$  SUPPLY CURRENT vs  $V_L$  VOLTAGE (QFN ONLY)

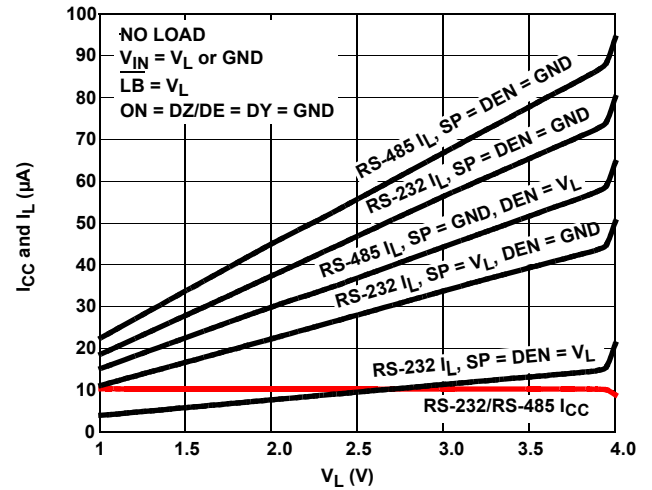

FIGURE 21.  $V_{CC}$  and  $V_L$  SHDN SUPPLY CURRENTS vs  $V_L$  VOLTAGE (QFN ONLY)

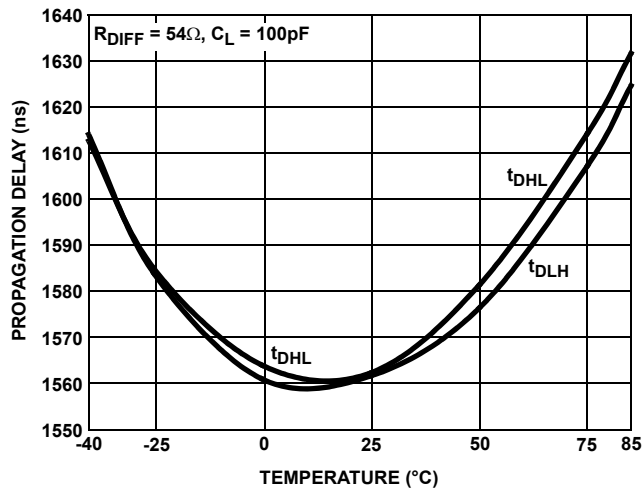

FIGURE 22. RS-485, DRIVER PROPAGATION DELAY vs TEMPERATURE (SLOW DATA RATE, QFN ONLY)

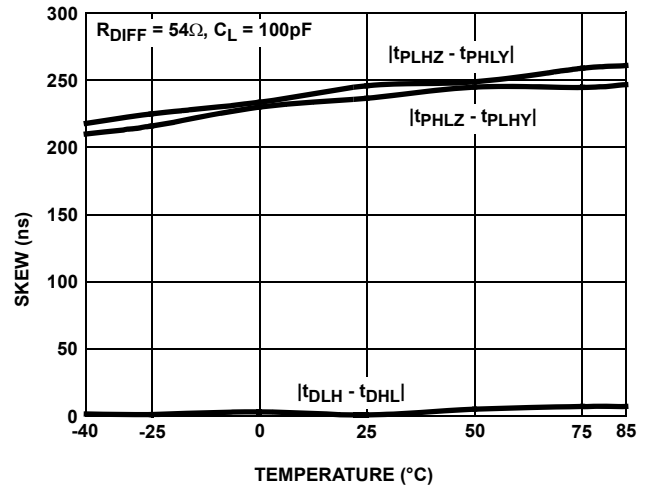

FIGURE 23. RS-485, DRIVER SKEW vs TEMPERATURE (SLOW DATA RATE, QFN ONLY)

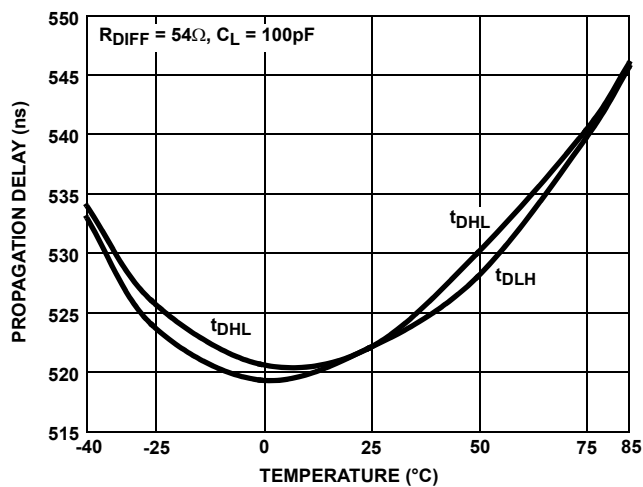

FIGURE 24. RS-485, DRIVER PROPAGATION DELAY vs TEMPERATURE (MEDIUM DATA RATE, QFN ONLY)

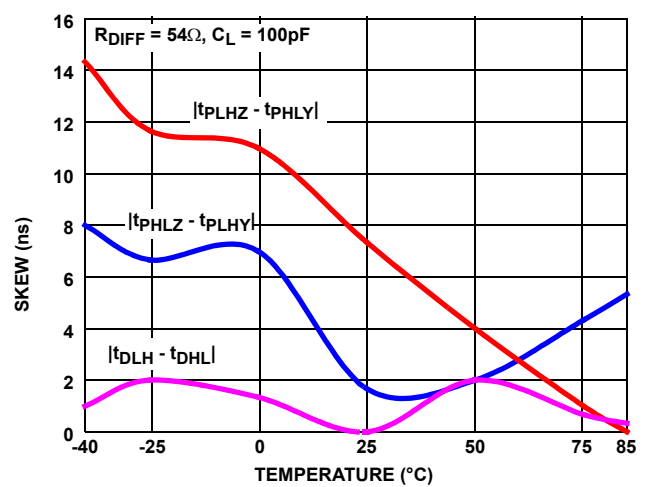

FIGURE 25. RS-485, DRIVER SKEW vs TEMPERATURE (MEDIUM DATA RATE, QFN ONLY)

**Typical Performance Curves**  $V_{CC} = V_L = 3.3V$ ,  $T_A = +25^\circ C$ ; Unless Otherwise Specified (Continued)

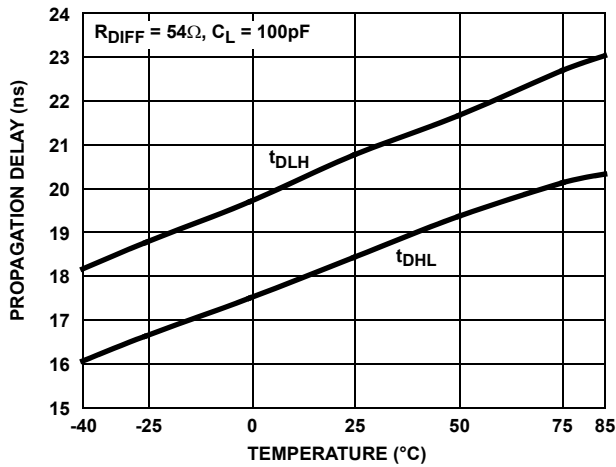

FIGURE 26. RS-485, DRIVER PROPAGATION DELAY vs TEMPERATURE (FAST DATA RATE)

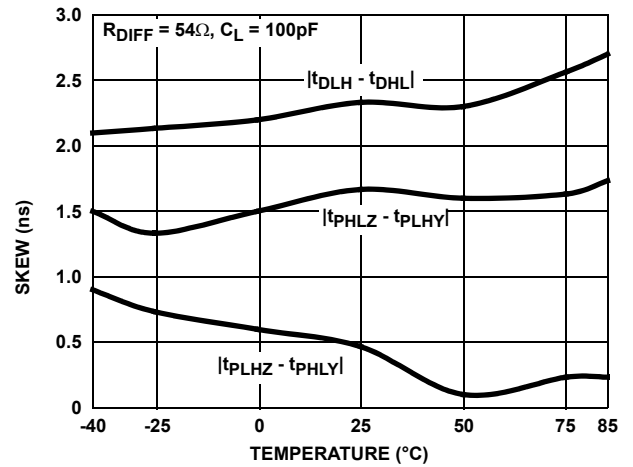

FIGURE 27. RS-485, DRIVER SKEW vs TEMPERATURE (FAST DATA RATE)

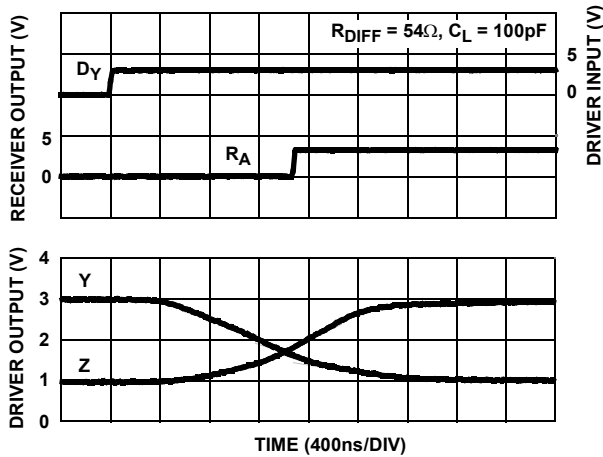

FIGURE 28. RS-485, DRIVER AND RECEIVER WAVEFORMS, LOW TO HIGH (SLOW DATA RATE, QFN ONLY)

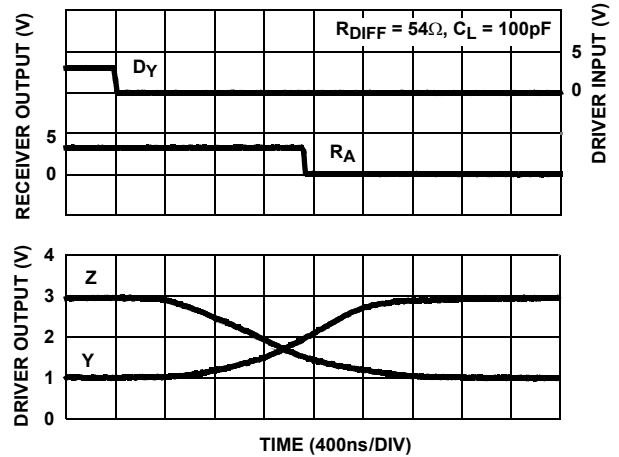

FIGURE 29. RS-485, DRIVER AND RECEIVER WAVEFORMS, HIGH TO LOW (SLOW DATA RATE, QFN ONLY)

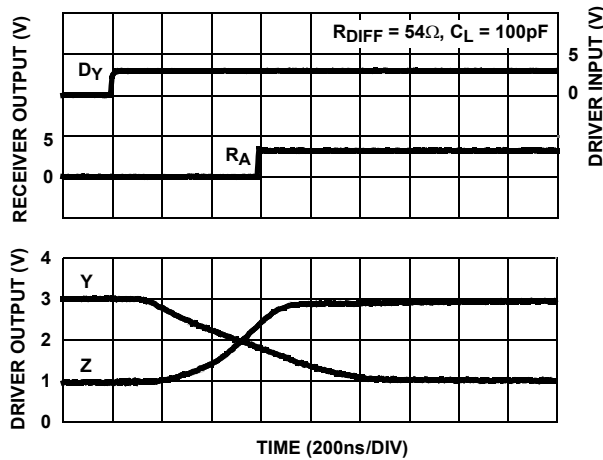

FIGURE 30. RS-485, DRIVER AND RECEIVER WAVEFORMS, LOW TO HIGH (MEDIUM DATA RATE, QFN ONLY)

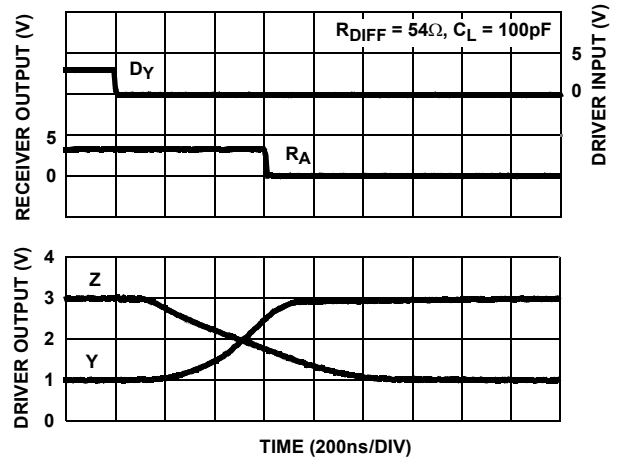

FIGURE 31. RS-485, DRIVER AND RECEIVER WAVEFORMS, HIGH TO LOW (MEDIUM DATA RATE, QFN ONLY)

**Typical Performance Curves**  $V_{CC} = V_L = 3.3V$ ,  $T_A = +25^\circ C$ ; Unless Otherwise Specified (Continued)

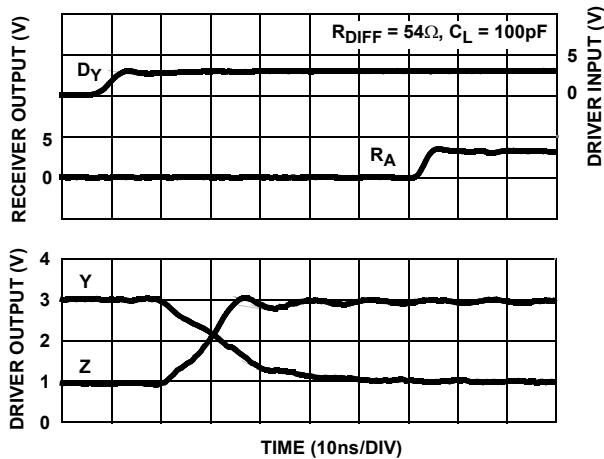

FIGURE 32. RS-485, DRIVER AND RECEIVER WAVEFORMS, LOW TO HIGH (FAST DATA RATE)

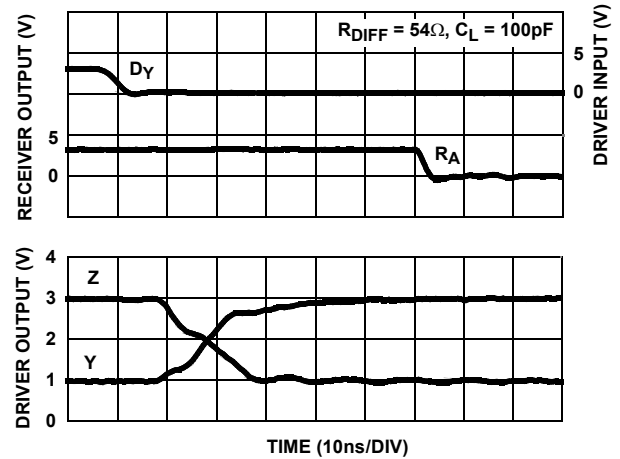

FIGURE 33. RS-485, DRIVER AND RECEIVER WAVEFORMS, HIGH TO LOW (FAST DATA RATE)

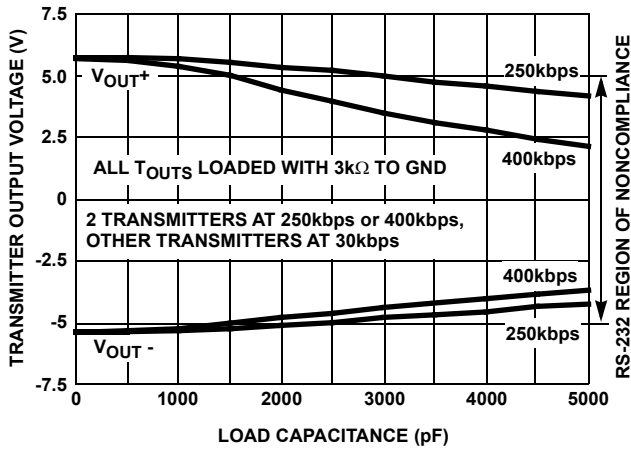

FIGURE 34. RS-232, TRANSMITTER OUTPUT VOLTAGE vs LOAD CAPACITANCE

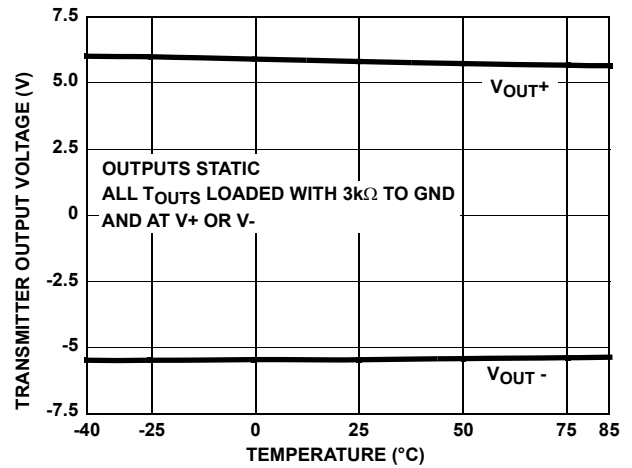

FIGURE 35. RS-232, TRANSMITTER OUTPUT VOLTAGE vs TEMPERATURE

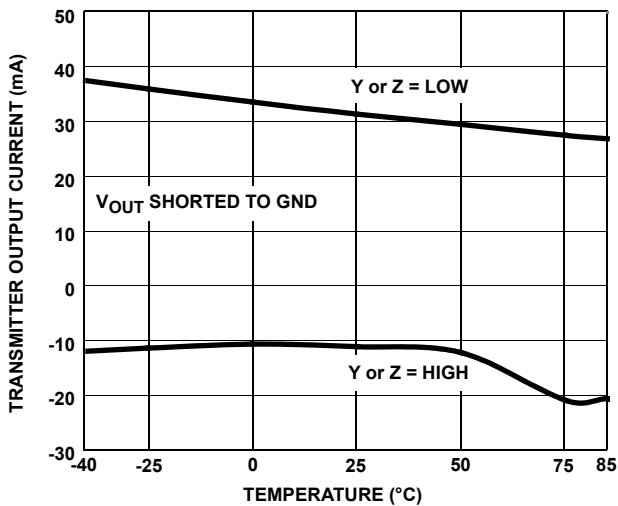

FIGURE 36. RS-232, TRANSMITTER SHORT CIRCUIT CURRENT vs TEMPERATURE

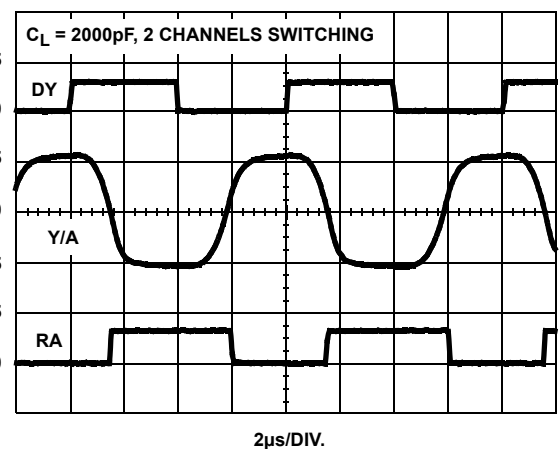

FIGURE 37. RS-232, TRANSMITTER AND RECEIVER WAVEFORMS AT 250kbps

**Typical Performance Curves**  $V_{CC} = V_L = 3.3V$ ,  $T_A = +25^\circ C$ ; Unless Otherwise Specified (Continued)

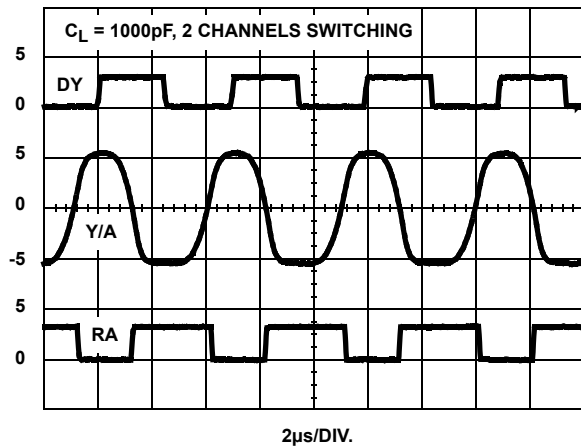

FIGURE 38. RS-232, TRANSMITTER AND RECEIVER WAVEFORMS AT 400kbps

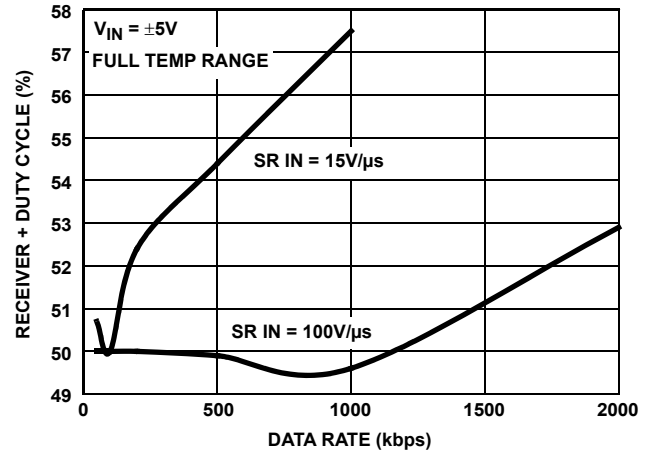

FIGURE 39. RS-232, RECEIVER OUTPUT + DUTY CYCLE vs DATA RATE

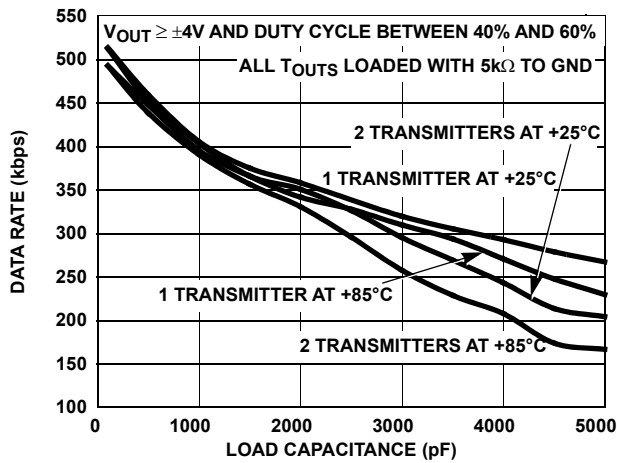

FIGURE 40. RS-232, TRANSMITTER MAXIMUM DATA RATE vs LOAD CAPACITANCE

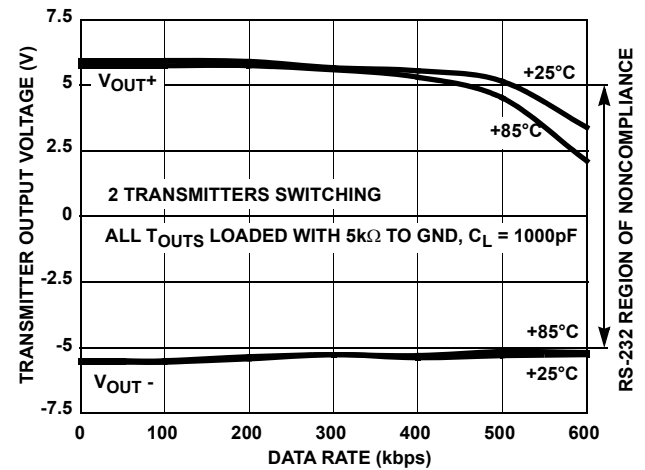

FIGURE 41. RS-232, TRANSMITTER OUTPUT VOLTAGE vs DATA RATE

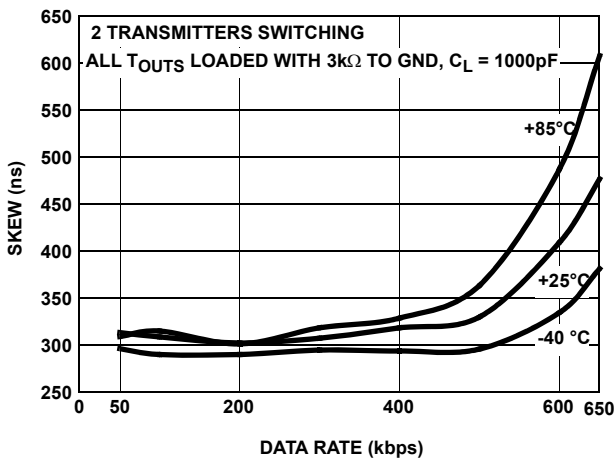

FIGURE 42. RS-232, TRANSMITTER SKEW vs DATA RATE

**Die Characteristics**

**SUBSTRATE AND QFN PAD POTENTIAL (POWERED UP):**

GND

**TRANSISTOR COUNT:**

4838

**PROCESS:**

BiCMOS



---

**Revision History**

| <b>Rev.</b> | <b>Date</b>  | <b>Description</b>   |
|-------------|--------------|--|
| 1.0         | Jan 21, 2021 | Updated Ordering information table and notes.<br>Updated links throughout.<br>Added Revision History |
| 0.0         | May 27, 2008 | Initial release  |

**Package Outline Drawings**

For the most recent package outline drawing, see [L40.6x6](#).

L40.6x6  
 40 Lead Quad Flat No-Lead Plastic Package  
 Rev 3, 10/06

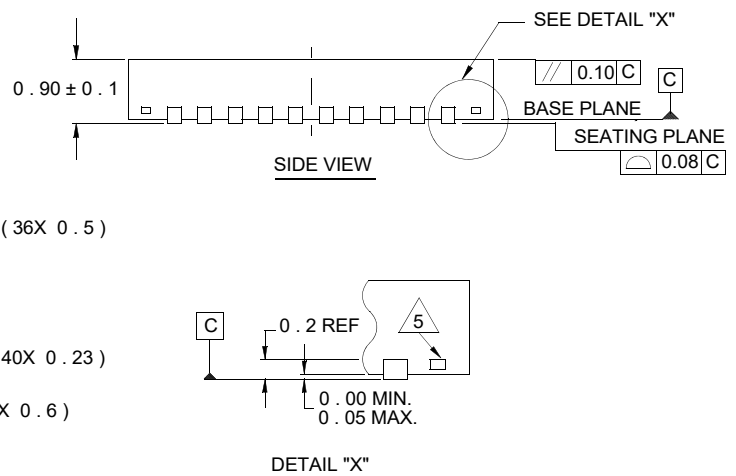
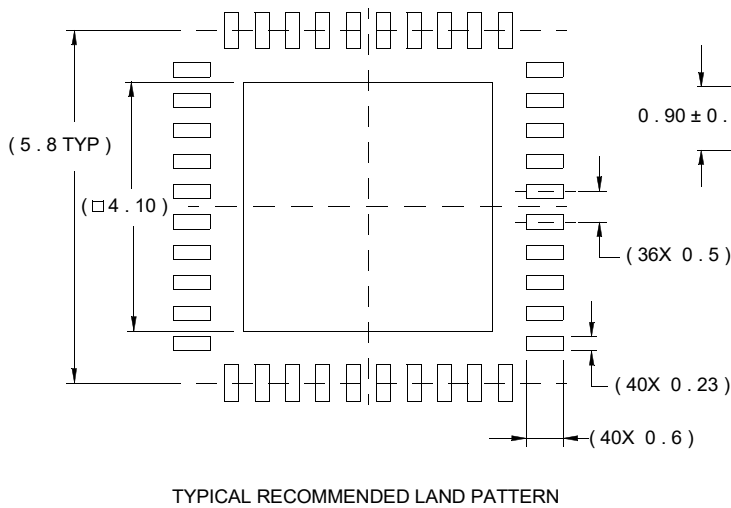
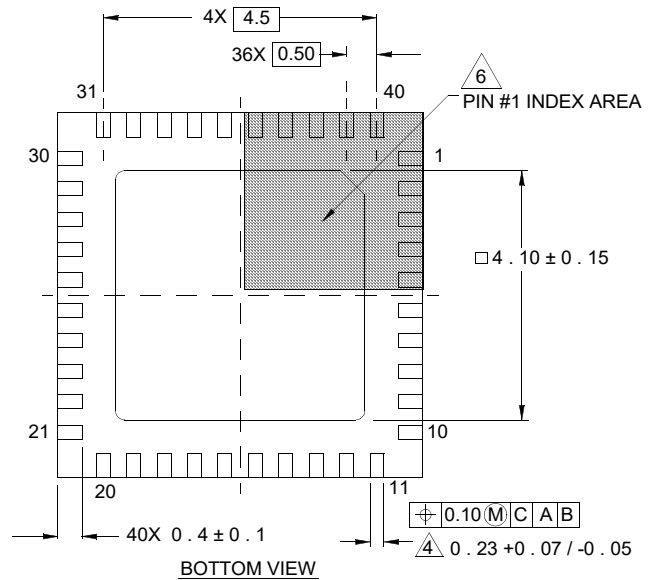
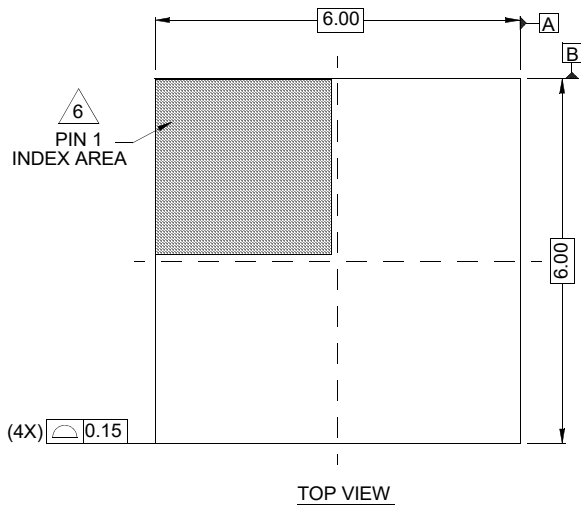

**NOTES:**

1. Dimensions are in millimeters.  
 Dimensions in ( ) for Reference Only.
2. Dimensioning and tolerancing conform to AMSE Y14.5m-1994.
3. Unless otherwise specified, tolerance : Decimal ± 0.05
4. Dimension b applies to the metallized terminal and is measured between 0.15mm and 0.30mm from the terminal tip.
5. Tiebar shown (if present) is a non-functional feature.
6. The configuration of the pin #1 identifier is optional, but must be located within the zone indicated. The pin #1 identifier may be either a mold or mark feature.

**Shrink Small Outline Plastic Packages (SSOP)**

For the most recent package outline drawing, see [M28.209](#).

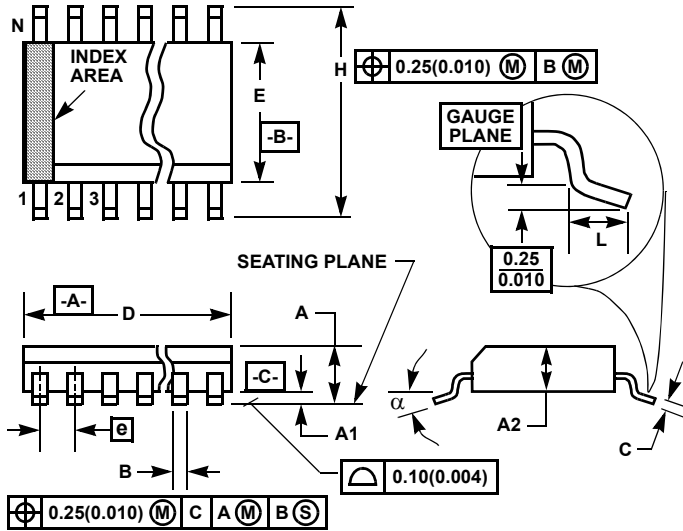

M28.209 (JEDEC MO-150-AH ISSUE B)  
28 Lead Shrink Small Outline Plastic Package

| SYMBOL   | INCHES    |       | MILLIMETERS |       | NOTES |
|----------|-----------|-------|-------------|-------|-------|
|          | MIN       | MAX   | MIN         | MAX   |       |
| A        | -         | 0.078 | -           | 2.00  | -     |
| A1       | 0.002     | -     | 0.05        | -     | -     |
| A2       | 0.065     | 0.072 | 1.65        | 1.85  | -     |
| B        | 0.009     | 0.014 | 0.22        | 0.38  | 9     |
| C        | 0.004     | 0.009 | 0.09        | 0.25  | -     |
| D        | 0.390     | 0.413 | 9.90        | 10.50 | 3     |
| E        | 0.197     | 0.220 | 5.00        | 5.60  | 4     |
| e        | 0.026 BSC |       | 0.65 BSC    |       | -     |
| H        | 0.292     | 0.322 | 7.40        | 8.20  | -     |
| L        | 0.022     | 0.037 | 0.55        | 0.95  | 6     |
| N        | 28        |       | 28          |       | 7     |
| $\alpha$ | 0°        | 8°    | 0°          | 8°    | -     |

**NOTES:**

1. Symbols are defined in the "MO Series Symbol List" in Section 2.2 of Publication Number 95.
2. Dimensioning and tolerancing per ANSI Y14.5M-1982.
3. Dimension "D" does not include mold flash, protrusions or gate burrs. Mold flash, protrusion and gate burrs shall not exceed 0.20mm (0.0078 inch) per side.
4. Dimension "E" does not include interlead flash or protrusions. Interlead flash and protrusions shall not exceed 0.20mm (0.0078 inch) per side.
5. The chamfer on the body is optional. If it is not present, a visual index feature must be located within the crosshatched area.
6. "L" is the length of terminal for soldering to a substrate.
7. "N" is the number of terminal positions.
8. Terminal numbers are shown for reference only.
9. Dimension "B" does not include dambar protrusion. Allowable dambar protrusion shall be 0.13mm (0.005 inch) total in excess of "B" dimension at maximum material condition.
10. Controlling dimension: MILLIMETER. Converted inch dimensions are not necessarily exact.

Rev. 2 6/05

## IMPORTANT NOTICE AND DISCLAIMER

RENESAS ELECTRONICS CORPORATION AND ITS SUBSIDIARIES (“RENESAS”) PROVIDES TECHNICAL SPECIFICATIONS AND RELIABILITY DATA (INCLUDING DATASHEETS), DESIGN RESOURCES (INCLUDING REFERENCE DESIGNS), APPLICATION OR OTHER DESIGN ADVICE, WEB TOOLS, SAFETY INFORMATION, AND OTHER RESOURCES “AS IS” AND WITH ALL FAULTS, AND DISCLAIMS ALL WARRANTIES, EXPRESS OR IMPLIED, INCLUDING, WITHOUT LIMITATION, ANY IMPLIED WARRANTIES OF MERCHANTABILITY, FITNESS FOR A PARTICULAR PURPOSE, OR NON-INFRINGEMENT OF THIRD PARTY INTELLECTUAL PROPERTY RIGHTS.

These resources are intended for developers skilled in the art designing with Renesas products. You are solely responsible for (1) selecting the appropriate products for your application, (2) designing, validating, and testing your application, and (3) ensuring your application meets applicable standards, and any other safety, security, or other requirements. These resources are subject to change without notice. Renesas grants you permission to use these resources only for development of an application that uses Renesas products. Other reproduction or use of these resources is strictly prohibited. No license is granted to any other Renesas intellectual property or to any third party intellectual property. Renesas disclaims responsibility for, and you will fully indemnify Renesas and its representatives against, any claims, damages, costs, losses, or liabilities arising out of your use of these resources. Renesas' products are provided only subject to Renesas' Terms and Conditions of Sale or other applicable terms agreed to in writing. No use of any Renesas resources expands or otherwise alters any applicable warranties or warranty disclaimers for these products.

(Rev.1.0 Mar 2020)

### Corporate Headquarters

TOYOSU FORESIA, 3-2-24 Toyosu,  
Koto-ku, Tokyo 135-0061, Japan  
[www.renesas.com](http://www.renesas.com)

### Contact Information

For further information on a product, technology, the most up-to-date version of a document, or your nearest sales office, please visit:  
[www.renesas.com/contact/](http://www.renesas.com/contact/)

### Trademarks

Renesas and the Renesas logo are trademarks of Renesas Electronics Corporation. All trademarks and registered trademarks are the property of their respective owners.